



KM-1505

SERVICE MANUAL

Published in Mar.'01
842BT110

CAUTION

Danger of explosion if battery is incorrectly replaced. Replace only with the same or equivalent type recommended by the manufacturer. Dispose of used batteries according to the manufacturer's instructions.

CAUTION

Double-pole/neutral fusing.





Safety precautions

This booklet provides safety warnings and precautions for our service personnel to ensure the safety of their customers, their machines as well as themselves during maintenance activities. Service personnel are advised to read this booklet carefully to familiarize themselves with the warnings and precautions described here before engaging in maintenance activities.

Safety warnings and precautions

Various symbols are used to protect our service personnel and customers from physical danger and to prevent damage to their property. These symbols are described below:

 **DANGER:** High risk of serious bodily injury or death may result from insufficient attention to or incorrect compliance with warning messages using this symbol.

 **WARNING:** Serious bodily injury or death may result from insufficient attention to or incorrect compliance with warning messages using this symbol.

 **CAUTION:** Bodily injury or damage to property may result from insufficient attention to or incorrect compliance with warning messages using this symbol.

Symbols

The triangle (\triangle) symbol indicates a warning including danger and caution. The specific point of attention is shown inside the symbol.



General warning.



Warning of risk of electric shock.



Warning of high temperature.

 indicates a prohibited action. The specific prohibition is shown inside the symbol.



General prohibited action.



Disassembly prohibited.

 indicates that action is required. The specific action required is shown inside the symbol.



General action required.



Remove the power plug from the wall outlet.



Always ground the copier.

1. Installation Precautions

WARNING

• Do not use a power supply with a voltage other than that specified. Avoid multiple connections to one outlet: they may cause fire or electric shock. When using an extension cable, always check that it is adequate for the rated current.



• Connect the ground wire to a suitable grounding point. Not grounding the copier may cause fire or electric shock. Connecting the earth wire to an object not approved for the purpose may cause explosion or electric shock. Never connect the ground cable to any of the following: gas pipes, lightning rods, ground cables for telephone lines and water pipes or faucets not approved by the proper authorities.



CAUTION:

• Do not place the copier on an infirm or angled surface: the copier may tip over, causing injury.



• Do not install the copier in a humid or dusty place. This may cause fire or electric shock.



• Do not install the copier near a radiator, heater, other heat source or near flammable material. This may cause fire.



• Allow sufficient space around the copier to allow the ventilation grills to keep the machine as cool as possible. Insufficient ventilation may cause heat buildup and poor copying performance.



• Always handle the machine by the correct locations when moving it.



• Always use anti-toppling and locking devices on copiers so equipped. Failure to do this may cause the copier to move unexpectedly or topple, leading to injury.



• Avoid inhaling toner or developer excessively. Protect the eyes. If toner or developer is accidentally ingested, drink a lot of water to dilute it in the stomach and obtain medical attention immediately. If it gets into the eyes, rinse immediately with copious amounts of water and obtain medical attention.













• Advise customers that they must always follow the safety warnings and precautions in the copier's instruction handbook.

















2. Precautions for Maintenance

WARNING

- Always remove the power plug from the wall outlet before starting machine disassembly. 
- Always follow the procedures for maintenance described in the service manual and other related brochures. 
- Under no circumstances attempt to bypass or disable safety features including safety mechanisms and protective circuits. 
- Always use parts having the correct specifications. 
- Always use the thermostat or thermal fuse specified in the service manual or other related brochure when replacing them. Using a piece of wire, for example, could lead to fire or other serious accident. 
- When the service manual or other serious brochure specifies a distance or gap for installation of a part, always use the correct scale and measure carefully. 
- Always check that the copier is correctly connected to an outlet with a ground connection. 
- Check that the power cable covering is free of damage. Check that the power plug is dust-free. If it is dirty, clean it to remove the risk of fire or electric shock. 
- Never attempt to disassemble the optical unit in machines using lasers. Leaking laser light may damage eyesight. 
- Handle the charger sections with care. They are charged to high potentials and may cause electric shock if handled improperly. 

CAUTION

- Wear safe clothing. If wearing loose clothing or accessories such as ties, make sure they are safely secured so they will not be caught in rotating sections. 
- Use utmost caution when working on a powered machine. Keep away from chains and belts. 
- Handle the fixing section with care to avoid burns as it can be extremely hot. 
- Check that the fixing unit thermistor, heat and press rollers are clean. Dirt on them can cause abnormally high temperatures. 
- Do not remove the ozone filter, if any, from the copier except for routine replacement. 

- Do not pull on the AC power cord or connector wires on high-voltage components when removing them; always hold the plug itself. 
- Do not route the power cable where it may be stood on or trapped. If necessary, protect it with a cable cover or other appropriate item. 
- Treat the ends of the wire carefully when installing a new charger wire to avoid electric leaks. 
- Remove toner completely from electronic components. 
- Run wire harnesses carefully so that wires will not be trapped or damaged. 
- After maintenance, always check that all the parts, screws, connectors and wires that were removed, have been refitted correctly. Special attention should be paid to any forgotten connector, trapped wire and missing screws. 
- Check that all the caution labels that should be present on the machine according to the instruction handbook are clean and not peeling. Replace with new ones if necessary. 
- Handle greases and solvents with care by following the instructions below: 
 - Use only a small amount of solvent at a time, being careful not to spill. Wipe spills off completely.
 - Ventilate the room well while using grease or solvents.
 - Allow applied solvents to evaporate completely before refitting the covers or turning the main switch on.
 - Always wash hands afterwards.
- Never dispose of toner or toner bottles in fire. Toner may cause sparks when exposed directly to fire in a furnace, etc. 
- Should smoke be seen coming from the copier, remove the power plug from the wall outlet immediately. 

3. Miscellaneous

 **WARNING**

- Never attempt to heat the drum or expose it to any organic solvents such as alcohol, other than the specified refiner; it may generate toxic gas. 

CONTENTS

1-1 Specifications	
1-1-1 Specifications	1-1-1
1-1-2 Parts names	1-1-2
(1) Copier	1-1-2
(2) Operation panel	1-1-3
1-1-3 Machine cross section	1-1-4
1-1-4 Drive system	1-1-5
(1) Drive system 1 (drive motor drive train)	1-1-5
(2) Drive system 2 (scanner motor drive train)	1-1-6
1-2 Handling Precautions	
1-2-1 Drum	1-2-1
1-2-2 Developer and toner	1-2-1
1-2-3 Installation environment	1-2-2
1-3 Installation	
1-3-1 Unpacking and installation	1-3-1
(1) Installation procedure	1-3-1
1-3-2 Setting initial copy modes	1-3-10
1-3-3 Copier management	1-3-11
(1) Executing a copier management item	1-3-11
(2) Default settings	1-3-12
1-4 Maintenance Mode	
1-4-1 Maintenance mode	1-4-1
(1) Executing a maintenance item	1-4-1
(2) Maintenance mode item list	1-4-2
(3) Contents of maintenance mode items	1-4-4
1-5 Troubleshooting	
1-5-1 Paper misfeed detection	1-5-1
(1) Paper misfeed indication	1-5-1
(2) Paper misfeed detection conditions	1-5-2
(3) Paper misfeeds	1-5-5
1-5-2 Self-diagnosis	1-5-7
(1) Self-diagnostic function	1-5-7
(2) Self-diagnostic codes	1-5-7
1-5-3 Image formation problems	1-5-11
(1) No image appears (entirely white).	1-5-12
(2) No image appears (entirely black).	1-5-12
(3) Image is too light.	1-5-13
(4) Background is visible.	1-5-13
(5) A white line appears longitudinally.	1-5-13
(6) A black line appears longitudinally.	1-5-14
(7) A black line appears laterally.	1-5-14
(8) One side of the copy image is darker than the other.	1-5-14
(9) Black dots appear on the image.	1-5-15
(10) Image is blurred.	1-5-15
(11) The leading edge of the image is consistently misaligned with the original.	1-5-15
(12) The leading edge of the image is sporadically misaligned with the original.	1-5-16
(13) Paper creases.	1-5-16
(14) Offset occurs.	1-5-16
(15) Image is partly missing.	1-5-17
(16) Fixing is poor.	1-5-17
(17) Image is out of focus.	1-5-17

(18) Image center does not align with the original center.	1-5-18
(19) Image contrast is low (carrier scattering).	1-5-18
1-5-4 Electrical problems	1-5-19
(1) The machine does not operate when the main switch is turned on.	1-5-19
(2) The drive motor does not operate.	1-5-19
(3) The scanner motor does not operate.	1-5-19
(4) The toner feed motor does not operate.	1-5-19
(5) Cooling fan motor does not operate.	1-5-19
(6) The registration clutch does not operate.	1-5-19
(7) The paper feed clutch does not operate.	1-5-20
(8) The bypass paper feed clutch does not operate.	1-5-20
(9) The cleaning lamp does not turn on.	1-5-20
(10) The exposure lamp does not turn on.	1-5-20
(11) The exposure lamp does not turn off.	1-5-20
(12) The fixing heater does not turn on (C610).	1-5-20
(13) The fixing heater does not turn off.	1-5-20
(14) Main charging is not performed (C510).	1-5-20
(15) Transfer charging is not performed.	1-5-21
(16) No developing bias is output.	1-5-21
(17) A paper jam in the paper feed, paper conveying or fixing section is indicated when the main switch is turned on.	1-5-21
(18) The message requesting covers to be closed is displayed when the front cover and paper conveying cover are closed.	1-5-21
(19) Others.	1-5-21
1-5-5 Mechanical problems	1-5-22
(1) No primary paper feed.	1-5-22
(2) No secondary paper feed.	1-5-22
(3) Skewed paper feed.	1-5-22
(4) The scanner does not travel.	1-5-22
(5) Multiple sheets of paper are fed at one time.	1-5-22
(6) Paper jams.	1-5-22
(7) Toner drops on the paper conveying path.	1-5-22
(8) Abnormal noise is heard.	1-5-22
1-6 Assembly and Disassembly	
1-6-1 Precautions for assembly and disassembly	1-6-1
(1) Precautions	1-6-1
(2) Running a maintenance item	1-6-2
1-6-2 Paper feed section	1-6-3
(1) Detaching and refitting the paper feed pulleys	1-6-3
(2) Detaching and refitting the bypass paper feed pulley	1-6-5
(3) Adjustment after roller and clutch replacement	1-6-8
(3-1) Adjusting the leading edge registration of image printing	1-6-8
(3-2) Adjusting the center line of image printing	1-6-9
(3-3) Adjusting the margins for printing	1-6-10
(3-4) Adjusting the amount of slack in the paper	1-6-11
1-6-3 Optical section	1-6-12
(1) Detaching and refitting the exposure lamp	1-6-12
(2) Detaching and refitting the scanner wires	1-6-14
(2-1) Detaching the scanner wires	1-6-14
(2-2) Fitting the scanner wires	1-6-15
(3) Detaching and refitting the laser scanner unit	1-6-18
(4) Detaching and refitting the ISU (reference)	1-6-20
(5) Adjusting the longitudinal squareness (reference)	1-6-21
(6) Adjusting magnification of the scanner in the main scanning direction	1-6-22
(7) Adjusting magnification of the scanner in the auxiliary scanning direction	1-6-23
(8) Adjusting the scanner leading edge registration	1-6-24
(9) Adjusting the scanner center line	1-6-25
(10) Adjusting the margins for scanning an original on the contact glass	1-6-26

1-6-4	Image formation section	1-6-27
	(1) Detaching and refitting the image formation unit	1-6-27
	(2) Detaching and refitting the main charger unit	1-6-28
	(3) Detaching and refitting the drum	1-6-29
	(4) Detaching and refitting the cleaning blade	1-6-31
	(5) Replace the developer	1-6-32
1-6-5	Transfer section	1-6-33
	(1) Detaching and refitting the transfer roller assembly	1-6-33
1-6-6	Fixing section	1-6-34
	(1) Detaching and refitting the fixing unit	1-6-34
	(2) Detaching and refitting the fixing unit thermistor	1-6-34
	(3) Detaching and refitting the fixing heater	1-6-35
	(4) Detaching and refitting the heat roller separation claws	1-6-37
	(5) Detaching and refitting the heat roller	1-6-38
	(6) Detaching and refitting the press roller	1-6-38
1-7 Requirements on PCB Replacement		
1-7-1	Replacing the main PCB	1-7-1
1-7-2	Upgrading the firmware on the main PCB	1-7-3
1-7-3	Adjustment-free variable resistors (VR)	1-7-4
2-1 Mechanical construction		
2-1-1	Paper feed section	2-1-1
2-1-2	Main charging section	2-1-3
2-1-3	Optical section	2-1-5
	(1) Original scanning	2-1-6
	(2) Image printing	2-1-8
2-1-4	Developing section	2-1-10
	(1) Formation of magnetic brush	2-1-11
	(2) Toner density detection by the toner sensor	2-1-12
	(3) Toner density control	2-1-12
	(4) Correcting the toner sensor control voltage	2-1-13
	(5) Correcting toner output voltage	2-1-14
2-1-5	Transfer and separation section	2-1-15
2-1-6	Cleaning section	2-1-17
2-1-7	Charge erasing section	2-1-18
2-1-8	Fixing section	2-1-19
2-2 Electrical Parts Layout		
2-2-1	Electrical parts layout	2-2-1
	(1) PCBs	2-2-1
	(2) Switches and sensors	2-2-2
	(3) Motors	2-2-3
	(4) Other electrical components	2-2-4
2-3 Operation of the PCBs		
2-3-1	Power source PCB	2-3-1
2-3-2	Main PCB	2-3-4
2-3-3	Operation PCB	2-3-8
2-3-4	CCD PCB	2-3-10
2-3-5	Laser diode PCB	2-3-11
2-4 Appendixes		
	Timing chart No. 1	2-4-1
	Timing chart No. 2	2-4-2
	Timing chart No. 3	2-4-3
	Chart of image adjustment procedures	2-4-4
	Wiring diagram	2-4-7

1-1-1 Specifications

Type	Desktop
Copying system	Indirect electrostatic system
Originals	Sheets of paper, books, 3-dimensional objects (Maximum original size: folio/8 ¹ / ₂ " × 14")
Original feed system	Contact glass: fixed
Copy paper	Drawer: Plain paper (64 - 80 g/m ²) Bypass table: Plain paper (60 - 160 g/m ²) Special paper: Transparencies, letterhead and colored paper Note: Use the bypass table for special paper.
Copying sizes	Maximum: folio/8 ¹ / ₂ " × 14" Minimum: A6R /5 ¹ / ₂ " × 8 ¹ / ₂ "R (When the bypass table is used)
Magnification ratios	Manual mode: 50 - 200%, 1% increments
Copy speed	At 100% magnification in copy mode: A4R/8 ¹ / ₂ " × 11"R: 15 copies/min.
First copy time	Within 6.3 s (A4R/8 ¹ / ₂ " × 11"R, original placed on the platen)
Warm-up time	Within 30 s (room temperature 20°C/68°F, humidity 65% RH) In preheat/energy saver mode: Within 30 s (room temperature 20°C/68°F, humidity 65% RH) [priority to power save] In preheat/energy saver mode: Within 10 s (room temperature 20°C/68°F, humidity 65% RH) [priority to recovery]
Paper feed system	Automatic feed Capacity: Drawer: 250 sheets Manual feed Capacity: Bypass: 50 sheets
Continuous copying	1 - 99 sheets
Photoconductor	OPC (drum diameter 30 mm)
Charging system	Single positive corona charging
Exposure light source	Semiconductor laser
Developing system	Dry, reverse developing (magnetic brush) Developer: 2-component, ferrite carrier and N29T black toner Toner density control: toner sensor Toner replenishing: automatic from a toner container
Transfer system	Transfer roller
Fixing system	Heat roller Heat source: halogen heaters (900 W for 120 V specifications/1030 W for 220 - 240 V specifications) Control temperature: 180°C/356°F (at normal ambient temperature) Abnormally high temperature protection device: 150°C/302°F thermostat Fixing pressure: 36.28 N
Charge erasing system	Exposure by cleaning lamp
Cleaning system	Cleaning blade
Scanning system	Flat bed scanning by CCD image sensor
Resolution	600 × 600 dpi
Light source	Inert gas lamp
Dimensions	497 (W) × 497 (D) × 376 (H) mm 19 ⁹ / ₁₆ " (W) × 19 ⁹ / ₁₆ " (D) × 14 ¹³ / ₁₆ " (H)
Weight	Approx. 21 kg/46.2 lbs
Floor requirements	691 (W) × 497 (D) mm 27 ³ / ₁₆ " (W) × 19 ⁹ / ₁₆ " (D)
Functions	Self-diagnostics, preheat, automatic copy density control, enlargement/reduction copy and photo mode
Power source	120 V AC, 60 Hz, 9 A 220 - 240 V AC, 50/60 Hz, 4.8 A (average 2.5 A)
Power consumption	1080 W (120V) 1152 W (220 - 240V) (Measured value: 982 W (120V)/1131 W (220 - 240V))

1-1-2 Parts names

(1) Copier

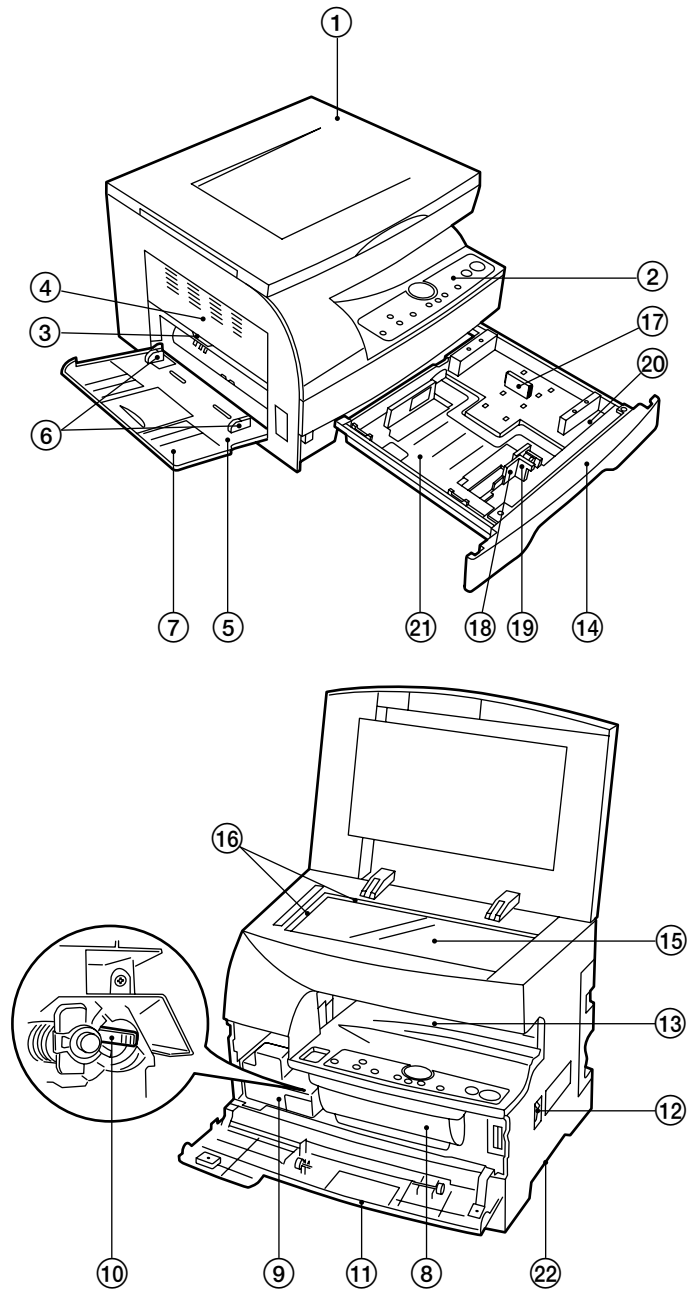
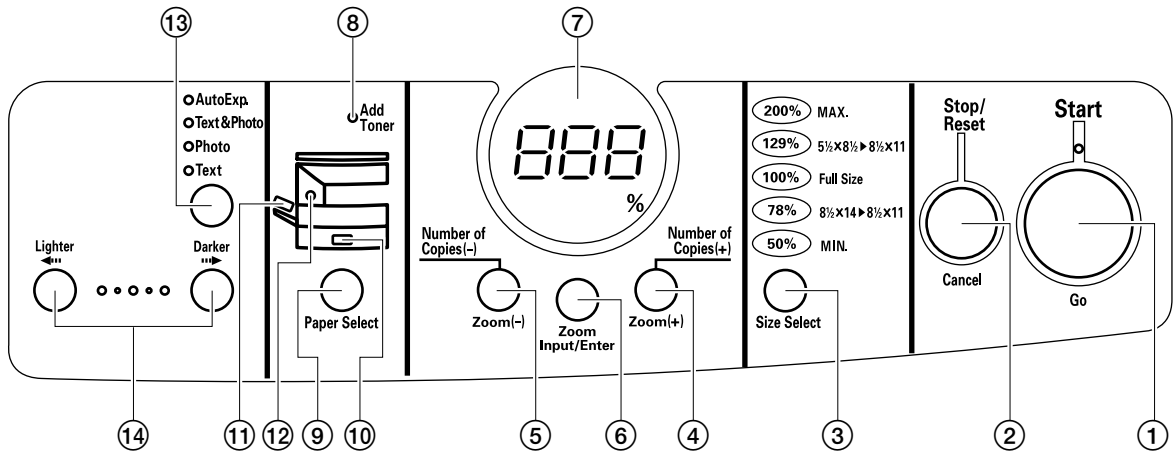

Figure 1-1-1

- | | |
|--------------------------------|--------------------------------|
| ① Original cover | ⑫ Main switch |
| ② Operation panel | ⑬ Copy storage section |
| ③ Paper conveying cover handle | ⑭ Drawer |
| ④ Paper conveying cover | ⑮ Platen |
| ⑤ Multi-Bypass | ⑯ Original size scales |
| ⑥ Insert guides | ⑰ Length guide |
| ⑦ Support guide | ⑱ Width guide |
| ⑧ Toner container | ⑲ Width adjustment lever |
| ⑨ Waste toner tank | ⑳ Length guide storage section |
| ⑩ Cleaning shaft | ㉑ Drawer bottom plate |
| ⑪ Front cover | ㉒ Hnadles for transport |

(2) Operation panel

Inch



Metric

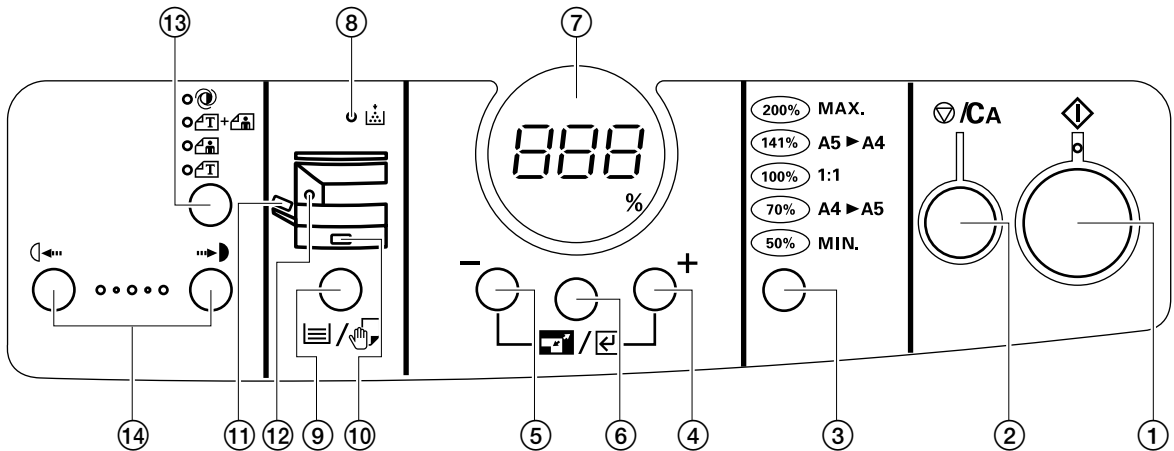

Figure 1-1-2

- ① Start key (Indicator)
- ② Stop/Reset key
- ③ Size Select key
- ④ Number of Copies/Zoom (+) key
- ⑤ Number of Copies/Zoom (-) key
- ⑥ Zoom Input/Enter key
- ⑦ Copy quantity/magnification display
- ⑧ Add Toner indicator
- ⑨ Paper Select key
- ⑩ Drawer indicator
- ⑪ Multi-bypass indicator
- ⑫ Misfeed indicator
- ⑬ Image mode selection key
- ⑭ Copy exposure adjustment keys

1-1-3 Machine cross section

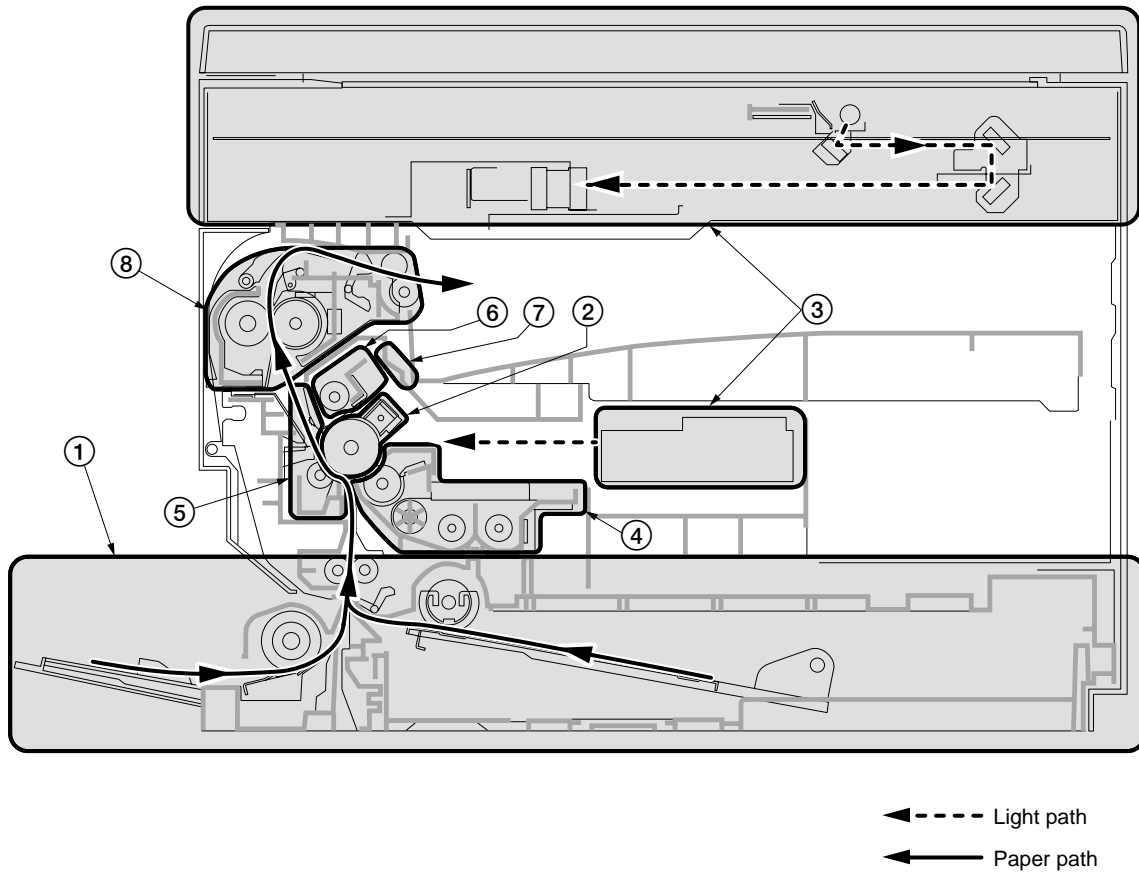

Figure 1-1-3 Machine cross section

- ① Paper feed section
- ② Main charging section
- ③ Optical section
- ④ Developing section
- ⑤ Transfer and separation section
- ⑥ Cleaning section
- ⑦ Charge erasing section
- ⑧ Fixing section

1-1-4 Drive system

(1) Drive system 1 (drive motor drive train)

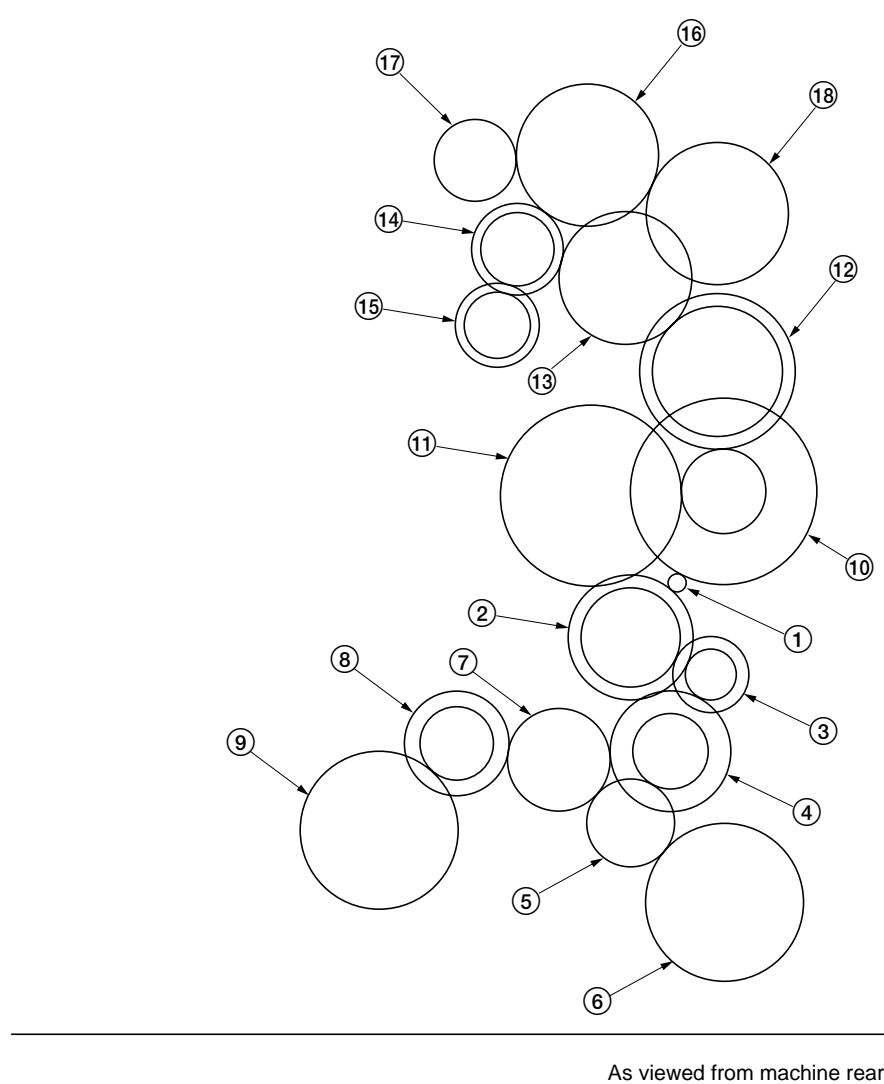

Figure 1-1-4

- | | |
|---------------------------------|-----------------------|
| ① Drive motor gear | ⑩ Gear 97/25 |
| ② Gear 67/30 | ⑪ Drum drive gear 53 |
| ③ Gear 23/16 | ⑫ Gear 40/45 |
| ④ Gear 37/21 | ⑬ Gear 41 |
| ⑤ Gear 23 | ⑭ Gear 28/20 |
| ⑥ Bypass paper feed clutch gear | ⑮ Gear 26/20 |
| ⑦ Registration clutch gear | ⑯ Fixing idle gear 44 |
| ⑧ Gear 32/18 | ⑰ Gear 25 |
| ⑨ Paper feed clutch gear | ⑱ Heat roller gear |

(2) Drive system 2 (scanner motor drive train)

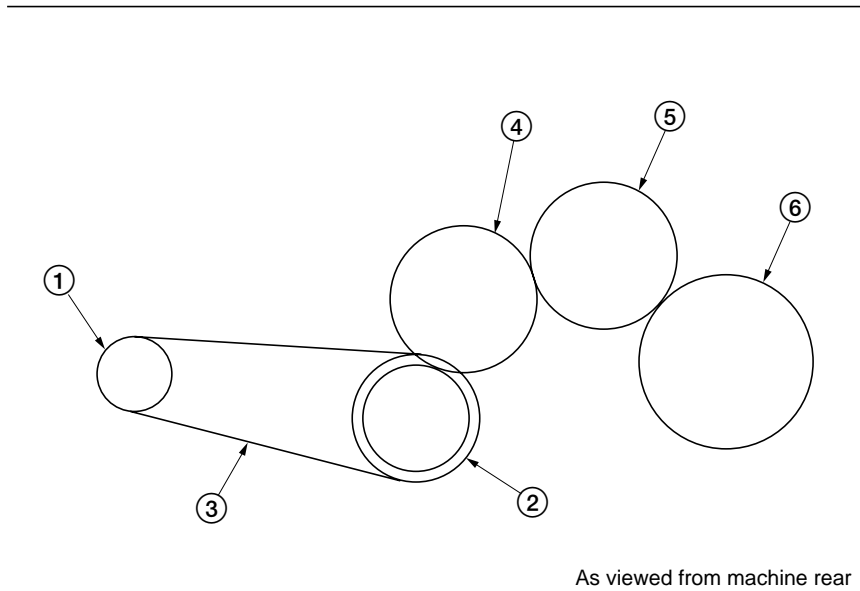

Figure 1-1-5

- ① Scanner motor gear
- ② Scanner drive gear 27/13
- ③ Scanner belt
- ④ Gear Z23
- ⑤ Idle gear 21
- ⑥ Gear Z30

1-2-1 Drum

Note the following when handling or storing the drum.

- When removing the image formation unit, never expose the drum surface to strong direct light.
- Keep the drum at an ambient temperature between 10°C/50°F and 32.5°C/90.5°F and at a relative humidity not higher than 85% RH. Avoid abrupt changes in temperature and humidity.
- Avoid exposure to any substance which is harmful to or may affect the quality of the drum.
- Do not touch the drum surface with any object. Should it be touched by hands or stained with oil, clean it.

1-2-2 Developer and toner

Store the developer and toner in a cool, dark place. Avoid direct light and high humidity.

1-2-3 Installation environment

1. Temperature: 10 - 32.5°C/50 - 90.5°F
2. Humidity: 20 - 85%RH
3. Power supply: 120 V AC, 9 A
220 - 240 V AC, 4.8 A (average 2.5 A)
4. Power source frequency: 50 Hz ±0.3%/60 Hz ±0.3%
5. Installation location
 - Avoid direct sunlight or bright lighting. Ensure that the photoconductor will not be exposed to direct sunlight or other strong light when removing paper jams.
 - Avoid extremes of temperature and humidity, abrupt ambient temperature changes, and hot or cold air directed onto the machine.
 - Avoid dust and vibration.
 - Choose a surface capable of supporting the weight of the machine.
 - Place the machine on a level surface (maximum allowance inclination: 1°).
 - Avoid air-borne substances that may adversely affect the machine or degrade the photoconductor, such as mercury, acidic or alkaline vapors, inorganic gasses, NOx, SOx gases and chlorine-based organic solvents.
 - Select a room with good ventilation.
6. Allow sufficient access for proper operation and maintenance of the machine.
 Machine front: 1000 mm/39³/₈" Machine rear: 300 mm/11¹³/₁₆"
 Machine right: 300 mm/11¹³/₁₆" Machine left: 500 mm/19¹¹/₁₆"

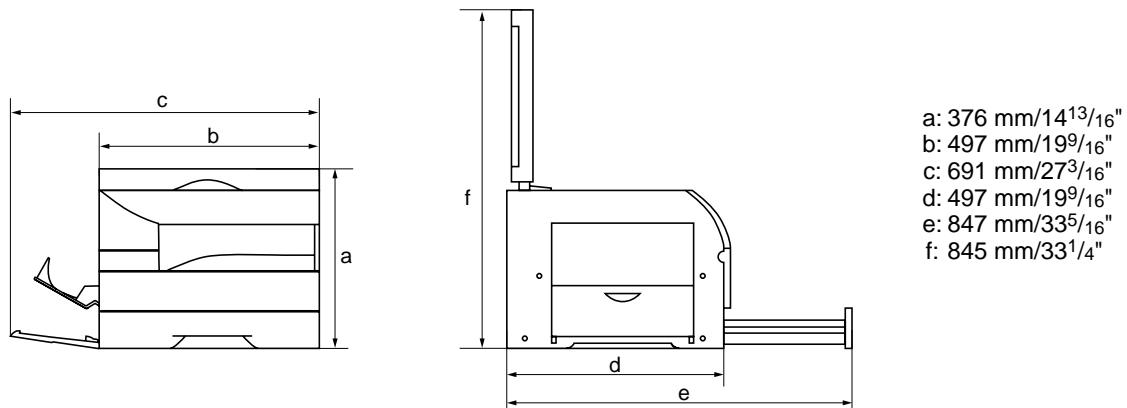
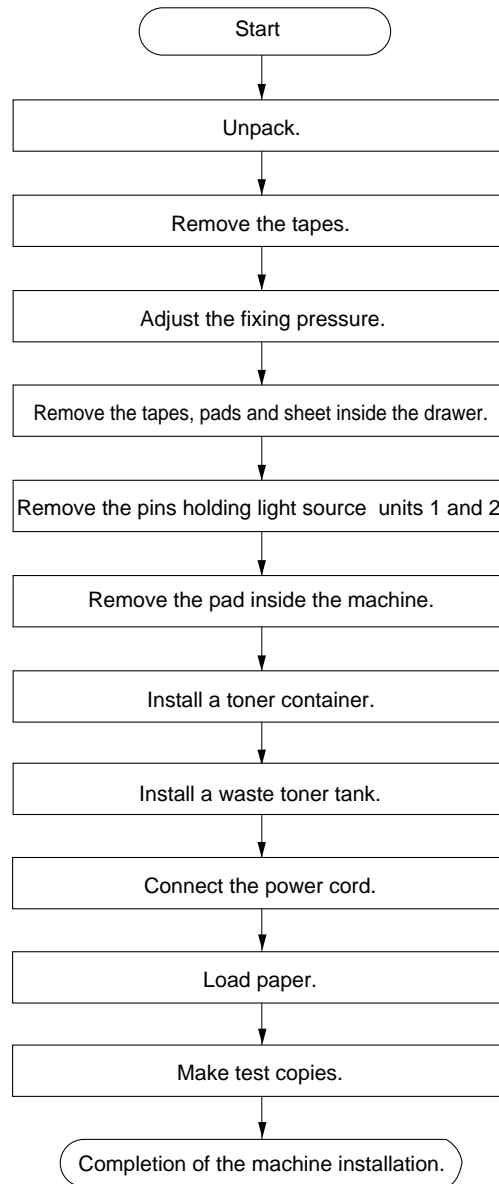

Figure 1-2-1 Installation dimensions

1-3-1 Unpacking and installation

(1) Installation procedure

**Caution:**

Be sure to install a waste toner tank when setting the machine.

Unpack.

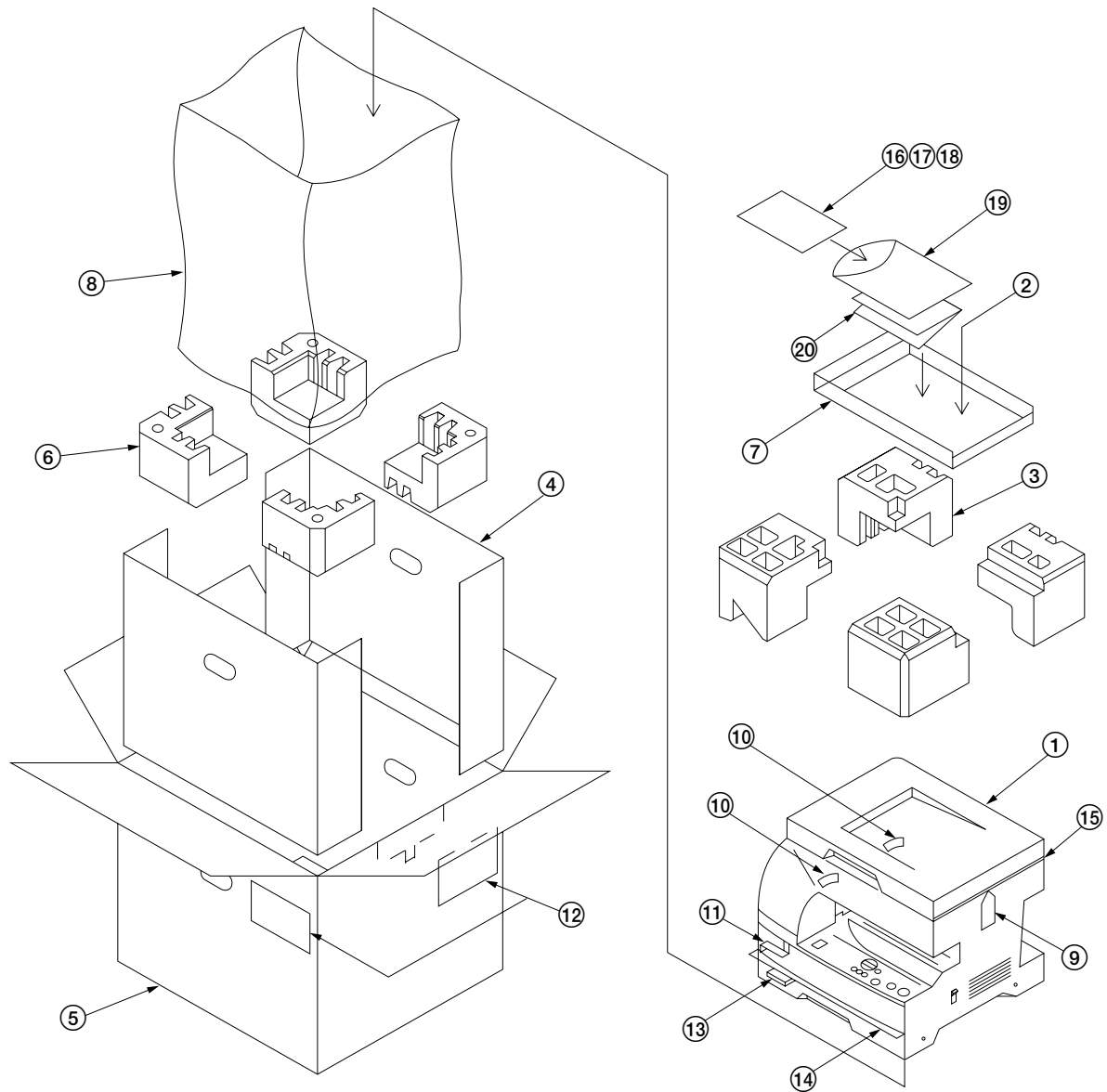

Figure 1-3-1 Unpacking

- | | |
|---------------------|--|
| ① Copier | ⑪ Waste toner tank spacer |
| ② Power cord | ⑫ Bar code labels |
| ③ Upper pads | ⑬ Drawer spacer |
| ④ Stay | ⑭ Front drawer spacer |
| ⑤ Outer case | ⑮ Sheet |
| ⑥ Bottom pads | ⑯ Instruction handbook |
| ⑦ Tray spacer | ⑰ Installation manual |
| ⑧ Machine cover | ⑱ Business reply mail (120 V specs only) |
| ⑨ Scanner pin tag | ⑲ Plastic bag |
| ⑩ Fixing lever tags | ⑳ Paper storage bag |

Remove the tapes.

1. Remove the 11 tapes.

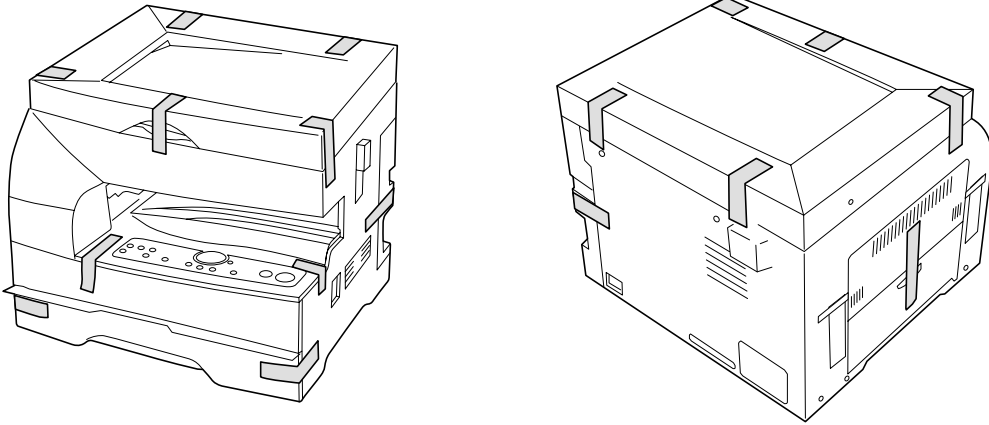

Figure 1-3-2

2. Open the bypass tray and paper conveying cover and then remove the two tapes.

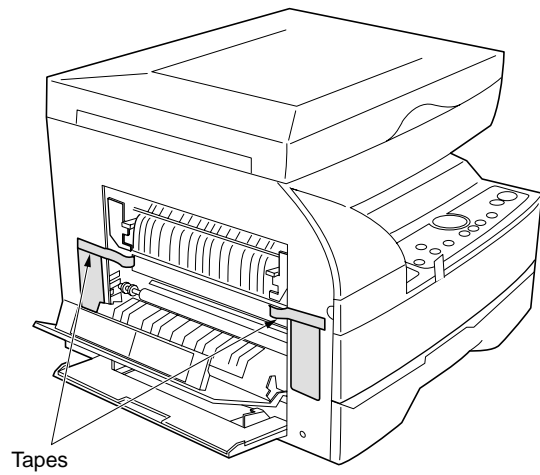
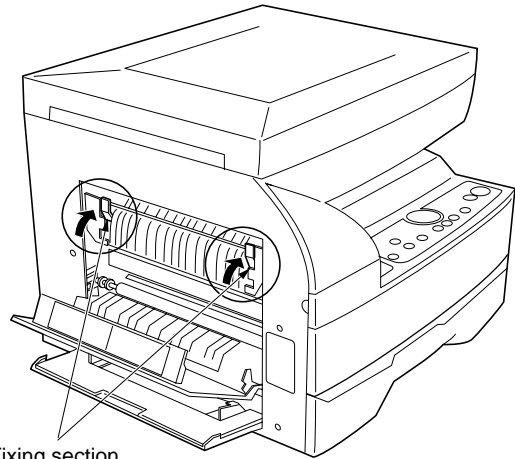

Figure 1-3-3

Adjust the fixing pressure.

3. Lift the fixing section release levers and close the paper conveying cover.



Fixing section release levers

Figure 1-3-4

Remove the tapes, pads and sheet inside the drawer.

4. Pull the drawer out and remove the tapes and two pads.
Caution: Be sure to load paper after the main switch is turned on and copying is enabled. Loading paper before turning the main switch on may cause paper jams.

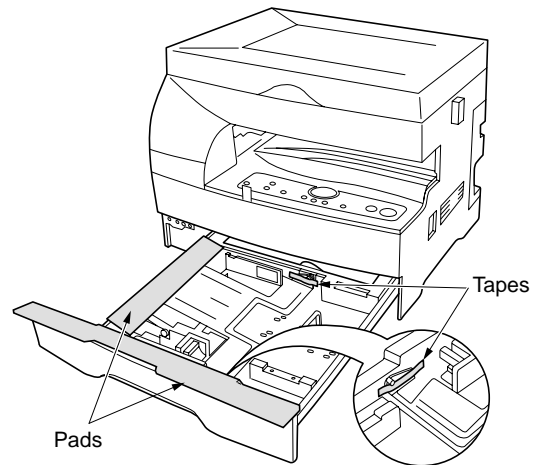

Figure 1-3-5

5. Open the original cover and remove the sheet on the contact glass.

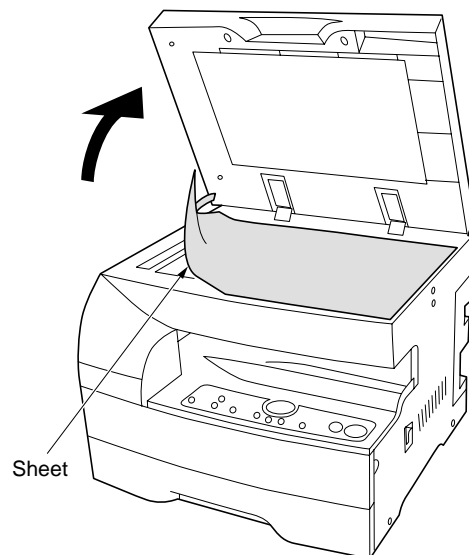

Figure 1-3-6

Remove the pins holding light source units 1 and 2.

6. Remove the tapes and two pins for light source unit 1 and 2.

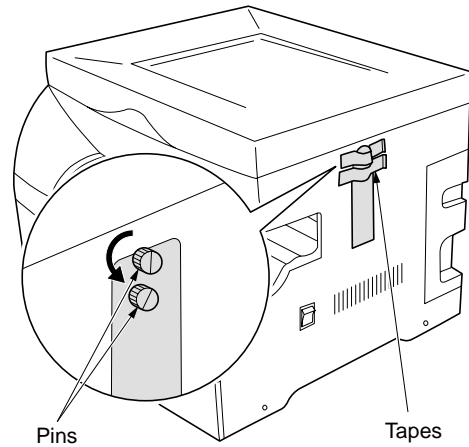

Figure 1-3-7

7. Open the front cover and store the removed pins by securing them on the inside of the cover. The storing locations of the pins are marked inside the front cover.

Caution: Be sure to refit the pins whenever the copier is moved.

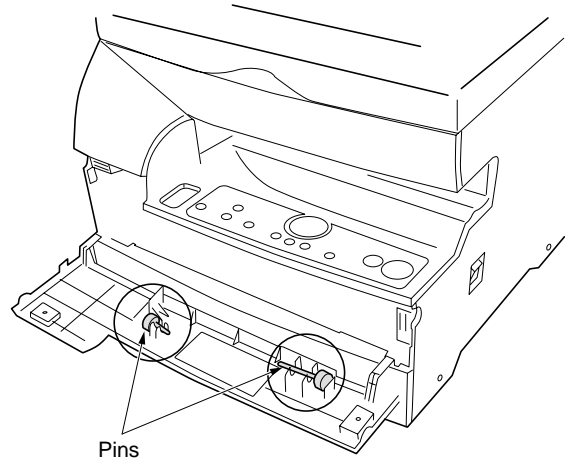

Figure 1-3-8

Remove the pad inside the machine.

8. Remove the pad. (This step is not necessary for metric specification copiers.)

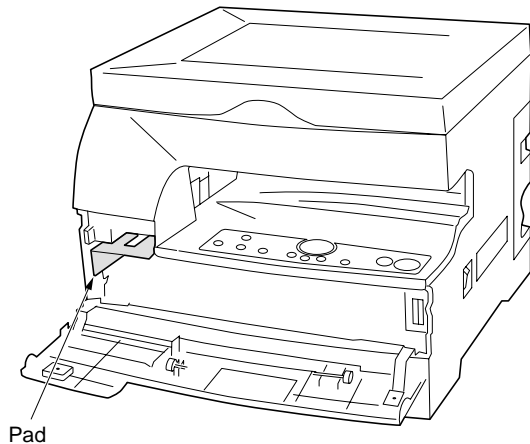

Figure 1-3-9

Install a toner container.

9. Hold the toner container vertically and tap the top 15 times. Turn the container upside-down and tap the top 15 times. Then, hold the container horizontally and shake it from side to side 10 times.

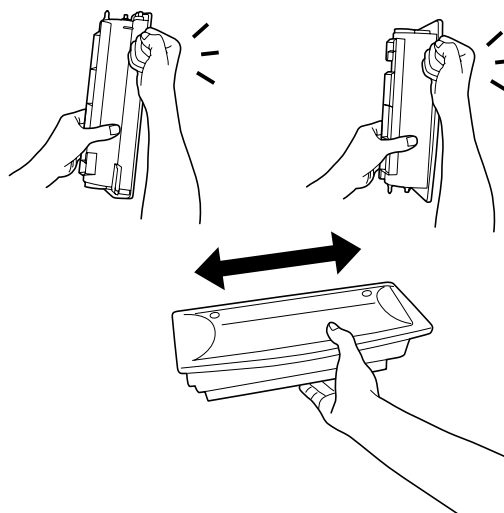

Figure 1-3-10

10. Insert the toner container into the copier as far as it will go and then slide it to the right as indicated by the marked arrows.

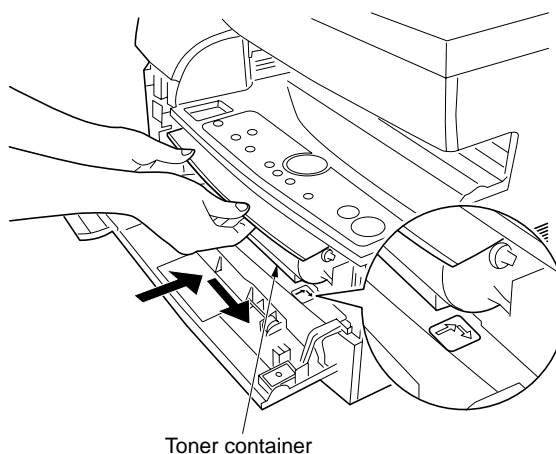

Figure 1-3-11

Install a waste toner tank.

- 11. Install the waste toner tank and close all the covers and drawers.

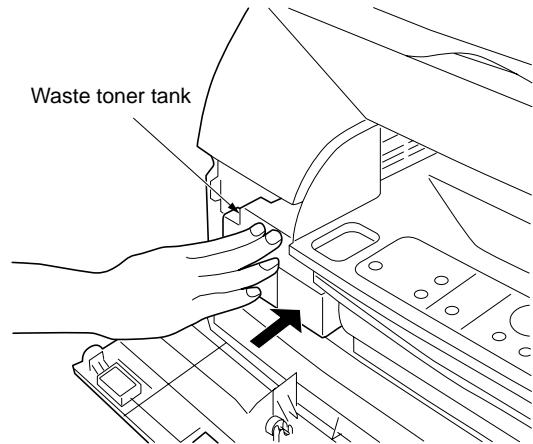

Figure 1-3-12

Connect the power cord.

- 12. Connect the power cord and turn the main switch on.
Caution: Never turn the power off or open covers while the copier is driving. Doing so may cause printing problems or contaminate the copier internally.

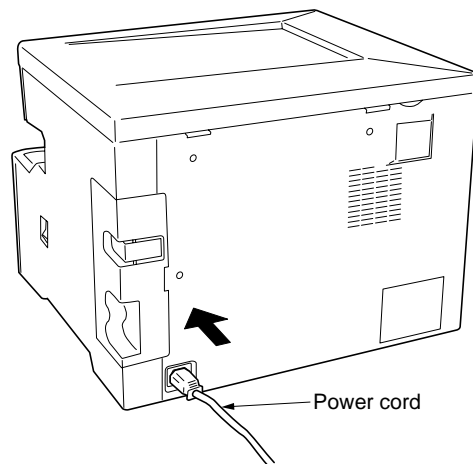

Figure 1-3-13

Load paper.

- 13. Pull the drawer out as far as it will go.
- 14. Press the drawer bottom plate down and lock it there.

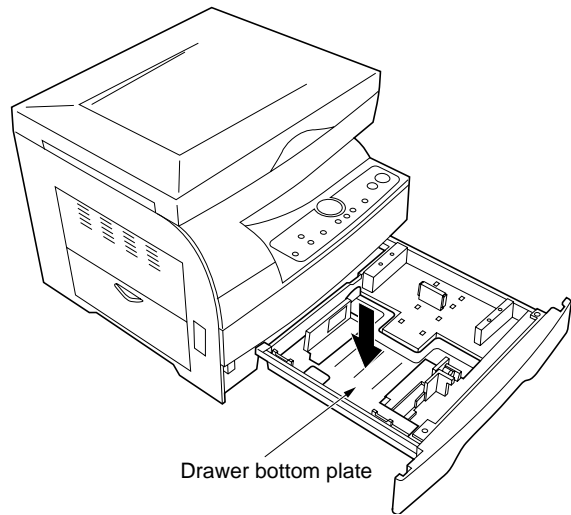

Figure 1-3-14

- 15. Holding the width adjustment lever, move it to align the width guide with the required paper width.

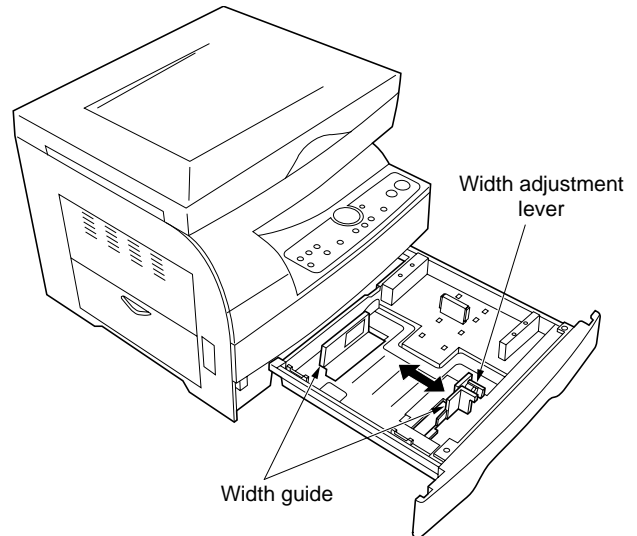

Figure 1-3-15

- 16. While squeezing the presses on the sides, remove the length guide and then insert it into the holes of the required paper length. Store the length guide in the space shown in the diagram when the paper touches the right-hand wall of the drawer.

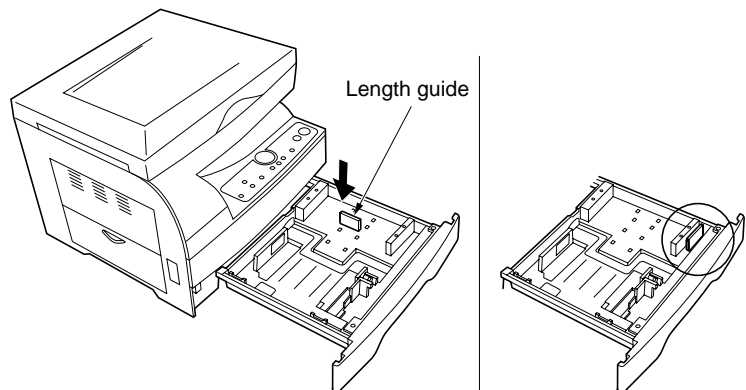

Figure 1-3-16

17. Set the paper flush against the left-hand wall of the drawer.
 - * Load paper so that it is kept under the claw of the drawer.
 - * When loading paper into the drawer, make sure that the copy side is facing upward (the copy side is the side facing upward when the package is opened.)
 - * Check that the length and width guides securely contact the paper. If there is a gap, adjust the position of the length or width guide to close it.
 - * Load paper all at once and do not add paper until all sheets are used up. Adding paper to a drawer that still contains paper may cause paper jams.
18. Push the drawer back in gently.
 - * Check that the paper is kept under the claw of the drawer. If not, reload the paper.

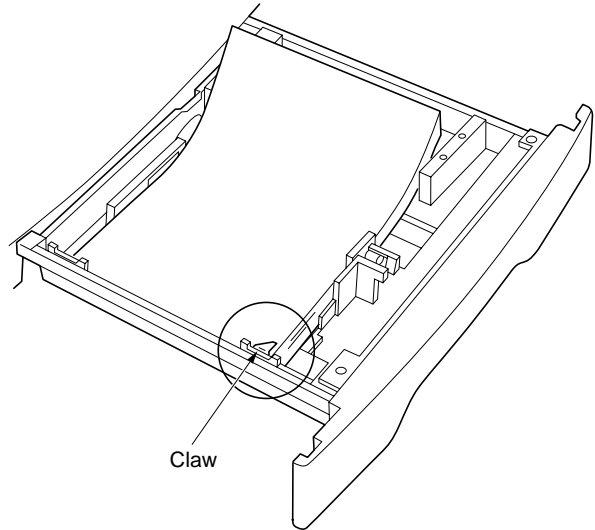

Figure 1-3-17

Make test copies.

19. Set the original and make test copies.

Completion of machine installation.

2BT

1-3-2 Setting initial copy modes

Factory settings are as follows:

Maintenance item No.	Contents	Factory setting
U254	Turning auto start function on/off	On
U255	Setting auto clear time	90 s
U256	Turning auto preheat/energy saver function on/off	On
U258	Switching copy operation at toner empty detectionempty detection	Single mode, 70
U260	Changing the copy count timing	After ejection
U348	Setting the copy density adjustment range	Normal

1-3-3 Copier management

In addition to a maintenance function for service, the copier is equipped with a management function which can be operated by users (mainly by the copier administrator). In this copier management mode, default settings can be changed.

(1) Executing a copier management item

- Executing a default setting item

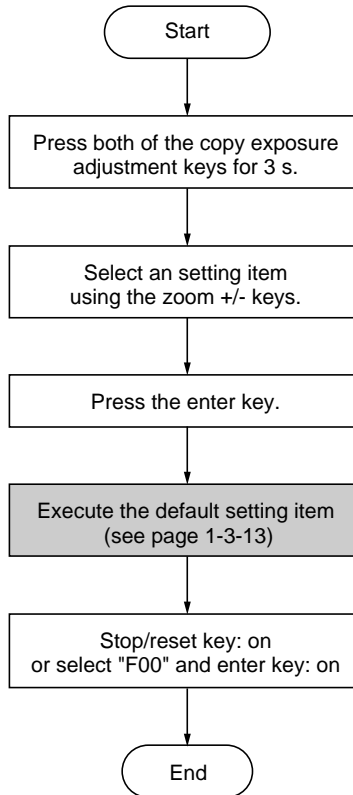

(2) Default settings**User status report**

Outputs the details of the default settings.

1. Select "F01" and press the enter key.
User status report is printed out.

Exposure mode

Selects the image mode at power-on.

1. Select "F02" and press the enter key.
2. Select the exposure mode and press the enter key.

Exposure mode: 1 (auto exposure)/
2 (text and photo)/3 (photo)/4 (text)

Exposure steps

Sets the number of exposure steps for the manual exposure mode.

1. Select "F03" and press the enter key.
2. Select "3 steps" or "5 steps" and press the enter key.

Setting range: 1 (3 steps)/2 (5 steps)

Auto exposure adjustment

Adjusts the exposure for the auto exposure mode.

1. Select "F04" and press the enter key.
2. Select the setting and press the enter key.
Setting range: 1 to 5

Text and photo original exposure adjustment

Adjusts the exposure to be used when text and photo original is selected for the image mode.

1. Select "F05" and press the enter key.
2. Select the setting and press the enter key.
Setting range: 1 to 5

Photo original exposure adjustment

Adjusts the exposure to be used when photo original is selected for the image mode.

1. Select "F06" and press the enter key.
2. Select the setting and press the enter key.
Setting range: 1 to 5

Text original exposure adjustment

Adjusts the exposure to be used when text original is selected for the image mode.

1. Select "F07" and press the enter key.
2. Select the setting and press the enter key.
Setting range: 1 to 5

Drawer paper size

Sets the size of paper loaded in the drawer.

1. Select "F08" and press the enter key.
2. Select the size of paper and press the enter key.
Paper size: 1 (A4R/8¹/₂" × 14")/2 (A5R/8¹/₂" × 11"R)/3 (Folio/5¹/₂" × 8¹/₂"R)

Non-standard size paper for the bypass tray

Sets if non-standard size paper is available when the paper is fed from the bypass tray.

1. Select "F09" and press the enter key.
2. Select "on" or "off" and press the enter key.
Setting range: 1 (on)/2 (off)

Non-standard size paper width setting for bypass tray

Sets the paper width when non-standard size is fed from the bypass tray.

1. Select "F10" and press the enter key.
2. Enter the setting and press the enter key.
Setting range is 4.13" to 8.50" (105 to 216 mm).
Note: This setting item will not be displayed if "off" is selected in "Non-standard size paper for the bypass tray".

Copy limit

Sets the limit of the number of copies that can be made at a time.

1. Select "F11" and press the enter key.
2. Enter the setting and press the enter key.
Setting range is 1 to 99 copies.

Silent mode

Sets the length of time from when copying ends to when entering the silent mode.

1. Select "F12" and press the enter key.
2. Select the setting and press the enter key.
Setting range: 1 (0 s)/2 (5 s)/3 (10 s)/4 (15 s)/5 (30 s)

Auto shut-off

Sets if the auto shut-off function is available.

1. Select "F13" and press the enter key.
2. Select "on" or "off" and press the enter key.
Setting range: 1 (on)/2 (off)

Auto preheat time

Sets the auto preheat time.

1. Select "F14" and press the enter key.
2. Select the setting and press the enter key.
Setting is available between 5 and 45 min. in 5 min. steps.
Setting range: 1 (5 min.)/2 (10 min.)/3 (15 min.)/4 (20 min.)/5 (25 min.)/6 (30 min.)/7 (35 min.)/8 (40 min.)/9 (45 min.)
Sets the auto preheat time to be shorter than the auto shutoff time.

Auto shutoff time

Sets the auto shut-off time.

1. Select "F15" and press the enter key.
2. Select the setting and press the enter key.
Setting is available between 15 and 120 min. in 15 min. steps.
Setting range: 1 (15 min.)/2 (30 min.)/3 (45 min.)/4 (60 min.)/5 (75 min.)/6 (90 min.)/7 (105 min.)/8 (120 min.)

Preheat recovery time

Selects the mode of the auto preheat function from recovery priority mode and power save priority mode.

1. Select "F16" and press the enter key.
2. Select the priority mode and enter key: on
Priority mode: 1 (recovery priority mode)/2 (power save priority mode)

Viewing total counter value

Displays the total number of copies.

1. Select "F17" and press the enter key.
The total number of copies are displayed on the copy quantity/magnification display.

Toner counter report

Outputs the report on the toner consumption ratio.

1. Select "F18" and press the enter key.
The list is printed out.

Toner replacement message output setting

Sets if a message requesting the user to replace the toner container is printed when the toner is used up.

1. Select "F19" and press the enter key.
2. Select "on" or "off" and press the enter key.
Setting range: 1 (on)/2 (off)

Paper feed shifting adjustment (drawer)

Adjusts displacement of the copy image.

1. Select "F20" and press the enter key.
2. Select the setting and press the enter key.
Setting range: -3.0 to +3.0 (1 steps moves 0.1)

Paper feed shifting adjustment (bypass tray)

Adjusts displacement of the copy image.

1. Select "F21" and press the enter key.
2. Select the setting and press the enter key.
Setting range: -3.0 to +3.0 (1 steps moves 0.1)
Use A4R/8¹/₂" × 11"R size paper.

Inch/metric specifications setting

Switches the copier specifications setting between inch and metric.

1. Select "F22" and press the enter key.
2. Select the specifications setting and press the enter key.
Specifications setting: 1 (inch)/2 (metric)/3 (metric for Japan)

Folio length setting (drawer)

Sets the length when folio is selected as the paper size.

1. Select "F23" and press the enter key.
2. Select the length and press the enter key.
Length: 1 (210 mm)/2 (216 mm)
This setting item is available only when metric is selected for the copier specifications.

Folio length setting (bypass tray)

Sets the length when folio is selected as the paper size.

1. Select "F24" and press the enter key.
2. Enter the setting and press the enter key.
Setting is available between 200 and 216 mm.
This setting item is available only when metric is selected for the copier specifications.

1-4-1 Maintenance mode

The copier is equipped with a maintenance function which can be used to maintain and service the machine.

(1) Executing a maintenance item

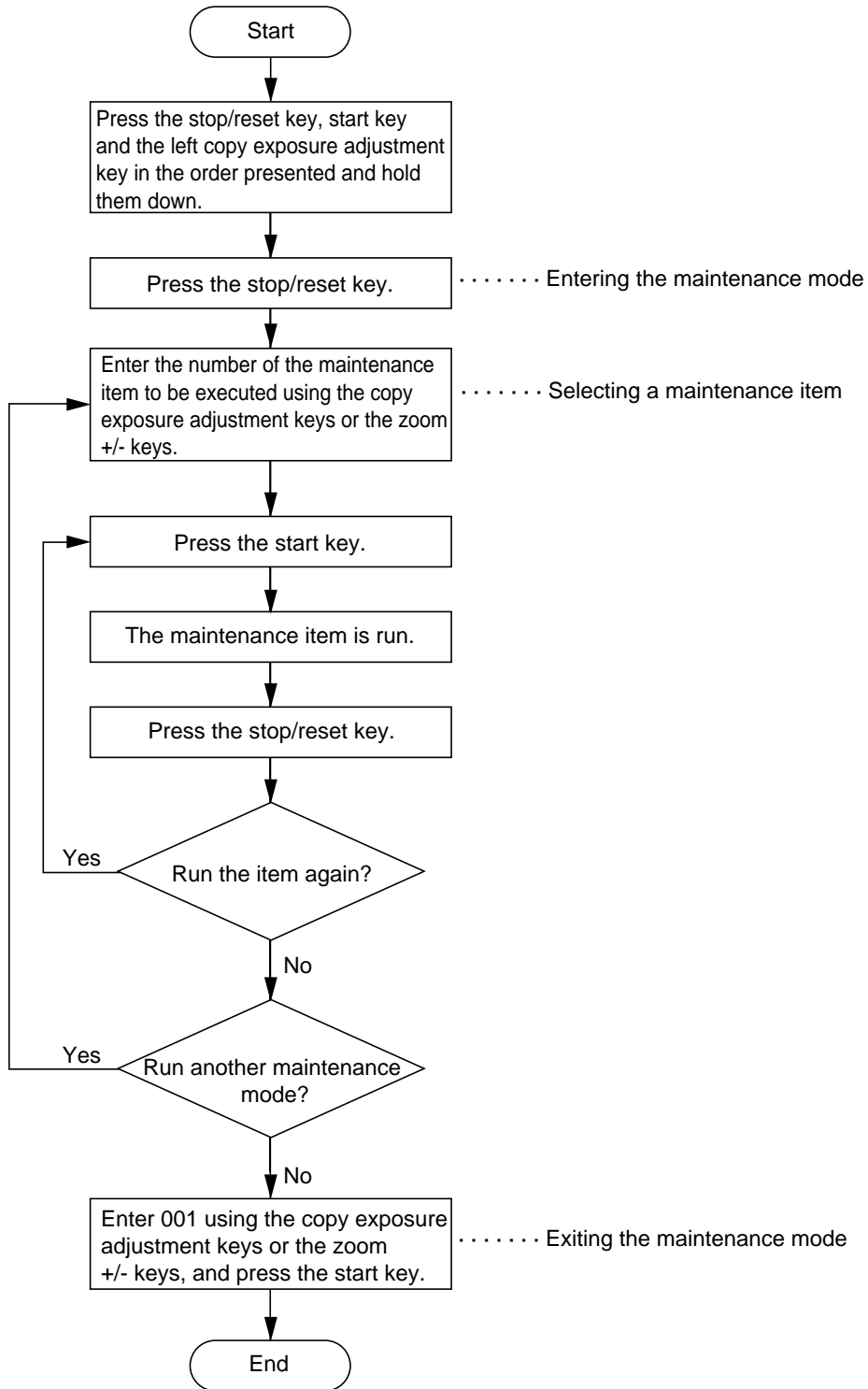

Caution:

Do not perform aging without the waste toner tank installed during maintenance service.

(2) Maintenance mode item list

Section	Item No.	Maintenance item contents	Initial setting*
General	U000	Outputting an own-status report	—
	U001	Exiting the maintenance mode	—
	U004	Setting the machine number	—
	U005	Copying without paper	—
Initialization	U020	Initializing all data	—
	U021	Initializing memories	—
	U022	Initializing backup data	—
Drive, paper feed, paper conveying and cooling system	U030	Checking motor operation	—
	U031	Checking switches for paper conveying	—
	U032	Checking clutch operation	—
	U033	Checking solenoid operation	—
	U034	Adjusting the print start timing • Adjusting the leading edge registration • Adjusting the center line	0 0
	U042	Setting the LSU type	b
	U051	Adjusting the amount of slack in the paper • Drawer • Bypass tray	0 0
	U053	Performing fine adjustment of the motor speed • Drive motor • Polygon motor	0 0
Optical	U060	Adjusting the scanner input properties	12
	U061	Turning the exposure lamp on	—
	U063	Adjusting the shading position	0
	U065	Adjusting the scanner magnification • Main scanning direction/auxiliary scanning direction	0
	U066	Adjusting the leading edge registration for scanning an original on the contact glass	0
	U067	Adjusting the center line for scanning an original on the contact glass	0
	U073	Checking scanner operation	—
	U088	Setting the input filter (moiré reduction mode)	Off
	U089	Outputting a MIP-PG pattern	—
	U091	Checking shading	—
	U092	Adjusting the scanner automatically	—
	U093	Setting the exposure density gradient • Text/text and photo/photo mode	0
	High voltage	U100	Setting the surface potential
U101		Setting high voltages • Developing bias • Transfer voltage • Transfer voltage output timing	200/34 94 256/544
U109		Setting the drum type	b
U110		Checking/clearing the drum count	—
U111		Checking/clearing the drum drive time	—
Developing		U130	Initial setting for the developer
	U131	Setting the toner sensor control voltage	157
	U132	Replenishing toner forcibly	—
	U135	Checking toner feed motor operation	—
	U155	Displaying the toner sensor output	—

* Initial setting for executing maintenance item U020

Section	Item No.	Maintenance item contents	Initial setting*
Developing	U156	Changing the toner control level • Toner feed start level • Toner empty level	113 44
	U157	Checking/clearing the developing drive time	—
	U158	Checking/clearing the developing count	—
Fixing and cleaning	U161	Setting the fixing control temperature • Primary stabilization fixing temperature • Secondary stabilization fixing temperature	125 180
	U162	Stabilizing fixing forcibly	—
	U163	Resetting the fixing problem data	—
	U170	Setting the drum cleaning mode	Off
	U196	Turning the fixing heater on	—
	U199	Checking the fixing temperature	—
Operation panel and support equipment	U200	Turning all LEDs on	—
	U207	Checking the operation panel keys	—
	U208	Setting the paper size	8 ¹ / ₂ " × 11"
Mode setting	U252	Setting the destination	Inch
	U254	Turning auto start function on/off	On
	U255	Setting auto clear time	90
	U256	Turning auto preheat/energy saver function on/off	On
	U258	Switching copy operation at toner empty detection	Single mode, 70
	U260	Changing the copy count timing	After ejection
	U332	Setting the size conversion factor	—
	U348	Setting the copy density adjustment range	Normal
Image processing	U402	Adjusting margins for printing	—
	U403	Adjusting margins for scanning an original on the contact glass	—
Others	U901	Checking/clearing copy counts by paper feed locations	—
	U903	Checking/clearing the paper jam counts	—
	U904	Checking/clearing the service call counts	—
	U910	Clearing the black ratio data	—
	U917	Setting the reading/writing of backup data	Read
	U990	Checking/clearing the time for the exposure lamp to light	—
	U993	Outputting a VTC-PG pattern	—
	U998	Outputting the memory list	—





* Initial setting for executing maintenance item U020

(3) Contents of maintenance mode items

Maintenance item No.	Description												
U000	<p>Outputting an own-status report</p> <p>Description Outputs lists of the current settings of the maintenance items, and paper jam and service call occurrences.</p> <p>Purpose To check the current setting of the maintenance items, or paper jam or service call occurrences. Before initializing the backup RAM, output a list of the current settings of the maintenance items to reenter the settings after initialization or replacement.</p> <p>Method</p> <ol style="list-style-type: none"> 1. Press the start key. A selection item appears. 2. Select the item to be output using the copy exposure adjustment keys. <table border="1" style="width: 100%; border-collapse: collapse;"> <thead> <tr> <th style="text-align: left;">Display</th> <th style="text-align: left;">Output list</th> </tr> </thead> <tbody> <tr> <td>d-L</td> <td>List of the current settings of the maintenance modes</td> </tr> <tr> <td>J-L</td> <td>List of the paper jam occurrences</td> </tr> <tr> <td>C-L</td> <td>List of the service call occurrences</td> </tr> </tbody> </table> <ol style="list-style-type: none"> 3. Press the start key. The test copy mode is entered and a list is output. When A4/11" × 8¹/₂" paper is available, a report of this size is output. If not, specify the paper feed location. When output is complete, the selected item appears. <p>Completion Press the stop/reset key while a selection item is displayed. The indication for selecting a maintenance item No. appears.</p>	Display	Output list	d-L	List of the current settings of the maintenance modes	J-L	List of the paper jam occurrences	C-L	List of the service call occurrences				
Display	Output list												
d-L	List of the current settings of the maintenance modes												
J-L	List of the paper jam occurrences												
C-L	List of the service call occurrences												
U001	<p>Exiting the maintenance mode</p> <p>Description Exits the maintenance mode and returns to the normal copy mode.</p> <p>Purpose To exit the maintenance mode.</p> <p>Method Press the start key. The normal copy mode is entered.</p>												
U004	<p>Setting the machine number</p> <p>Description Displays and changes the machine number.</p> <p>Purpose To check or set the machine number.</p> <p>Method Press the start key. The currently set machine number is displayed.</p> <p>Setting</p> <ol style="list-style-type: none"> 1. Select the item by lighting a copy exposure indicator using the copy exposure adjustment keys. 2. Enter the last six digits of the machine number using the numeric or zoom +/- keys. Do not enter the first two digits, 3 and 7. <table border="1" style="width: 100%; border-collapse: collapse;"> <thead> <tr> <th style="text-align: left;">Copy exposure indicator</th> <th style="text-align: left;">Description</th> <th style="text-align: left;">Setting range</th> <th style="text-align: left;">Initial setting</th> </tr> </thead> <tbody> <tr> <td>Exp. 1</td> <td>First 3 digits</td> <td>000 to 999</td> <td>000</td> </tr> <tr> <td>Exp. 3</td> <td>Last 3 digits</td> <td>000 to 999</td> <td>000</td> </tr> </tbody> </table> <ol style="list-style-type: none"> 3. Press the start key. The machine number is set. The indication for selecting a maintenance item No. appears. <p>Completion To exit this maintenance item without changing the current setting, press the stop/reset key. The indication for selecting a maintenance item No. appears.</p>	Copy exposure indicator	Description	Setting range	Initial setting	Exp. 1	First 3 digits	000 to 999	000	Exp. 3	Last 3 digits	000 to 999	000
Copy exposure indicator	Description	Setting range	Initial setting										
Exp. 1	First 3 digits	000 to 999	000										
Exp. 3	Last 3 digits	000 to 999	000										

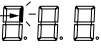
Maintenance item No.	Description						
<p>U005</p>	<p>Copying without paper</p> <p>Description Simulates the copy operation without paper feed.</p> <p>Purpose To check the overall operation of the machine.</p> <p>Method</p> <ol style="list-style-type: none"> 1. Press the start key. A selection item appears. 2. Select the item to be operated using the copy exposure adjustment keys. <table border="1" data-bbox="320 512 1382 595"> <thead> <tr> <th>Display</th> <th>Operation</th> </tr> </thead> <tbody> <tr> <td>P</td> <td>Only the copier operates.</td> </tr> </tbody> </table> <ol style="list-style-type: none"> 3. Press the interrupt key. 4. Set the operation conditions required. Changes in the following settings can be made. <ul style="list-style-type: none"> • Paper feed locations • Magnifications • Copy density • Keys on the operation panel other than the energy saver (preheat) key 5. To control the paper feed pulley, remove all the paper in the drawers, or the drawers. With the paper present, the paper feed pulley does not operate. 6. Press the start key. The operation starts. Copy operation is simulated without paper under the set conditions. When operation is complete, the selected item appears. 7. To stop continuous operation, press the stop/reset key. <p>Completion Press the stop/reset key at the screen for selecting an item. The indication for selecting a maintenance item No. appears.</p>	Display	Operation	P	Only the copier operates.		
Display	Operation						
P	Only the copier operates.						
<p>U020</p>	<p>Initializing all data</p> <p>Description Initializes all the backup RAM on the main PCB to return to the original settings.</p> <p>Purpose Used when replacing the main PCB.</p> <p>Method</p> <ol style="list-style-type: none"> 1. Press the start key. 2. Select "on" using the zoom +/- keys. <table border="1" data-bbox="320 1314 1382 1426"> <thead> <tr> <th>Display</th> <th>Operation</th> </tr> </thead> <tbody> <tr> <td>---</td> <td>Canceling initialization</td> </tr> <tr> <td>on</td> <td>Executing initialization</td> </tr> </tbody> </table> <ol style="list-style-type: none"> 3. Press the start key. All data in the backup RAM is initialized, and the original settings for inch specifications are set. When initialization is complete, the machine automatically returns to the same status as when the main switch is turned on. <p>Completion To exit this maintenance item without executing initialization, press the stop/reset key. The indication for selecting a maintenance item No. appears.</p>	Display	Operation	---	Canceling initialization	on	Executing initialization
Display	Operation						
---	Canceling initialization						
on	Executing initialization						

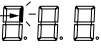
Maintenance item No.	Description												
<p>U021</p>	<p>Initializing memories</p> <p>Description Initializes the setting data other than that for adjustments due to variations between respective machines, i.e., settings for counters, service call history and mode settings. As a result, initializes the backup RAM according to the specifications depending on the destination selected in U252.</p> <p>Purpose Used to return the machine settings to the factory settings.</p> <p>Method</p> <ol style="list-style-type: none"> 1. Press the start key. 2. Select "on" using the zoom +/- keys. <table border="1" style="width: 100%; border-collapse: collapse;"> <thead> <tr> <th style="width: 50%;">Display</th> <th style="width: 50%;">Operation</th> </tr> </thead> <tbody> <tr> <td style="text-align: center;">---</td> <td>Canceling initialization</td> </tr> <tr> <td style="text-align: center;">on</td> <td>Executing initialization</td> </tr> </tbody> </table> <ol style="list-style-type: none"> 3. Press the start key. All data other than that for adjustments due to variations between machines is initialized based on the destination setting. When initialization is complete, the machine automatically returns to the same status as when the main switch is turned on. <p>Completion Press the stop/reset key. The indication for selecting a maintenance item No. appears.</p>	Display	Operation	---	Canceling initialization	on	Executing initialization						
Display	Operation												
---	Canceling initialization												
on	Executing initialization												
<p>U022</p>	<p>Initializing backup data</p> <p>Description Initializes only the data set for the engine or scanner section.</p> <p>Purpose To be executed after replacing the scanner unit.</p> <p>Method</p> <ol style="list-style-type: none"> 1. Press the start key. A selection item appears. 2. Select the item to be initialized using the copy exposure adjustment keys. <table border="1" style="width: 100%; border-collapse: collapse;"> <thead> <tr> <th style="width: 50%;">Display</th> <th style="width: 50%;">Operation</th> </tr> </thead> <tbody> <tr> <td style="text-align: center;">A</td> <td>Engine</td> </tr> <tr> <td style="text-align: center;">b</td> <td>Scanner</td> </tr> </tbody> </table> <ol style="list-style-type: none"> 3. Press the start key. 4. Select "on" using the zoom +/- keys. <table border="1" style="width: 100%; border-collapse: collapse;"> <thead> <tr> <th style="width: 50%;">Display</th> <th style="width: 50%;">Operation</th> </tr> </thead> <tbody> <tr> <td style="text-align: center;">---</td> <td>Canceling initialization</td> </tr> <tr> <td style="text-align: center;">on</td> <td>Executing initialization</td> </tr> </tbody> </table> <ol style="list-style-type: none"> 5. Press the start key. The data for the engine or scanner section (U060 to 099, U403, U404 and U990) is initialized. <p>Completion Press the stop/reset key. The indication for selecting a maintenance item No. appears.</p>	Display	Operation	A	Engine	b	Scanner	Display	Operation	---	Canceling initialization	on	Executing initialization
Display	Operation												
A	Engine												
b	Scanner												
Display	Operation												
---	Canceling initialization												
on	Executing initialization												

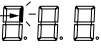
Maintenance item No.	Description								
<p>U030</p>	<p>Checking motor operation</p> <p>Description Drives the drive motor.</p> <p>Purpose To check the operation of the drive motor.</p> <p>Method</p> <ol style="list-style-type: none"> 1. Press the start key. A selection item appears. <table border="1" data-bbox="320 488 1382 568"> <thead> <tr> <th data-bbox="320 488 699 521">Display</th> <th data-bbox="699 488 1382 521">Motor</th> </tr> </thead> <tbody> <tr> <td data-bbox="320 521 699 568">A</td> <td data-bbox="699 521 1382 568">Drive motor (DM)</td> </tr> </tbody> </table> <ol style="list-style-type: none"> 2. Press the start key. The motor operates. 3. To stop operation, press the stop/reset key. <p>Completion Press the stop/reset key after operation stops. The indication for selecting a maintenance item No. appears.</p>	Display	Motor	A	Drive motor (DM)				
Display	Motor								
A	Drive motor (DM)								
<p>U031</p>	<p>Checking switches for paper conveying</p> <p>Description Displays the on-off status of each paper detection switch on the paper path.</p> <p>Purpose To check if the switches for paper conveying operate correctly.</p> <p>Method</p> <ol style="list-style-type: none"> 1. Press the start key. 2. Turn each switch on and off manually to check the status. While each switch is turned on, a segment of the 7-segment display lights. Segments of the 7-segment display and the switches correspond as follows: <table border="1" data-bbox="320 1021 1382 1216"> <thead> <tr> <th data-bbox="320 1021 821 1070">Segments of the 7-segment display</th> <th data-bbox="821 1021 1382 1070">Switch</th> </tr> </thead> <tbody> <tr> <td data-bbox="320 1070 821 1151"> ON →  </td> <td data-bbox="821 1070 1382 1151">Eject switch (ESW)</td> </tr> <tr> <td data-bbox="320 1151 821 1216"> ON →  </td> <td data-bbox="821 1151 1382 1216">Registration switch (RSW)</td> </tr> </tbody> </table> <p>Completion Press the stop/reset key. The indication for selecting a maintenance item No. appears.</p>	Segments of the 7-segment display	Switch	ON → 	Eject switch (ESW)	ON → 	Registration switch (RSW)		
Segments of the 7-segment display	Switch								
ON → 	Eject switch (ESW)								
ON → 	Registration switch (RSW)								
<p>U032</p>	<p>Checking clutch operation</p> <p>Description Turns each clutch on.</p> <p>Purpose To check the operation of each clutch.</p> <p>Method</p> <ol style="list-style-type: none"> 1. Press the start key. A selection item appears. 2. Select the clutch to be operated using the copy exposure adjustment keys. 3. Press the start key. The selected clutch turns on for 1 s. <table border="1" data-bbox="308 1583 1370 1724"> <thead> <tr> <th data-bbox="308 1583 687 1624">Display</th> <th data-bbox="687 1583 1370 1624">Clutch</th> </tr> </thead> <tbody> <tr> <td data-bbox="308 1624 687 1659">P1</td> <td data-bbox="687 1624 1370 1659">Paper feed clutch (PFCL)</td> </tr> <tr> <td data-bbox="308 1659 687 1693">Pb</td> <td data-bbox="687 1659 1370 1693">Bypass paper feed clutch (BYPPFCL)</td> </tr> <tr> <td data-bbox="308 1693 687 1724">2F</td> <td data-bbox="687 1693 1370 1724">Registration clutch (RCL)</td> </tr> </tbody> </table> <p>Completion Press the stop/reset key. The indication for selecting a maintenance item No. appears.</p>	Display	Clutch	P1	Paper feed clutch (PFCL)	Pb	Bypass paper feed clutch (BYPPFCL)	2F	Registration clutch (RCL)
Display	Clutch								
P1	Paper feed clutch (PFCL)								
Pb	Bypass paper feed clutch (BYPPFCL)								
2F	Registration clutch (RCL)								

Maintenance item No.	Description								
<p>U033</p>	<p>Checking main switch operation</p> <p>Description Turns the main switch on by energizing the main switch off solenoid.</p> <p>Purpose To check the operation of the main switch off solenoid in auto shutoff mode.</p> <p>Method</p> <ol style="list-style-type: none"> 1. Press the start key. "A" appears. 2. Press the start key. The main switch is turned on. <p>Completion Press the stop/reset key. The indication for selecting a maintenance item No. appears.</p>								
<p>U034</p>	<p>Adjusting the print start timing</p> <p>Adjustment See pages 1-6-8 and 9.</p>								
<p>U042</p>	<p>Setting the LSU type</p> <p>Description Sets the type of the LSU installed in the copier.</p> <p>Purpose Used when replacing the LSU.</p> <p>Method</p> <ol style="list-style-type: none"> 1. Press the start key. A selection item appears. 2. Select the LSU type using the zoom +/- keys. <table border="1" data-bbox="304 976 1369 1115"> <thead> <tr> <th>Display</th> <th>Description</th> </tr> </thead> <tbody> <tr> <td>A</td> <td>Type A</td> </tr> <tr> <td>b</td> <td>Type b</td> </tr> <tr> <td>C</td> <td>Type C</td> </tr> </tbody> </table> <p>Initial setting: b</p> <ol style="list-style-type: none"> 3. Press the start key. The setting is set. <p>Completion To exit this maintenance item without changing the current setting, press the stop/reset key. The indication for selecting a maintenance item No. appears.</p>	Display	Description	A	Type A	b	Type b	C	Type C
Display	Description								
A	Type A								
b	Type b								
C	Type C								
<p>U051</p>	<p>Adjusting the amount of slack in the paper</p> <p>Adjustment See page 1-6-11.</p>								

Maintenance item No.	Description												
U053	<p>Performing fine adjustment of the motor speed</p> <p>Description Performs fine adjustment of the speeds of the motors.</p> <p>Purpose Used to adjust the speed of the respective motors when the magnification is not correct.</p> <p>Method Press the start key.</p> <p>Setting</p> <ol style="list-style-type: none"> 1. Select the item by lighting a copy exposure indicator using the copy exposure adjustment keys. 2. Change the setting using the zoom +/- keys. <table border="1" data-bbox="320 577 1382 689"> <thead> <tr> <th>Copy exposure indicator</th> <th>Description</th> <th>Setting range</th> <th>Initial setting</th> </tr> </thead> <tbody> <tr> <td>Exp. 1</td> <td>Drive motor speed adjustment</td> <td>-7.0 to +7.0</td> <td>0</td> </tr> <tr> <td>Exp. 3</td> <td>Polygon motor speed adjustment</td> <td>-5.0 to +2.0</td> <td>0</td> </tr> </tbody> </table> <p>Drive motor speed adjustment (unit: %) Increasing the setting makes the image longer in the auxiliary scanning direction, and decreasing it makes the image shorter in the auxiliary scanning direction.</p> <p>Polygon motor speed adjustment (unit: %) Increasing the setting makes the image longer in the main scanning direction and shorter in the auxiliary scanning direction; decreasing the setting makes the image shorter in the main scanning direction and longer in the auxiliary scanning direction.</p> <ol style="list-style-type: none"> 3. Press the start key. The value is set. <p>Test copy mode While this maintenance item is being performed, a VTC pattern shown below is output in test copy mode. Correct values for an A4/8¹/₂" × 11" output are: Ⓐ = 260 ± 2.6 mm Ⓑ = 180 ± 1.8 mm</p> <div data-bbox="767 1144 948 1346" style="text-align: center;"> </div> <p>Figure 1-4-1</p> <p>Adjustment</p> <ol style="list-style-type: none"> 1. Press the size select key. The machine enters the test copy mode. 2. Press the start key. Output an A4/8¹/₂" × 11" VTC pattern. 3. Measure Ⓐ and Ⓑ on the VTC pattern (Figure 1-4-1), and perform the following adjustments if they are different from the correct sizes: Ⓐ: Drive motor speed adjustment Ⓑ: Polygon motor speed adjustment <p>Completion Press the stop/reset key at the screen for selecting an item. The indication for selecting a maintenance item No. appears.</p>	Copy exposure indicator	Description	Setting range	Initial setting	Exp. 1	Drive motor speed adjustment	-7.0 to +7.0	0	Exp. 3	Polygon motor speed adjustment	-5.0 to +2.0	0
Copy exposure indicator	Description	Setting range	Initial setting										
Exp. 1	Drive motor speed adjustment	-7.0 to +7.0	0										
Exp. 3	Polygon motor speed adjustment	-5.0 to +2.0	0										

Maintenance item No.	Description								
<p>U060</p>	<p>Adjusting the scanner input properties</p> <p>Description Adjusts the image scanning density.</p> <p>Purpose Used when the entire image appears too dark or light.</p> <p>Method Press the start key.</p> <p>Setting</p> <ol style="list-style-type: none"> Change the setting using the zoom +/- keys. <table border="1" data-bbox="304 548 1366 633"> <thead> <tr> <th>Description</th> <th>Setting range</th> <th>Initial setting</th> </tr> </thead> <tbody> <tr> <td>Image scanning density</td> <td>0 to 23</td> <td>12</td> </tr> </tbody> </table> <p>Increasing the setting makes the density lower, and decreasing it makes the density higher.</p> <ol style="list-style-type: none"> Press the start key. The value is set. <p>Test copy mode While this maintenance item is being performed, copying from an original can be made in test copy mode.</p> <p>Completion Press the stop/reset key at the screen for selecting an item. The indication for selecting a maintenance item No. appears.</p> <p>Caution The following settings are also reset to the initial values by performing this maintenance item:</p> <ul style="list-style-type: none"> Exposure density gradient set in maintenance mode (U093) Exposure set in the copy default item of the copier management mode 	Description	Setting range	Initial setting	Image scanning density	0 to 23	12		
Description	Setting range	Initial setting							
Image scanning density	0 to 23	12							
<p>U061</p>	<p>Turning the exposure lamp on</p> <p>Description Turns the exposure lamp on.</p> <p>Purpose To check the exposure lamp.</p> <p>Method</p> <ol style="list-style-type: none"> Press the start key. "on" appears. Press the start key. The exposure lamp lights. To turn the exposure lamp off, press the stop/reset key. <p>Completion Press the stop/reset key. The indication for selecting a maintenance item No. appears.</p>								
<p>U063</p>	<p>Adjusting the shading position</p> <p>Description Changes the shading position.</p> <p>Purpose Used when white lines continue to appear longitudinally on the image after the shading plate is cleaned. This is due to flaws or stains inside the shading plate. To prevent this problem, the shading position should be changed so that shading is possible without being affected by the flaws or stains.</p> <p>Method</p> <ol style="list-style-type: none"> Press the start key. Change the setting using the zoom +/- keys. <table border="1" data-bbox="304 1668 1366 1753"> <thead> <tr> <th>Description</th> <th>Setting range</th> <th>Initial setting</th> <th>Change in value per step</th> </tr> </thead> <tbody> <tr> <td>Shading position</td> <td>-15 to +15</td> <td>0</td> <td>0.254 mm</td> </tr> </tbody> </table> <p>Increasing the setting moves the shading position toward the machine right, and decreasing it moves the position toward the machine left.</p> <ol style="list-style-type: none"> Press the start key. The value is set. <p>Test copy mode While this maintenance item is being performed, copying from an original can be made in test copy mode.</p> <p>Completion Press the stop/reset key at the screen for adjustment. The indication for selecting a maintenance item No. appears.</p>	Description	Setting range	Initial setting	Change in value per step	Shading position	-15 to +15	0	0.254 mm
Description	Setting range	Initial setting	Change in value per step						
Shading position	-15 to +15	0	0.254 mm						





































Maintenance item No.	Description																																
U065	<p>Adjusting the scanner magnification</p> <p>Adjustment See pages 1-6-22 and 23.</p>																																
U066	<p>Adjusting the leading edge registration for scanning an original on the contact glass</p> <p>Adjustment See page 1-6-24.</p>																																
U067	<p>Adjusting the center line for scanning an original on the contact glass</p> <p>Adjustment See page 1-6-25.</p>																																
U073	<p>Checking scanner operation</p> <p>Description Simulates the scanner operation under arbitrary conditions.</p> <p>Purpose To check scanner operation.</p> <p>Method</p> <ol style="list-style-type: none"> 1. Press the start key. 2. Select the item to be changed by lighting a copy exposure indicator using the copy exposure adjustment keys. 3. Change the setting using the zoom +/- keys. <table border="1" data-bbox="316 882 1378 1021"> <thead> <tr> <th>Copy exposure indicator</th> <th>Operating conditions</th> <th>Setting range</th> </tr> </thead> <tbody> <tr> <td>Exp. 1</td> <td>Magnification</td> <td>50 to 200%</td> </tr> <tr> <td>Exp. 3</td> <td>Paper size</td> <td>See below.</td> </tr> <tr> <td>Exp. 5</td> <td>On and off of the exposure lamp</td> <td>on or off</td> </tr> </tbody> </table> <p>Paper size for each setting</p> <table border="1" data-bbox="316 1093 1378 1254"> <thead> <tr> <th>Setting</th> <th>Paper size</th> <th>Setting</th> <th>Paper size</th> </tr> </thead> <tbody> <tr> <td>9</td> <td>B5</td> <td>47</td> <td>Folio</td> </tr> <tr> <td>40</td> <td>A4R</td> <td>55</td> <td>8 1/2" × 14"</td> </tr> <tr> <td>41</td> <td>B5R</td> <td>56</td> <td>8 1/2" × 11"R</td> </tr> <tr> <td>42</td> <td>A5R</td> <td>58</td> <td>5 1/2" × 8 1/2"R</td> </tr> </tbody> </table> <ol style="list-style-type: none"> 4. Press the size select key. Scanning starts under the selected conditions. 5. To stop operation, press the stop/reset key. <p>Completion Press the stop/reset key when scanning stops. The indication for selecting a maintenance item No. appears.</p>	Copy exposure indicator	Operating conditions	Setting range	Exp. 1	Magnification	50 to 200%	Exp. 3	Paper size	See below.	Exp. 5	On and off of the exposure lamp	on or off	Setting	Paper size	Setting	Paper size	9	B5	47	Folio	40	A4R	55	8 1/2" × 14"	41	B5R	56	8 1/2" × 11"R	42	A5R	58	5 1/2" × 8 1/2"R
Copy exposure indicator	Operating conditions	Setting range																															
Exp. 1	Magnification	50 to 200%																															
Exp. 3	Paper size	See below.																															
Exp. 5	On and off of the exposure lamp	on or off																															
Setting	Paper size	Setting	Paper size																														
9	B5	47	Folio																														
40	A4R	55	8 1/2" × 14"																														
41	B5R	56	8 1/2" × 11"R																														
42	A5R	58	5 1/2" × 8 1/2"R																														

Maintenance item No.	Description																
<p>U088</p>	<p>Setting the input filter (moiré reduction mode)</p> <p>Description Turns moiré reduction mode on and off by switching the input filter on and off.</p> <p>Purpose Used to prevent regular density unevenness (moiré) on halftone image areas of the copy image in text mode and text and photo mode. Such moiré is more likely to appear when an enlargement or reduction copy is made in text mode from an original containing large halftone image areas.</p> <p>Method Press the start key.</p> <p>Setting</p> <ol style="list-style-type: none"> Select "on" or "oFF" using the zoom +/- keys. <table border="1" data-bbox="304 607 1366 719"> <thead> <tr> <th>Display</th> <th>Description</th> </tr> </thead> <tbody> <tr> <td>on</td> <td>Moiré reduction mode</td> </tr> <tr> <td>oFF</td> <td>Normal copy mode</td> </tr> </tbody> </table> <p>Initial setting: oFF</p> <p>If moiré on the copy image is significant, change the setting to "on". Note that when the moiré reduction mode is turned on, the resolution may be slightly reduced.</p> <ol style="list-style-type: none"> Press the start key. The value is set. The indication for selecting a maintenance item No. appears. <p>Completion To exit this maintenance item without changing the current setting, press the stop/reset key. The indication for selecting a maintenance item No. appears.</p>	Display	Description	on	Moiré reduction mode	oFF	Normal copy mode										
Display	Description																
on	Moiré reduction mode																
oFF	Normal copy mode																
<p>U089</p>	<p>Outputting a MIP-PG pattern</p> <p>Description Selects and outputs a MIP-PG pattern created in the copier.</p> <p>Purpose When performing respective image printing adjustments, used to check the machine status apart from that of the scanner with a non-scanned output MIP-PG pattern.</p> <p>Method</p> <ol style="list-style-type: none"> Press the start key. Select the MIP-PG pattern to be output using the copy exposure adjustment keys. <table border="1" data-bbox="304 1245 1366 1379"> <thead> <tr> <th>Display</th> <th>Setting</th> <th>Setting range</th> <th>Initial setting</th> </tr> </thead> <tbody> <tr> <td>G-5</td> <td>Gray scale</td> <td>-</td> <td>-</td> </tr> <tr> <td>180</td> <td>Mono level</td> <td>0 to 255</td> <td>180</td> </tr> <tr> <td>1-d</td> <td>1-dot level</td> <td>-</td> <td>-</td> </tr> </tbody> </table> <ol style="list-style-type: none"> Press the size select key. The machine enters the PG pattern output mode. Press the start key. A MIP-PG pattern is output. <p>Completion Press the stop/reset key. The indication for selecting a maintenance item No. appears.</p>	Display	Setting	Setting range	Initial setting	G-5	Gray scale	-	-	180	Mono level	0 to 255	180	1-d	1-dot level	-	-
Display	Setting	Setting range	Initial setting														
G-5	Gray scale	-	-														
180	Mono level	0 to 255	180														
1-d	1-dot level	-	-														

























Maintenance item No.	Description																														
<p>U091</p>	<p>Checking shading</p> <p>Description Performs scanning under the same conditions as before and after shading is performed, displaying the original scanning values at nine points of the contact glass.</p> <p>Purpose To check the change in original scanning values before and after shading. The results may be used to decide the causes for fixing unevenness (uneven density) of the gray area of an image: either due to optical (shading or CCD) or other problems. Also to check the causes for a white or black line appearing longitudinally.</p> <p>Method</p> <ol style="list-style-type: none"> 1. Press the start key. A selection item appears. 2. Select the item to be operated using the zoom +/- keys. <table border="1" data-bbox="320 633 1382 745"> <thead> <tr> <th>Display</th> <th>Output list</th> </tr> </thead> <tbody> <tr> <td>on</td> <td>Performs scanning before shading and displays the result.</td> </tr> <tr> <td>oFF</td> <td>Performs scanning after shading and displays the result.</td> </tr> </tbody> </table> <ol style="list-style-type: none"> 3. Press the start key. Scanning is performed under the selected conditions and the result is displayed. 4. Change the measurement point by lighting a copy exposure indicator or making one flash using the copy exposure adjustment keys. For the correspondence between the measurement points and the copy exposure indicators, see Figure 1-4-2. <div data-bbox="555 913 1166 1155" style="text-align: center;"> </div> <table border="1" data-bbox="395 1189 1203 1832"> <thead> <tr> <th>Point</th> <th>Copy exposure indicator</th> <th>Point</th> <th>Copy exposure indicator</th> </tr> </thead> <tbody> <tr> <td>①</td> <td>● ○ ○ ○ ○ exp.1 exp.3 exp.5</td> <td>⑥</td> <td>○ ○ ○ ○ ☼ exp.1 exp.3 exp.5</td> </tr> <tr> <td>②</td> <td>○ ○ ● ○ ○ exp.1 exp.3 exp.5</td> <td>⑦</td> <td>☼ ○ ○ ○ ○ exp.1 exp.3 exp.5</td> </tr> <tr> <td>③</td> <td>○ ○ ○ ○ ● exp.1 exp.3 exp.5</td> <td>⑧</td> <td>○ ○ ☼ ○ ○ exp.1 exp.3 exp.5</td> </tr> <tr> <td>④</td> <td>☼ ○ ○ ○ ○ exp.1 exp.3 exp.5</td> <td>⑨</td> <td>○ ○ ○ ○ ☼ exp.1 exp.3 exp.5</td> </tr> <tr> <td>⑤</td> <td>○ ○ ☼ ○ ○ exp.1 exp.3 exp.5</td> <td></td> <td>○ : Off ● : On ☼ : Flashing</td> </tr> </tbody> </table>	Display	Output list	on	Performs scanning before shading and displays the result.	oFF	Performs scanning after shading and displays the result.	Point	Copy exposure indicator	Point	Copy exposure indicator	①	● ○ ○ ○ ○ exp.1 exp.3 exp.5	⑥	○ ○ ○ ○ ☼ exp.1 exp.3 exp.5	②	○ ○ ● ○ ○ exp.1 exp.3 exp.5	⑦	☼ ○ ○ ○ ○ exp.1 exp.3 exp.5	③	○ ○ ○ ○ ● exp.1 exp.3 exp.5	⑧	○ ○ ☼ ○ ○ exp.1 exp.3 exp.5	④	☼ ○ ○ ○ ○ exp.1 exp.3 exp.5	⑨	○ ○ ○ ○ ☼ exp.1 exp.3 exp.5	⑤	○ ○ ☼ ○ ○ exp.1 exp.3 exp.5		○ : Off ● : On ☼ : Flashing
Display	Output list																														
on	Performs scanning before shading and displays the result.																														
oFF	Performs scanning after shading and displays the result.																														
Point	Copy exposure indicator	Point	Copy exposure indicator																												
①	● ○ ○ ○ ○ exp.1 exp.3 exp.5	⑥	○ ○ ○ ○ ☼ exp.1 exp.3 exp.5																												
②	○ ○ ● ○ ○ exp.1 exp.3 exp.5	⑦	☼ ○ ○ ○ ○ exp.1 exp.3 exp.5																												
③	○ ○ ○ ○ ● exp.1 exp.3 exp.5	⑧	○ ○ ☼ ○ ○ exp.1 exp.3 exp.5																												
④	☼ ○ ○ ○ ○ exp.1 exp.3 exp.5	⑨	○ ○ ○ ○ ☼ exp.1 exp.3 exp.5																												
⑤	○ ○ ☼ ○ ○ exp.1 exp.3 exp.5		○ : Off ● : On ☼ : Flashing																												

Figure 1-4-2

Maintenance item No.	Description								
<p>U091 (cont.)</p>	<p>When scanning is performed before shading, the scan value at the machine center should be slightly different from those at the machine front and rear. When scanning is performed after shading, there should be no difference between respective values. Any differences between the values at machine front and rear indicates that scanner problem causes the fixing unevenness.</p> <p>If the displayed results indicate no shading problems, the fixing unevenness (uneven copy density) is caused by factors other than in the scanner section (shading or CCD).</p> <p>If a black line appears, the cause may be assumed based on the results of the scanning operation before shading: if a white line appears, they may be assumed based on the results of the scanning operation after shading. Note that depending on the thickness and location of the black or white line, it may not be possible to use this method to determine the cause. This is because the displayed values obtained from scanning at the limit of nine points are insufficient to provide significant information.</p> <p>5. Press the stop/reset key. The selected item appears.</p> <p>Completion Press the stop/reset key while a selection item is displayed. The indication for selecting a maintenance item No. appears.</p>								
<p>U092</p>	<p>Adjusting the scanner automatically</p> <p>Description Makes auto scanner adjustments in the order below using the specified original.</p> <ul style="list-style-type: none"> • Adjusting the scanner center line (U067) • Adjusting the scanner leading edge registration (U066) • Adjusting scanner magnification in the auxiliary direction (U065) <p>When this maintenance item is performed, the settings in U065, U066 and U067 are also changed.</p> <p>Purpose Used to make respective auto adjustments for the scanner.</p> <p>Method</p> <ol style="list-style-type: none"> 1. Place the specified original (P/N: 2A168070) on the contact glass. 2. Press the start key. "on" appears. 3. Press the start key. Auto adjustment starts. When adjustment is complete, "Gd" appears. 4. Display each setting value after adjustment by lighting a copy exposure indicator using the copy exposure adjustment keys. <table border="1" data-bbox="304 1205 1366 1346"> <thead> <tr> <th>Copy exposure indicator</th> <th>Setting value</th> </tr> </thead> <tbody> <tr> <td>Exp. 3</td> <td>Scanner center line</td> </tr> <tr> <td>Exp. 5</td> <td>Scanner leading edge registration</td> </tr> <tr> <td>Exp. 1 (flashing)</td> <td>Scanner magnification in the auxiliary scanning direction</td> </tr> </tbody> </table> <p>If a problem occurs during auto adjustment, "nG" is displayed and operation stops. Lighting the copy exposure indicator exp. 3 and then exp. 5 using the copy exposure adjustment keys will display the error code. Determine the details of the problem and either repeat the procedure from the beginning, or adjust the remaining items manually by running the corresponding maintenance items.</p> <p>Completion Press the stop/reset key after auto adjustment is complete. The indication for selecting a maintenance item No. appears. If the stop/reset key is pressed during auto adjustment, adjustment stops and no settings are changed.</p>	Copy exposure indicator	Setting value	Exp. 3	Scanner center line	Exp. 5	Scanner leading edge registration	Exp. 1 (flashing)	Scanner magnification in the auxiliary scanning direction
Copy exposure indicator	Setting value								
Exp. 3	Scanner center line								
Exp. 5	Scanner leading edge registration								
Exp. 1 (flashing)	Scanner magnification in the auxiliary scanning direction								

Maintenance item No.	Description												
<p>U093</p>	<p>Setting the exposure density gradient</p> <p>Description Changes the exposure density gradient in manual density mode, depending on respective image modes (text, text and photo, photo).</p> <p>Purpose To set how the image density is altered by a change of one step in the manual density adjustment. Also used to make copy image darker or lighter.</p> <p>Start</p> <ol style="list-style-type: none"> 1. Press the start key. A selection item appears. 2. Select the image mode to be adjusted by lighting image mode LEDs using the image mode selection key. 3. Press the start key. The machine enters the setting mode. <table border="1" data-bbox="320 600 1382 1021"> <thead> <tr> <th data-bbox="320 600 480 645">Image mode LEDs</th> <th data-bbox="480 600 644 645"></th> <th data-bbox="644 600 1382 645">Description</th> </tr> </thead> <tbody> <tr> <td data-bbox="320 645 480 770"> <input type="radio"/>  <input type="radio"/>  <input type="radio"/>  <input checked="" type="radio"/>  </td> <td data-bbox="480 645 644 770"> <input type="radio"/> AutoExp. <input type="radio"/> Text & Photo <input type="radio"/> Photo <input checked="" type="radio"/> Text </td> <td data-bbox="644 645 1382 770">Density in text mode</td> </tr> <tr> <td data-bbox="320 770 480 896"> <input type="radio"/>  <input type="radio"/>  <input checked="" type="radio"/>  <input checked="" type="radio"/>  </td> <td data-bbox="480 770 644 896"> <input type="radio"/> AutoExp. <input type="radio"/> Text & Photo <input checked="" type="radio"/> Photo <input checked="" type="radio"/> Text </td> <td data-bbox="644 770 1382 896">Density in text and photo mode</td> </tr> <tr> <td data-bbox="320 896 480 1021"> <input type="radio"/>  <input checked="" type="radio"/>  <input checked="" type="radio"/>  <input checked="" type="radio"/>  </td> <td data-bbox="480 896 644 1021"> <input type="radio"/> AutoExp. <input checked="" type="radio"/> Text & Photo <input checked="" type="radio"/> Photo <input checked="" type="radio"/> Text </td> <td data-bbox="644 896 1382 1021">Density in photo mode</td> </tr> </tbody> </table> <p>○ : Off, ● : On</p>	Image mode LEDs		Description	<input type="radio"/>  <input type="radio"/>  <input type="radio"/>  <input checked="" type="radio"/> 	<input type="radio"/> AutoExp. <input type="radio"/> Text & Photo <input type="radio"/> Photo <input checked="" type="radio"/> Text	Density in text mode	<input type="radio"/>  <input type="radio"/>  <input checked="" type="radio"/>  <input checked="" type="radio"/> 	<input type="radio"/> AutoExp. <input type="radio"/> Text & Photo <input checked="" type="radio"/> Photo <input checked="" type="radio"/> Text	Density in text and photo mode	<input type="radio"/>  <input checked="" type="radio"/>  <input checked="" type="radio"/>  <input checked="" type="radio"/> 	<input type="radio"/> AutoExp. <input checked="" type="radio"/> Text & Photo <input checked="" type="radio"/> Photo <input checked="" type="radio"/> Text	Density in photo mode
Image mode LEDs		Description											
<input type="radio"/>  <input type="radio"/>  <input type="radio"/>  <input checked="" type="radio"/> 	<input type="radio"/> AutoExp. <input type="radio"/> Text & Photo <input type="radio"/> Photo <input checked="" type="radio"/> Text	Density in text mode											
<input type="radio"/>  <input type="radio"/>  <input checked="" type="radio"/>  <input checked="" type="radio"/> 	<input type="radio"/> AutoExp. <input type="radio"/> Text & Photo <input checked="" type="radio"/> Photo <input checked="" type="radio"/> Text	Density in text and photo mode											
<input type="radio"/>  <input checked="" type="radio"/>  <input checked="" type="radio"/>  <input checked="" type="radio"/> 	<input type="radio"/> AutoExp. <input checked="" type="radio"/> Text & Photo <input checked="" type="radio"/> Photo <input checked="" type="radio"/> Text	Density in photo mode											

Maintenance item No.	Description		
U093 (cont.) Setting 1. Select the item to be adjusted by lighting a copy exposure indicator using the copy exposure adjustment keys. 2. Adjust the setting using the zoom +/- keys.			
Copy exposure indicator	Description	Setting range	Initial setting
Exp. 1 Exp. 3	Change in density when manual density is set dark Change in density when manual density is set light	0 to 3 0 to 3	0 0
Increasing the setting makes the change in density larger, and decreasing it makes the change smaller.			
<p align="center">Figure 1-4-3 Exposure density gradient</p>			
3. Press the start key. The value is set. 4. Press the stop/reset key. The selected item appears.			
Test copy mode While this maintenance item is being performed, copying from an original can be made in test copy mode.			
Completion Press the stop/reset key while a selection item is displayed. The indication for selecting a maintenance item No. appears.			

Maintenance item No.	Description																					
U100	<p>Setting the surface potential</p> <p>Description Changes the surface potential by changing the grid control voltage. Also performs main charging.</p> <p>Purpose To set the surface potential or check main charging. Also used when reentering data after initializing the set data.</p> <p>Start</p> <ol style="list-style-type: none"> 1. Press the start key. A selection item appears. 2. Select the item by lighting image mode LEDs using the image mode selection key. <table border="1" data-bbox="320 539 1382 837"> <thead> <tr> <th data-bbox="320 539 480 584">Image mode LEDs</th> <th data-bbox="480 539 644 584">Description</th> <th data-bbox="644 539 1382 584">Description</th> </tr> </thead> <tbody> <tr> <td data-bbox="320 584 480 712"> <input type="radio"/>  <input type="radio"/>  <input type="radio"/>  <input checked="" type="radio"/>  </td> <td data-bbox="480 584 644 712"> <input type="radio"/> AutoExp. <input type="radio"/> Text & Photo <input type="radio"/> Photo <input checked="" type="radio"/> Text </td> <td data-bbox="644 584 1382 712">Setting the developing bias</td> </tr> <tr> <td data-bbox="320 712 480 837"> <input type="radio"/>  <input type="radio"/>  <input checked="" type="radio"/>  <input checked="" type="radio"/>  </td> <td data-bbox="480 712 644 837"> <input type="radio"/> AutoExp. <input type="radio"/> Text & Photo <input checked="" type="radio"/> Photo <input checked="" type="radio"/> Text </td> <td data-bbox="644 712 1382 837">Setting and checking the transfer voltage</td> </tr> </tbody> </table> <p>○ : Off, ● : On</p> <p>Method for main charger output</p> <ol style="list-style-type: none"> 1. Select the item using the copy exposure adjustment keys. <table border="1" data-bbox="320 943 1382 1081"> <thead> <tr> <th data-bbox="320 943 730 987">Display (copy exposure indicator)</th> <th data-bbox="730 943 1382 987">Description</th> </tr> </thead> <tbody> <tr> <td data-bbox="320 987 730 1025">on1 (exp. 1)</td> <td data-bbox="730 987 1382 1025">Turning the main charger on</td> </tr> <tr> <td data-bbox="320 1025 730 1081">on2 (exp. 3)</td> <td data-bbox="730 1025 1382 1081">Turning the main charger on and the laser scanner unit on and off</td> </tr> </tbody> </table> <ol style="list-style-type: none"> 2. Press the start key. The selected operation starts. 3. To stop operation, press the stop/reset key. <p>Setting the grid control voltage</p> <ol style="list-style-type: none"> 1. Change the setting using the zoom +/- keys. <table border="1" data-bbox="320 1223 1382 1301"> <thead> <tr> <th data-bbox="320 1223 831 1267">Description</th> <th data-bbox="831 1223 1139 1267">Setting range</th> <th data-bbox="1139 1223 1382 1267">Initial setting</th> </tr> </thead> <tbody> <tr> <td data-bbox="320 1267 831 1301">Grid control voltage</td> <td data-bbox="831 1267 1139 1301">0 to 255</td> <td data-bbox="1139 1267 1382 1301">197</td> </tr> </tbody> </table> <p>Increasing the setting makes the surface potential higher, and decreasing it makes the potential lower. Change in value per step: approximately 3.6 V</p> <ol style="list-style-type: none"> 2. Press the start key. The value is set. <p>Test copy mode While this maintenance item is being performed, copying from an original can be made in test copy mode.</p> <p>Completion Press the stop/reset key when main charger output stops while a selection item is displayed. The indication for selecting a maintenance item No. appears.</p>	Image mode LEDs	Description	Description	<input type="radio"/>  <input type="radio"/>  <input type="radio"/>  <input checked="" type="radio"/> 	<input type="radio"/> AutoExp. <input type="radio"/> Text & Photo <input type="radio"/> Photo <input checked="" type="radio"/> Text	Setting the developing bias	<input type="radio"/>  <input type="radio"/>  <input checked="" type="radio"/>  <input checked="" type="radio"/> 	<input type="radio"/> AutoExp. <input type="radio"/> Text & Photo <input checked="" type="radio"/> Photo <input checked="" type="radio"/> Text	Setting and checking the transfer voltage	Display (copy exposure indicator)	Description	on1 (exp. 1)	Turning the main charger on	on2 (exp. 3)	Turning the main charger on and the laser scanner unit on and off	Description	Setting range	Initial setting	Grid control voltage	0 to 255	197
Image mode LEDs	Description	Description																				
<input type="radio"/>  <input type="radio"/>  <input type="radio"/>  <input checked="" type="radio"/> 	<input type="radio"/> AutoExp. <input type="radio"/> Text & Photo <input type="radio"/> Photo <input checked="" type="radio"/> Text	Setting the developing bias																				
<input type="radio"/>  <input type="radio"/>  <input checked="" type="radio"/>  <input checked="" type="radio"/> 	<input type="radio"/> AutoExp. <input type="radio"/> Text & Photo <input checked="" type="radio"/> Photo <input checked="" type="radio"/> Text	Setting and checking the transfer voltage																				
Display (copy exposure indicator)	Description																					
on1 (exp. 1)	Turning the main charger on																					
on2 (exp. 3)	Turning the main charger on and the laser scanner unit on and off																					
Description	Setting range	Initial setting																				
Grid control voltage	0 to 255	197																				

Maintenance item No.	Description																																									
U101	<p>Setting high voltages</p> <p>Description Changes the developing bias voltage and transfer voltage by changing the developing bias control voltage and transfer control voltage. Also checks the transfer output voltage.</p> <p>Purpose To check and change high voltages other than the main charger voltage.</p> <p>Start</p> <ol style="list-style-type: none"> 1. Press the start key. A selection item appears. 2. Select the item to be set or checked by lighting image mode LEDs using the image mode selection key. <table border="1" style="width: 100%; border-collapse: collapse;"> <thead> <tr> <th style="width: 30%;">Image mode LEDs</th> <th style="width: 30%;">Description</th> <th style="width: 40%;"></th> </tr> </thead> <tbody> <tr> <td> <input type="radio"/> <input type="radio"/> <input type="radio"/> <input checked="" type="radio"/> </td> <td> <input type="radio"/> AutoExp. <input type="radio"/> Text & Photo <input type="radio"/> Photo <input checked="" type="radio"/> Text </td> <td>Setting the developing bias</td> </tr> <tr> <td> <input type="radio"/> <input type="radio"/> <input checked="" type="radio"/> <input checked="" type="radio"/> </td> <td> <input type="radio"/> AutoExp. <input type="radio"/> Text & Photo <input checked="" type="radio"/> Photo <input checked="" type="radio"/> Text </td> <td>Setting and checking the transfer voltage</td> </tr> </tbody> </table> <p>○ : Off, ● : On</p> <p>Setting the developing bias</p> <ol style="list-style-type: none"> 1. Select the item to be adjusted by lighting a copy exposure indicator using the copy exposure adjustment keys. 2. Change the setting using the zoom +/- keys. <table border="1" style="width: 100%; border-collapse: collapse;"> <thead> <tr> <th style="width: 25%;">Copy exposure indicator</th> <th style="width: 40%;">Description</th> <th style="width: 15%;">Setting range</th> <th style="width: 20%;">Initial setting</th> </tr> </thead> <tbody> <tr> <td>Exp. 1</td> <td>Developing bias control voltage during image formation</td> <td>0 to 255</td> <td>200</td> </tr> <tr> <td>Exp. 3</td> <td>Developing bias control voltage during no image formation</td> <td>0 to 255</td> <td>34</td> </tr> </tbody> </table> <p>Increasing the setting makes the developing bias higher and the image darker; decreasing it makes the bias lower and the image lighter.</p> <ol style="list-style-type: none"> 3. Press the start key. The value is set. <p>Setting the transfer voltage</p> <ol style="list-style-type: none"> 1. Select the item to be adjusted by lighting a copy exposure indicator using the copy exposure adjustment keys. 2. Change the setting using the zoom +/- keys. <table border="1" style="width: 100%; border-collapse: collapse;"> <thead> <tr> <th style="width: 25%;">Copy exposure indicator</th> <th style="width: 40%;">Description</th> <th style="width: 15%;">Setting range</th> <th style="width: 20%;">Initial setting</th> </tr> </thead> <tbody> <tr> <td>Exp. 1</td> <td>Transfer control voltage</td> <td>0 to 255</td> <td>94</td> </tr> <tr> <td>Exp. 3 (on)</td> <td>Turning the transfer voltage output on</td> <td>–</td> <td>–</td> </tr> <tr> <td>Exp. 5</td> <td>Timing at which the transfer voltage output turns on</td> <td>160 to 360</td> <td>256</td> </tr> <tr> <td>Exp. 1 (flashing)</td> <td>Timing at which the transfer voltage output turns off timing</td> <td>450 to 650</td> <td>544</td> </tr> </tbody> </table> <p>Increasing the exp. 1 setting makes the transfer voltage higher, and decreasing it makes the voltage lower. Increasing the exp. 5 setting makes the transfer voltage output timing later and improves paper separation performance.</p> <ol style="list-style-type: none"> 3. Press the start key. The value is set. 4. To check the transfer voltage output, light the copy exposure indicator exp. 3 using the copy exposure adjustment keys and press the start key. The currently set transfer voltage is output. 5. To stop the transfer voltage output, press the stop/reset key. <p>Test copy mode While this maintenance item is being performed, copying from an original can be made in test copy mode.</p> <p>Completion Press the stop/reset key while a selection item is displayed. The indication for selecting a maintenance item No. appears.</p>	Image mode LEDs	Description		<input type="radio"/> <input type="radio"/> <input type="radio"/> <input checked="" type="radio"/>	<input type="radio"/> AutoExp. <input type="radio"/> Text & Photo <input type="radio"/> Photo <input checked="" type="radio"/> Text	Setting the developing bias	<input type="radio"/> <input type="radio"/> <input checked="" type="radio"/> <input checked="" type="radio"/>	<input type="radio"/> AutoExp. <input type="radio"/> Text & Photo <input checked="" type="radio"/> Photo <input checked="" type="radio"/> Text	Setting and checking the transfer voltage	Copy exposure indicator	Description	Setting range	Initial setting	Exp. 1	Developing bias control voltage during image formation	0 to 255	200	Exp. 3	Developing bias control voltage during no image formation	0 to 255	34	Copy exposure indicator	Description	Setting range	Initial setting	Exp. 1	Transfer control voltage	0 to 255	94	Exp. 3 (on)	Turning the transfer voltage output on	–	–	Exp. 5	Timing at which the transfer voltage output turns on	160 to 360	256	Exp. 1 (flashing)	Timing at which the transfer voltage output turns off timing	450 to 650	544
Image mode LEDs	Description																																									
<input type="radio"/> <input type="radio"/> <input type="radio"/> <input checked="" type="radio"/>	<input type="radio"/> AutoExp. <input type="radio"/> Text & Photo <input type="radio"/> Photo <input checked="" type="radio"/> Text	Setting the developing bias																																								
<input type="radio"/> <input type="radio"/> <input checked="" type="radio"/> <input checked="" type="radio"/>	<input type="radio"/> AutoExp. <input type="radio"/> Text & Photo <input checked="" type="radio"/> Photo <input checked="" type="radio"/> Text	Setting and checking the transfer voltage																																								
Copy exposure indicator	Description	Setting range	Initial setting																																							
Exp. 1	Developing bias control voltage during image formation	0 to 255	200																																							
Exp. 3	Developing bias control voltage during no image formation	0 to 255	34																																							
Copy exposure indicator	Description	Setting range	Initial setting																																							
Exp. 1	Transfer control voltage	0 to 255	94																																							
Exp. 3 (on)	Turning the transfer voltage output on	–	–																																							
Exp. 5	Timing at which the transfer voltage output turns on	160 to 360	256																																							
Exp. 1 (flashing)	Timing at which the transfer voltage output turns off timing	450 to 650	544																																							

Maintenance item No.	Description																
<p>U109</p>	<p>Setting the drum type</p> <p>Description Sets the type of the drum installed in the copier.</p> <p>Purpose To prevent variations in halftone due to differences in drum sensitivity.</p> <p>Method Press the start key.</p> <p>Setting 1. Select the drum type using the zoom +/- keys.</p> <table border="1" data-bbox="320 551 1382 723"> <thead> <tr> <th>Display</th> <th>Description</th> </tr> </thead> <tbody> <tr> <td>A</td> <td>Type A</td> </tr> <tr> <td>b</td> <td>Type b</td> </tr> <tr> <td>C</td> <td>Type C</td> </tr> <tr> <td>d</td> <td>Type d</td> </tr> </tbody> </table> <p>Initial setting: b</p> <p>2. Press the start key. The setting is set. The indication for selecting a maintenance item No. appears.</p> <p>Completion To exit this maintenance item without changing the current setting, press the stop/reset key. The indication for selecting a maintenance item No. appears.</p>	Display	Description	A	Type A	b	Type b	C	Type C	d	Type d						
Display	Description																
A	Type A																
b	Type b																
C	Type C																
d	Type d																
<p>U110</p>	<p>Checking/clearing the drum count</p> <p>Description Displays the drum counts for checking, clearing or changing the figure, which is used as a reference when correcting the main charger potential output.</p> <p>Purpose To check the drum status. Also used to clear the count after replacing the drum during regular maintenance. Since the count was cleared before shipping, do not clear it when installing.</p> <p>Method 1. Press the start key. 2. Select the item by lighting a copy exposure indicator using the copy exposure adjustment keys.</p> <table border="1" data-bbox="320 1211 1382 1350"> <thead> <tr> <th>Copy exposure indicator</th> <th>Description</th> <th>Setting range</th> <th>Initial setting</th> </tr> </thead> <tbody> <tr> <td>Exp. 1</td> <td>First 3 digits</td> <td>000 to 999</td> <td>000</td> </tr> <tr> <td>Exp. 3</td> <td>Last 3 digits</td> <td>000 to 999</td> <td>000</td> </tr> <tr> <td>Exp. 5</td> <td>Clearing the count</td> <td>_____</td> <td>_____</td> </tr> </tbody> </table> <p>Clearing 1. Light exp. 5. 2. Press the start key. The count is cleared, and the indication for selecting a maintenance item No. appears.</p> <p>Setting 1. Change the count using the zoom +/- keys. 2. Press the start key. The count is set, and the indication for selecting a maintenance item No. appears.</p> <p>Completion To exit the maintenance mode without changing the count, press the stop/reset key. The indication for selecting a maintenance item No. appears.</p>	Copy exposure indicator	Description	Setting range	Initial setting	Exp. 1	First 3 digits	000 to 999	000	Exp. 3	Last 3 digits	000 to 999	000	Exp. 5	Clearing the count	_____	_____
Copy exposure indicator	Description	Setting range	Initial setting														
Exp. 1	First 3 digits	000 to 999	000														
Exp. 3	Last 3 digits	000 to 999	000														
Exp. 5	Clearing the count	_____	_____														

Maintenance item No.	Description																
<p>U111</p>	<p>Checking/clearing the drum drive time</p> <p>Description Displays the drum drive time for checking, clearing or changing a figure, which is used as a reference when correcting the high voltage based on time.</p> <p>Purpose To check the drum status. Also used to clear the drive time after replacing the drum.</p> <p>Method</p> <ol style="list-style-type: none"> 1. Press the start key. 2. Select the item by lighting a copy exposure indicator using the copy exposure adjustment keys. <table border="1" data-bbox="304 539 1366 680"> <thead> <tr> <th>Copy exposure indicator</th> <th>Description</th> <th>Setting range</th> <th>Initial setting</th> </tr> </thead> <tbody> <tr> <td>Exp. 1</td> <td>First 2 digits</td> <td>00 to 59 (min)</td> <td>00</td> </tr> <tr> <td>Exp. 3</td> <td>Last 3 digits</td> <td>000 to 999 (min)</td> <td>000</td> </tr> <tr> <td>Exp. 5</td> <td>Clearing the drive time</td> <td>_____</td> <td>_____</td> </tr> </tbody> </table> <p>Clearing</p> <ol style="list-style-type: none"> 1. Light exp. 5. 2. Press the start key. The time is cleared, and the indication for selecting a maintenance item No. appears. <p>Setting</p> <ol style="list-style-type: none"> 1. Change the drive time (in minutes) using the zoom +/- keys. 2. Press the start key. The time is set, and the indication for selecting a maintenance No. appears. <p>Completion To exit this maintenance item without changing the time, press the stop/reset key. The indication for selecting a maintenance item No. appears.</p>	Copy exposure indicator	Description	Setting range	Initial setting	Exp. 1	First 2 digits	00 to 59 (min)	00	Exp. 3	Last 3 digits	000 to 999 (min)	000	Exp. 5	Clearing the drive time	_____	_____
Copy exposure indicator	Description	Setting range	Initial setting														
Exp. 1	First 2 digits	00 to 59 (min)	00														
Exp. 3	Last 3 digits	000 to 999 (min)	000														
Exp. 5	Clearing the drive time	_____	_____														
<p>U130</p>	<p>Initial setting for the developer</p> <p>Description Automatically sets the toner sensor control voltage and toner feed start level for the installed developer.</p> <p>Purpose To set the initial settings for the developer when installing the machine or replacing the developer.</p> <p>Method</p> <ol style="list-style-type: none"> 1. Press the start key. 2. Press the start key. The initial settings for the developer is set, and the result is displayed. 3. Display the setting value for each item by lighting the respective copy exposure indicator using the copy exposure adjustment keys. <table border="1" data-bbox="304 1301 1366 1473"> <thead> <tr> <th>Copy exposure indicator</th> <th>Description</th> </tr> </thead> <tbody> <tr> <td>Exp. 1</td> <td>Toner sensor output value</td> </tr> <tr> <td>Exp. 3</td> <td>Toner sensor control voltage</td> </tr> <tr> <td>Exp. 5</td> <td>Toner feed start level</td> </tr> <tr> <td>Exp. 1 (flashing)</td> <td>Absolute humidity</td> </tr> </tbody> </table> <p>Supplement The following data is also renewed or cleared by performing this maintenance item:</p> <ul style="list-style-type: none"> • Renewing the toner sensor control voltage (U131) • Renewing the toner feed start level (U156) • Clearing the developing drive time (U157) • Clearing the developing count (U158) • Resetting the toner feed start level and toner empty detection <p>Completion After initial setting is complete, press the stop/reset key. The indication for selecting a maintenance item No. appears.</p>	Copy exposure indicator	Description	Exp. 1	Toner sensor output value	Exp. 3	Toner sensor control voltage	Exp. 5	Toner feed start level	Exp. 1 (flashing)	Absolute humidity						
Copy exposure indicator	Description																
Exp. 1	Toner sensor output value																
Exp. 3	Toner sensor control voltage																
Exp. 5	Toner feed start level																
Exp. 1 (flashing)	Absolute humidity																

Maintenance item No.	Description										
<p>U131</p>	<p>Setting the toner sensor control voltage</p> <p>Description Displays or changes the toner sensor control voltage automatically set in maintenance item U130.</p> <p>Purpose To check the automatically set toner sensor control voltage. Also to change the toner density if an image is too dark or light.</p> <p>Method Press the start key. The current setting for the toner sensor control voltage is displayed.</p> <p>Setting</p> <ol style="list-style-type: none"> 1. Change the setting using the zoom +/- keys. <table border="1" data-bbox="320 577 1382 663"> <thead> <tr> <th>Description</th> <th>Setting range</th> <th>Initial setting</th> </tr> </thead> <tbody> <tr> <td>Toner sensor control voltage</td> <td>0 to 255</td> <td>157</td> </tr> </tbody> </table> <p>Increasing the setting makes the density higher, and decreasing it makes the density lower. Increasing the setting too high may result in toner scattering.</p> <ol style="list-style-type: none"> 2. Press the start key. The value is set. <p>Completion Press the stop/reset key. The indication for selecting a maintenance item No. appears.</p>	Description	Setting range	Initial setting	Toner sensor control voltage	0 to 255	157				
Description	Setting range	Initial setting									
Toner sensor control voltage	0 to 255	157									
<p>U132</p>	<p>Replenishing toner forcibly</p> <p>Description Replenishes toner forcibly until the toner sensor output value reaches the toner feed start level.</p> <p>Purpose Used when the toner empty is detected frequently.</p> <p>Method</p> <ol style="list-style-type: none"> 1. Press the start key. 2. Press the start key. Operation starts, and the current data is displayed. Toner is replenished until the toner sensor output value reaches the toner feed start level. 3. Display each data by lighting the respective copy exposure indicator using the copy exposure adjustment keys. <table border="1" data-bbox="320 1178 1382 1350"> <thead> <tr> <th>Copy exposure indicator</th> <th>Description</th> </tr> </thead> <tbody> <tr> <td>Exp. 1</td> <td>Toner sensor output value after start key is pressed</td> </tr> <tr> <td>Exp. 3</td> <td>Current toner feed start level</td> </tr> <tr> <td>Exp. 5</td> <td>Current toner sensor control voltage</td> </tr> <tr> <td>Exp. 1 (flashing)</td> <td>Absolute humidity</td> </tr> </tbody> </table> <ol style="list-style-type: none"> 4. To stop operation, press the stop/reset key. <p>Completion Press the stop/reset key when toner replenishment stops. The indication for selecting a maintenance item No. appears.</p>	Copy exposure indicator	Description	Exp. 1	Toner sensor output value after start key is pressed	Exp. 3	Current toner feed start level	Exp. 5	Current toner sensor control voltage	Exp. 1 (flashing)	Absolute humidity
Copy exposure indicator	Description										
Exp. 1	Toner sensor output value after start key is pressed										
Exp. 3	Current toner feed start level										
Exp. 5	Current toner sensor control voltage										
Exp. 1 (flashing)	Absolute humidity										
<p>U135</p>	<p>Checking toner feed motor operation</p> <p>Description Drives the toner feed motor.</p> <p>Purpose To check the operation of the toner feed motor.</p> <p>Caution Note that driving the motor unnecessarily long may cause a toner jam, resulting in machine lockup. Be sure to drive the motor for only a few seconds.</p> <p>Method</p> <ol style="list-style-type: none"> 1. Press the start key. "on" appears. 2. Press the start key. The toner feed motor turns on. 3. To stop operation, press the stop/reset key. <p>Completion Press the stop/reset key when operation stops. The indication for selecting a maintenance item No. appears.</p>										

Maintenance item No.	Description																		
<p>U155</p>	<p>Displaying the toner sensor output</p> <p>Description Displays the toner sensor output value, and related data.</p> <p>Purpose To check the toner sensor output value.</p> <p>Method</p> <ol style="list-style-type: none"> 1. Press the start key. 2. Press the start key. Sampling starts. 3. Display each data by lighting the respective copy exposure indicator using the copy exposure adjustment keys. <table border="1" data-bbox="304 573 1366 770"> <thead> <tr> <th>Copy exposure indicator</th> <th>Description</th> </tr> </thead> <tbody> <tr> <td>Exp. 1</td> <td>Toner sensor output value after start key is pressed</td> </tr> <tr> <td>Exp. 3</td> <td>Current toner feed level (value corrected based on humidity and drive time)</td> </tr> <tr> <td>Exp. 5</td> <td>Current toner sensor control voltage</td> </tr> <tr> <td>Exp. 1 (flashing)</td> <td>Absolute humidity</td> </tr> </tbody> </table> <ol style="list-style-type: none"> 4. Press the stop/reset key. The sampling operation stops. <p>Completion Press the stop/reset key when operation stops. The indication for selecting a maintenance item No. appears.</p>	Copy exposure indicator	Description	Exp. 1	Toner sensor output value after start key is pressed	Exp. 3	Current toner feed level (value corrected based on humidity and drive time)	Exp. 5	Current toner sensor control voltage	Exp. 1 (flashing)	Absolute humidity								
Copy exposure indicator	Description																		
Exp. 1	Toner sensor output value after start key is pressed																		
Exp. 3	Current toner feed level (value corrected based on humidity and drive time)																		
Exp. 5	Current toner sensor control voltage																		
Exp. 1 (flashing)	Absolute humidity																		
<p>U156</p>	<p>Changing the toner control level</p> <p>Description Changes the toner feed start level set in maintenance item U130 or the toner empty level to be determined by the difference from the toner feed start level.</p> <p>Purpose To check the toner feed start level and toner empty level.</p> <p>Method</p> <ol style="list-style-type: none"> 1. Press the start key. 2. Select the item by lighting a copy exposure indicator using the copy exposure adjustment keys. <table border="1" data-bbox="304 1171 1366 1312"> <thead> <tr> <th>Copy exposure indicator</th> <th>Description</th> </tr> </thead> <tbody> <tr> <td>Exp. 1</td> <td>Toner feed start level</td> </tr> <tr> <td>Exp. 3</td> <td>Difference between the toner feed start level and toner empty level</td> </tr> </tbody> </table> <p>Setting for the toner feed start level</p> <ol style="list-style-type: none"> 1. Change the setting using the zoom +/- keys. <table border="1" data-bbox="304 1391 1366 1469"> <thead> <tr> <th>Description</th> <th>Setting range</th> <th>Initial setting</th> </tr> </thead> <tbody> <tr> <td>Toner feed start level</td> <td>0 to 255</td> <td>113</td> </tr> </tbody> </table> <p>Increasing the setting makes the toner density lower.</p> <ol style="list-style-type: none"> 2. Press the start key. The value is set. <p>Setting for the toner empty level</p> <ol style="list-style-type: none"> 1. Change the setting using the zoom +/- keys. <table border="1" data-bbox="304 1608 1366 1720"> <thead> <tr> <th>Description</th> <th>Setting range</th> <th>Initial setting</th> </tr> </thead> <tbody> <tr> <td>Difference between the toner feed start level and the toner empty level</td> <td>0 to 255</td> <td>44</td> </tr> </tbody> </table> <p>Increasing the setting makes the toner empty level higher: the toner density is lower when the toner empty is detected.</p> <ol style="list-style-type: none"> 2. Press the start key. The value is set. <p>Completion To exit this maintenance item without changing the current setting, press the stop/reset key. The indication for selecting a maintenance item No. appears.</p>	Copy exposure indicator	Description	Exp. 1	Toner feed start level	Exp. 3	Difference between the toner feed start level and toner empty level	Description	Setting range	Initial setting	Toner feed start level	0 to 255	113	Description	Setting range	Initial setting	Difference between the toner feed start level and the toner empty level	0 to 255	44
Copy exposure indicator	Description																		
Exp. 1	Toner feed start level																		
Exp. 3	Difference between the toner feed start level and toner empty level																		
Description	Setting range	Initial setting																	
Toner feed start level	0 to 255	113																	
Description	Setting range	Initial setting																	
Difference between the toner feed start level and the toner empty level	0 to 255	44																	

Maintenance item No.	Description																
U157	<p>Checking/clearing the developing drive time</p> <p>Description Displays the developing drive time for checking, clearing or changing a figure, which is used as a reference when correcting the toner control. It is automatically cleared when U130 is executed.</p> <p>Purpose To check the developing drive time after replacing the developer.</p> <p>Method</p> <ol style="list-style-type: none"> 1. Press the start key. 2. Select the item by lighting a copy exposure indicator using the copy exposure adjustment keys. <table border="1" data-bbox="320 544 1382 685"> <thead> <tr> <th>Copy exposure indicator</th> <th>Description</th> <th>Setting range</th> <th>Initial setting</th> </tr> </thead> <tbody> <tr> <td>Exp. 1</td> <td>First 2 digits</td> <td>00 to 59 (min)</td> <td>00</td> </tr> <tr> <td>Exp. 3</td> <td>Last 3 digits</td> <td>000 to 999 (min)</td> <td>000</td> </tr> <tr> <td>Exp. 5</td> <td>Clearing the drive time</td> <td>_____</td> <td>_____</td> </tr> </tbody> </table> <p>Clearing</p> <ol style="list-style-type: none"> 1. Light exp. 5. 2. Press the start key. The time is cleared, and the indication for selecting a maintenance item No. appears. <p>Setting</p> <ol style="list-style-type: none"> 1. Change the drive time (in minutes) using the zoom +/- keys. 2. Press the start key. The time is set, and the indication for selecting a maintenance item No. appears. <p>Completion To exit this maintenance item without changing the time, press the stop/reset key. The indication for selecting a maintenance item No. appears.</p>	Copy exposure indicator	Description	Setting range	Initial setting	Exp. 1	First 2 digits	00 to 59 (min)	00	Exp. 3	Last 3 digits	000 to 999 (min)	000	Exp. 5	Clearing the drive time	_____	_____
Copy exposure indicator	Description	Setting range	Initial setting														
Exp. 1	First 2 digits	00 to 59 (min)	00														
Exp. 3	Last 3 digits	000 to 999 (min)	000														
Exp. 5	Clearing the drive time	_____	_____														
U158	<p>Checking/clearing the developing count</p> <p>Description Displays the developing count for checking, clearing or changing a figure, which is used as a reference when correcting the toner control. It is automatically cleared when U130 is executed.</p> <p>Purpose To check the developing count after replacing the developer.</p> <p>Method</p> <ol style="list-style-type: none"> 1. Press the start key. 2. Select the item by lighting a copy exposure indicator using the copy exposure adjustment keys. <table border="1" data-bbox="320 1272 1382 1413"> <thead> <tr> <th>Copy exposure indicator</th> <th>Description</th> <th>Setting range</th> <th>Initial setting</th> </tr> </thead> <tbody> <tr> <td>Exp. 1</td> <td>First 3 digits</td> <td>000 to 999</td> <td>000</td> </tr> <tr> <td>Exp. 3</td> <td>Last 3 digits</td> <td>000 to 999</td> <td>000</td> </tr> <tr> <td>Exp. 5</td> <td>Clearing the count</td> <td>_____</td> <td>_____</td> </tr> </tbody> </table> <p>Clearing</p> <ol style="list-style-type: none"> 1. Light exp. 5. 2. Press the start key. The count is cleared, and the indication for selecting a maintenance item No. appears. <p>Setting</p> <ol style="list-style-type: none"> 1. Change the count using the zoom +/- keys. 2. Press the start key. The count is cleared, and the indication for selecting a maintenance item No. appears. <p>Completion To exit this maintenance item without changing the count, press the stop/reset key. The indication for selecting a maintenance item No. appears.</p>	Copy exposure indicator	Description	Setting range	Initial setting	Exp. 1	First 3 digits	000 to 999	000	Exp. 3	Last 3 digits	000 to 999	000	Exp. 5	Clearing the count	_____	_____
Copy exposure indicator	Description	Setting range	Initial setting														
Exp. 1	First 3 digits	000 to 999	000														
Exp. 3	Last 3 digits	000 to 999	000														
Exp. 5	Clearing the count	_____	_____														

Maintenance item No.	Description												
<p>U161</p>	<p>Setting the fixing control temperature</p> <p>Description Changes the fixing control temperature.</p> <p>Purpose Normally no change is necessary. However, can be used to prevent curling or creasing of paper, or solve a fixing problem on thick paper.</p> <p>Method Press the start key. The screen for selecting an item is displayed.</p> <p>Setting</p> <ol style="list-style-type: none"> 1. Select the item to be set by lighting a copy exposure indicator using the copy exposure adjustment keys. 2. Change the setting using the zoom +/- keys. <table border="1" style="width: 100%; border-collapse: collapse;"> <thead> <tr> <th style="text-align: left;">Copy exposure indicator</th> <th style="text-align: left;">Description</th> <th style="text-align: left;">Setting range</th> <th style="text-align: left;">Initial setting</th> </tr> </thead> <tbody> <tr> <td>Exp. 1</td> <td>Primary stabilization fixing temperature</td> <td>100 to 165 (°C)</td> <td>125</td> </tr> <tr> <td>Exp. 3</td> <td>Secondary stabilization fixing temperature</td> <td>155 to 195 (°C)</td> <td>180</td> </tr> </tbody> </table> <p>The temperatures are to be set such that exp. 3 ≥ exp. 1.</p> <ol style="list-style-type: none"> 3. Press the start key. The value is set. <p>Completion To exit this maintenance item without changing the current setting, press the stop/reset key. The indication for selecting a maintenance item No. appears.</p>	Copy exposure indicator	Description	Setting range	Initial setting	Exp. 1	Primary stabilization fixing temperature	100 to 165 (°C)	125	Exp. 3	Secondary stabilization fixing temperature	155 to 195 (°C)	180
Copy exposure indicator	Description	Setting range	Initial setting										
Exp. 1	Primary stabilization fixing temperature	100 to 165 (°C)	125										
Exp. 3	Secondary stabilization fixing temperature	155 to 195 (°C)	180										
<p>U162</p>	<p>Stabilizing fixing forcibly</p> <p>Description Stops the stabilization fixing drive forcibly, regardless of fixing temperature.</p> <p>Purpose To forcibly stabilize the machine before the fixing section reaches stabilization temperature.</p> <p>Method</p> <ol style="list-style-type: none"> 1. Press the start key. "on" appears. 2. Press the start key. The forced stabilization mode is entered, and stabilization operation stops regardless of fixing temperature. The indication for selecting a maintenance item No. appears. To exit the forced stabilization mode, turn the power off and on. <p>Completion Press the stop/reset key. The indication for selecting a maintenance item No. appears.</p>												
<p>U163</p>	<p>Resetting the fixing problem data</p> <p>Description Resets the detection of a service call code indicating a problem in the fixing section.</p> <p>Purpose To prevent accidents due to an abnormally high fixing temperature.</p> <p>Method</p> <ol style="list-style-type: none"> 1. Press the start key. "CLE" appears. 2. Press the start key. The fixing problem data is initialized. <p>Completion Press the stop/reset key. The indication for selecting a maintenance item No. appears.</p>												

Maintenance item No.	Description						
U170	<p>Setting the drum cleaning mode</p> <p>Description Sets whether or not to apply toner to the drum and perform drum cleaning every paper interval.</p> <p>Purpose Set to “on” if an image problem occur such as black dots.</p> <p>Method Press the start key.</p> <p>Setting</p> <ol style="list-style-type: none"> 1. Select either “on” or “oFF” using the zoom +/- keys. <table border="1" data-bbox="320 551 1385 663"> <thead> <tr> <th data-bbox="320 551 699 591">Display</th> <th data-bbox="699 551 1385 591">Description</th> </tr> </thead> <tbody> <tr> <td data-bbox="320 591 699 631">on</td> <td data-bbox="699 591 1385 631">Drum cleaning mode on</td> </tr> <tr> <td data-bbox="320 631 699 663">oFF</td> <td data-bbox="699 631 1385 663">Drum cleaning mode off</td> </tr> </tbody> </table> <p>Initial setting: off</p> <ol style="list-style-type: none"> 2. Press the start key. The setting is set, and the indication for selecting a maintenance item No. appears. <p>Completion To exit this maintenance item without changing the current setting, press the stop/reset key. The indication for selecting a maintenance item No. appears.</p>	Display	Description	on	Drum cleaning mode on	oFF	Drum cleaning mode off
Display	Description						
on	Drum cleaning mode on						
oFF	Drum cleaning mode off						
U196	<p>Turning the fixing heater on</p> <p>Description Turns the fixing heater on.</p> <p>Purpose To check fixing heater.</p> <p>Method</p> <ol style="list-style-type: none"> 1. Press the start key. “on” appears. 2. Press the start key. The fixing heater turns on for 1 s and then turns off. <p>Completion Press the stop/reset key when fixing heater is off. The indication for selecting a maintenance item No. appears.</p>						
U199	<p>Checking the fixing temperature</p> <p>Description Displays the fixing temperature and the ambient temperature.</p> <p>Purpose To check the fixing temperature and the ambient temperature.</p> <p>Method</p> <ol style="list-style-type: none"> 1. Press the start key. 2. Display each temperature by lighting the respective copy exposure indicator using the copy exposure adjustment keys. <table border="1" data-bbox="320 1451 1385 1563"> <thead> <tr> <th data-bbox="320 1451 699 1491">Copy exposure indicator</th> <th data-bbox="699 1451 1385 1491">Description</th> </tr> </thead> <tbody> <tr> <td data-bbox="320 1491 699 1532">Exp. 1</td> <td data-bbox="699 1491 1385 1532">Fixing temperature (°C)</td> </tr> <tr> <td data-bbox="320 1532 699 1563">Exp. 3</td> <td data-bbox="699 1532 1385 1563">Ambient temperature (°C)</td> </tr> </tbody> </table> <p>Completion Press the stop/reset key. The indication for selecting a maintenance item No. appears.</p>	Copy exposure indicator	Description	Exp. 1	Fixing temperature (°C)	Exp. 3	Ambient temperature (°C)
Copy exposure indicator	Description						
Exp. 1	Fixing temperature (°C)						
Exp. 3	Ambient temperature (°C)						
U200	<p>Turning all LEDs on</p> <p>Description Turns all the LEDs on the operation panel on.</p> <p>Purpose To check if all the LEDs on the operation panel light.</p> <p>Method Press the start key. All the LEDs on the operation panel light. Press the stop/reset key or wait for 10 s. The LEDs turns off, and the indication for selecting a maintenance item No. appears.</p>						

Maintenance item No.	Description								
<p>U207</p>	<p>Checking the operation panel keys</p> <p>Description Checks operation of the operation panel keys.</p> <p>Purpose To check operation of all the keys and LEDs on the operation panel.</p> <p>Method</p> <ol style="list-style-type: none"> 1. Press the start key. 2. "1" appears on the copy quantity display and the leftmost LED on the operation panel lights. 3. As the keys on the operation panel are pressed in order from the left to right, the figure shown on the copy quantity display increases in increments of 1. If there is an LED corresponding to the key pressed, the LED will light. 4. When all the keys on the operation panel have been pressed, all the LEDs light for up to 10 seconds. 5. When the LEDs go off, press the start key. All the LEDs light for 10 seconds again. <p>Completion Press the stop/reset key. The indication for selecting a maintenance item No. appears.</p> <ul style="list-style-type: none"> • After this check starts, the operation cannot be canceled until all the keys are checked. 								
<p>U208</p>	<p>Setting the paper size</p> <p>Description Sets the size of paper loaded in the drawer.</p> <p>Purpose Used when changed the paper size in the drawer.</p> <p>Method</p> <ol style="list-style-type: none"> 1. Press the start key. 2. Select the paper size using the zoom +/- keys. <table border="1" data-bbox="300 1016 1362 1151"> <thead> <tr> <th data-bbox="300 1016 715 1061">Display</th> <th data-bbox="715 1016 1362 1061">Paper size</th> </tr> </thead> <tbody> <tr> <td data-bbox="300 1061 715 1095">A4r/814</td> <td data-bbox="715 1061 1362 1095">A4R/8¹/₂" × 14"</td> </tr> <tr> <td data-bbox="300 1095 715 1128">A5r/811</td> <td data-bbox="715 1095 1362 1128">A5R/8¹/₂" × 11"R</td> </tr> <tr> <td data-bbox="300 1128 715 1151">FOL/5H8</td> <td data-bbox="715 1128 1362 1151">Folio/5¹/₂" × 8¹/₂"R</td> </tr> </tbody> </table> <p>3. Press the start key. The setting is set.</p> <p>Completion To exit this maintenance mode without the current setting, press the stop/reset key while a selection item is displayed. The indication for selecting a maintenance item No. appears.</p>	Display	Paper size	A4r/814	A4R/8 ¹ / ₂ " × 14"	A5r/811	A5R/8 ¹ / ₂ " × 11"R	FOL/5H8	Folio/5 ¹ / ₂ " × 8 ¹ / ₂ "R
Display	Paper size								
A4r/814	A4R/8 ¹ / ₂ " × 14"								
A5r/811	A5R/8 ¹ / ₂ " × 11"R								
FOL/5H8	Folio/5 ¹ / ₂ " × 8 ¹ / ₂ "R								

Maintenance item No.	Description										
<p>U252</p>	<p>Setting the destination</p> <p>Description Switches the operations and screens of the machine according to the destination.</p> <p>Purpose To be executed after replacing the backup RAM on the main PCB or initializing the backup RAM by running maintenance item U020, in order to return the setting to the value before replacement or initialization.</p> <p>Method Press the start key.</p> <p>Setting</p> <ol style="list-style-type: none"> Select the destination using the zoom +/- keys. <table border="1" data-bbox="316 577 1378 748"> <thead> <tr> <th>Display</th> <th>Description</th> </tr> </thead> <tbody> <tr> <td>JPn</td> <td>Metric (Japan) specifications</td> </tr> <tr> <td>Inc</td> <td>Inch (North America) specifications</td> </tr> <tr> <td>EUP</td> <td>Metric (Europe) specifications</td> </tr> <tr> <td>ASA</td> <td>Metric (Asia Pacific) specifications</td> </tr> </tbody> </table> <ol style="list-style-type: none"> Press the start key. The setting is set, and the machine automatically returns to the same status as when the power is turned on. <p>Completion To exit this maintenance item without changing the current count, press the stop/reset key. The indication for selecting a maintenance item No. appears.</p>	Display	Description	JPn	Metric (Japan) specifications	Inc	Inch (North America) specifications	EUP	Metric (Europe) specifications	ASA	Metric (Asia Pacific) specifications
Display	Description										
JPn	Metric (Japan) specifications										
Inc	Inch (North America) specifications										
EUP	Metric (Europe) specifications										
ASA	Metric (Asia Pacific) specifications										

Maintenance item No.	Description						
<p>U254</p>	<p>Turning auto start function on/off</p> <p>Description Selects if the auto start function is turned on.</p> <p>Purpose Normally no change is necessary. If incorrect operation occurs, turn the function off: this may solve the problem.</p> <p>Method Press the start key.</p> <p>Setting</p> <p>1. Select either “on” or “oFF” using the zoom +/- keys.</p> <table border="1" data-bbox="304 577 1366 689"> <thead> <tr> <th data-bbox="304 577 683 622">Display</th> <th data-bbox="683 577 1366 622">Description</th> </tr> </thead> <tbody> <tr> <td data-bbox="304 622 683 656">on</td> <td data-bbox="683 622 1366 656">Auto start function on</td> </tr> <tr> <td data-bbox="304 656 683 689">oFF</td> <td data-bbox="683 656 1366 689">Auto start function off</td> </tr> </tbody> </table> <p>Initial setting: on</p> <p>2. Press the start key. The setting is set, and the indication for selecting a maintenance item No. appears.</p> <p>Completion To exit this maintenance item without changing the current setting, press the stop/reset key. The indication for selecting a maintenance item No. appears.</p>	Display	Description	on	Auto start function on	oFF	Auto start function off
Display	Description						
on	Auto start function on						
oFF	Auto start function off						

Maintenance item No.	Description						
U255	<p>Setting auto clear time</p> <p>Description Sets the time to return to initial settings after copying is complete.</p> <p>Purpose To be set according to frequency of use. Set to a comparatively long time for continuous copying at the same settings, and a comparatively short time for frequent copying at various settings.</p> <p>Method Press the start key. The current setting is displayed.</p> <p>Setting</p> <ol style="list-style-type: none"> 1. Change the setting using the zoom +/- keys. <table border="1" data-bbox="320 577 1382 660"> <thead> <tr> <th data-bbox="320 577 831 622">Description</th> <th data-bbox="831 577 1139 622">Setting range</th> <th data-bbox="1139 577 1382 622">Initial setting</th> </tr> </thead> <tbody> <tr> <td data-bbox="320 622 831 660">Auto clear time</td> <td data-bbox="831 622 1139 660">0 to 270</td> <td data-bbox="1139 622 1382 660">90</td> </tr> </tbody> </table> <p>The setting can be changed by 30 s per step. When set to 0, the auto clear function is cancelled.</p> <ol style="list-style-type: none"> 2. Press the start key. The value is set, and the indication for selecting a maintenance item No. appears. <p>Completion To exit this maintenance item without changing the current setting, press the stop/reset key. The indication for selecting a maintenance item No. appears.</p>	Description	Setting range	Initial setting	Auto clear time	0 to 270	90
Description	Setting range	Initial setting					
Auto clear time	0 to 270	90					
U256	<p>Turning auto preheat/energy saver function on/off</p> <p>Description Selects if the auto preheat/energy saver function is turned on. When set to ON, the time to enter preheat/energy saver mode can be changed in copy management mode.</p> <p>Purpose According to user request, to set the preheat time to save energy, or enable copying promptly without the recovery time from preheat mode.</p> <p>Method Press the start key.</p> <p>Setting</p> <ol style="list-style-type: none"> 1. Select "on" or "oFF" using the zoom +/- keys. <table border="1" data-bbox="320 1216 1382 1328"> <thead> <tr> <th data-bbox="320 1216 699 1261">Display</th> <th data-bbox="699 1216 1382 1261">Description</th> </tr> </thead> <tbody> <tr> <td data-bbox="320 1261 699 1294">on</td> <td data-bbox="699 1261 1382 1294">Auto preheat/energy saver function on</td> </tr> <tr> <td data-bbox="320 1294 699 1328">oFF</td> <td data-bbox="699 1294 1382 1328">Auto preheat/energy saver function off</td> </tr> </tbody> </table> <p>Initial setting: on</p> <ol style="list-style-type: none"> 2. Press the start key. The setting is set, and the indication for selecting a maintenance item No. appears. When the setting is changed from "oFF" to "on", the auto preheat time is set to the initial setting of 15 minutes. <p>Completion To exit this maintenance item without changing the current setting, press the stop/reset key. The indication for selecting a maintenance item No. appears.</p>	Display	Description	on	Auto preheat/energy saver function on	oFF	Auto preheat/energy saver function off
Display	Description						
on	Auto preheat/energy saver function on						
oFF	Auto preheat/energy saver function off						

Maintenance item No.	Description																					
<p>U258</p>	<p>Switching copy operation at toner empty detection</p> <p>Description Selects if continuous copying is enabled after toner empty is detected, and sets the number of copies that can be made after the detection.</p> <p>Method Press the start key. The current setting is displayed.</p> <p>Start</p> <ol style="list-style-type: none"> 1. Press the start key. A selection item appears. 2. Select the item by lighting image mode LEDs using the image mode selection key. <table border="1" style="width: 100%; border-collapse: collapse;"> <thead> <tr> <th style="width: 30%;">Image mode LEDs</th> <th style="width: 30%;">Description</th> <th style="width: 40%;"></th> </tr> </thead> <tbody> <tr> <td> <input type="radio"/> <input type="radio"/> <input type="radio"/> <input checked="" type="radio"/> </td> <td> <input type="radio"/> AutoExp. <input type="radio"/> Text & Photo <input type="radio"/> Photo <input checked="" type="radio"/> Text </td> <td>Switching copy operation at toner empty detection between single or continuous copying</td> </tr> <tr> <td> <input type="radio"/> <input type="radio"/> <input checked="" type="radio"/> <input checked="" type="radio"/> </td> <td> <input type="radio"/> AutoExp. <input type="radio"/> Text & Photo <input checked="" type="radio"/> Photo <input checked="" type="radio"/> Text </td> <td>Setting the number of copies after toner empty detection</td> </tr> </tbody> </table> <p>○ : Off, ● : On</p> <p>Setting copy operation at toner empty detection between single and continuous copying</p> <ol style="list-style-type: none"> 1. Select single or continuous copying using the zoom +/- keys. <table border="1" style="width: 100%; border-collapse: collapse;"> <thead> <tr> <th style="width: 40%;">Display</th> <th style="width: 60%;">Description</th> </tr> </thead> <tbody> <tr> <td>Sin</td> <td>Enables only single copying.</td> </tr> <tr> <td>Con</td> <td>Enables single and continuous copying.</td> </tr> </tbody> </table> <p>Initial setting: Sin</p> <ol style="list-style-type: none"> 2. Press the start key. The setting is set. <p>Setting the number of copies after toner empty detection</p> <ol style="list-style-type: none"> 1. Set the number of copies that can be made using the zoom +/- keys. <table border="1" style="width: 100%; border-collapse: collapse;"> <thead> <tr> <th style="width: 50%;">Description</th> <th style="width: 20%;">Setting range</th> <th style="width: 30%;">Initial setting</th> </tr> </thead> <tbody> <tr> <td>Number of copies after toner empty detection</td> <td>0 to 200 (copies)</td> <td>70</td> </tr> </tbody> </table> <p>The setting can be changed by 5 copies per step. When set to 0, the number of copies is not limited regardless of the setting for single or continuous copying.</p> <ol style="list-style-type: none"> 2. Press the start key. <p>Completion Press the stop/reset key while a selection item is displayed. The indication for selecting a maintenance item No. appears.</p>	Image mode LEDs	Description		<input type="radio"/> <input type="radio"/> <input type="radio"/> <input checked="" type="radio"/>	<input type="radio"/> AutoExp. <input type="radio"/> Text & Photo <input type="radio"/> Photo <input checked="" type="radio"/> Text	Switching copy operation at toner empty detection between single or continuous copying	<input type="radio"/> <input type="radio"/> <input checked="" type="radio"/> <input checked="" type="radio"/>	<input type="radio"/> AutoExp. <input type="radio"/> Text & Photo <input checked="" type="radio"/> Photo <input checked="" type="radio"/> Text	Setting the number of copies after toner empty detection	Display	Description	Sin	Enables only single copying.	Con	Enables single and continuous copying.	Description	Setting range	Initial setting	Number of copies after toner empty detection	0 to 200 (copies)	70
Image mode LEDs	Description																					
<input type="radio"/> <input type="radio"/> <input type="radio"/> <input checked="" type="radio"/>	<input type="radio"/> AutoExp. <input type="radio"/> Text & Photo <input type="radio"/> Photo <input checked="" type="radio"/> Text	Switching copy operation at toner empty detection between single or continuous copying																				
<input type="radio"/> <input type="radio"/> <input checked="" type="radio"/> <input checked="" type="radio"/>	<input type="radio"/> AutoExp. <input type="radio"/> Text & Photo <input checked="" type="radio"/> Photo <input checked="" type="radio"/> Text	Setting the number of copies after toner empty detection																				
Display	Description																					
Sin	Enables only single copying.																					
Con	Enables single and continuous copying.																					
Description	Setting range	Initial setting																				
Number of copies after toner empty detection	0 to 200 (copies)	70																				

Maintenance item No.	Description						
<p>U260</p>	<p>Changing the copy count timing</p> <p>Description Changes the copy count timing for the total counter and other counters.</p> <p>Purpose To be set according to user (copy service provider) request. If a paper jam occurs frequently in the eject section when the number of copies is counted at the time of paper ejection, copies are provided without copy counts. The copy service provider cannot charge for such copying. To prevent this, the copy timing should be made earlier. If a paper jam occurs frequently in the paper conveying or fixing sections when the number of copies is counted before the paper reaches those sections, copying is charged without a copy being made. To prevent this, the copy timing should be made later.</p> <p>Method Press the start key.</p> <p>Setting</p> <ol style="list-style-type: none"> Select the copy count timing using the zoom +/- keys. <table border="1" data-bbox="320 725 1382 837"> <thead> <tr> <th>Display</th> <th>Description</th> </tr> </thead> <tbody> <tr> <td>FEd</td> <td>When secondary paper feed starts</td> </tr> <tr> <td>EJE</td> <td>When the paper is ejected</td> </tr> </tbody> </table> <p>Initial setting: EJE</p> <ol style="list-style-type: none"> Press the start key. The setting is set, and the indication for selecting a maintenance item No. appears. <p>Completion To exit this maintenance item without changing the current setting, press the stop/reset key. The indication for selecting a maintenance item No. appears.</p>	Display	Description	FEd	When secondary paper feed starts	EJE	When the paper is ejected
Display	Description						
FEd	When secondary paper feed starts						
EJE	When the paper is ejected						

Maintenance item No.	Description																																																																						
<p>U332</p>	<p>Setting the size conversion factor</p> <p>Description Sets the factor for converting each paper size into A4/11" × 8¹/₂". The black ratio is converted for the A4/11" × 8¹/₂" size using the factor set in this maintenance item. Values set are displayed in the user simulation.</p> <p>Purpose To set the factor to convert the black ratio of each paper size for A4/11" × 8¹/₂" size.</p> <p>Method</p> <ol style="list-style-type: none"> 1. Press the start key. 2. Select the paper size to be set by lighting a copy exposure indicator or making one flash using the copy exposure adjustment keys. <p>Metric specifications</p> <table border="1" data-bbox="304 613 1398 922"> <thead> <tr> <th>Image mode LEDs</th> <th>Copy exposure indicator</th> <th>Paper size</th> <th>Setting range</th> <th>Initial setting</th> </tr> </thead> <tbody> <tr> <td><input type="radio"/> </td> <td>Exp. 1 (lit)</td> <td>A4R</td> <td>0.0 to 3.0</td> <td>1.0</td> </tr> <tr> <td><input type="radio"/> + </td> <td>Exp. 3 (lit)</td> <td>B5R</td> <td>0.0 to 3.0</td> <td>0.7</td> </tr> <tr> <td><input type="radio"/> </td> <td>Exp. 5 (lit)</td> <td>A5R</td> <td>0.0 to 3.0</td> <td>0.5</td> </tr> <tr> <td><input checked="" type="radio"/> </td> <td>Exp. 1 (flashing)</td> <td>B6R</td> <td>0.0 to 3.0</td> <td>0.4</td> </tr> <tr> <td></td> <td>Exp. 3 (flashing)</td> <td>A6R</td> <td>0.0 to 3.0</td> <td>0.3</td> </tr> <tr> <td></td> <td>Exp. 5 (flashing)</td> <td>Postcard</td> <td>0.0 to 3.0</td> <td>0.3</td> </tr> <tr> <td></td> <td>Exp. 1 (flashing)</td> <td>Folio</td> <td>0.0 to 3.0</td> <td>1.0</td> </tr> <tr> <td></td> <td>Exp. 3 (flashing)</td> <td>Non-standard</td> <td>0.0 to 3.0</td> <td>1.0</td> </tr> </tbody> </table> <p><input type="radio"/> : Off, <input checked="" type="radio"/> : On</p> <p>Inch specifications</p> <table border="1" data-bbox="304 1003 1398 1200"> <thead> <tr> <th>Image mode LEDs</th> <th>Copy exposure indicator</th> <th>Paper size</th> <th>Setting range</th> <th>Initial setting</th> </tr> </thead> <tbody> <tr> <td><input type="radio"/> AutoExp.</td> <td>Exp. 1 (lit)</td> <td>8¹/₂" × 14"</td> <td>0.0 to 3.0</td> <td>1.5</td> </tr> <tr> <td><input type="radio"/> Text & Photo</td> <td>Exp. 3 (lit)</td> <td>8¹/₂" × 11"R</td> <td>0.0 to 3.0</td> <td>1.0</td> </tr> <tr> <td><input type="radio"/> Photo</td> <td>Exp. 5 (lit)</td> <td>5¹/₂" × 8¹/₂"R</td> <td>0.0 to 3.0</td> <td>0.5</td> </tr> <tr> <td><input checked="" type="radio"/> Text</td> <td>Exp. 1 (flashing)</td> <td>Non-standard</td> <td>0.0 to 3.0</td> <td>1.0</td> </tr> </tbody> </table> <p><input type="radio"/> : Off, <input checked="" type="radio"/> : On</p> <ol style="list-style-type: none"> 3. Change the setting using the zoom +/- keys. 4. Press the start key. The value is set. <p>Completion To exit this maintenance item without changing the current setting, press the stop/reset key. The indication for selecting a maintenance item No. appears.</p>	Image mode LEDs	Copy exposure indicator	Paper size	Setting range	Initial setting	<input type="radio"/>	Exp. 1 (lit)	A4R	0.0 to 3.0	1.0	<input type="radio"/> +	Exp. 3 (lit)	B5R	0.0 to 3.0	0.7	<input type="radio"/>	Exp. 5 (lit)	A5R	0.0 to 3.0	0.5	<input checked="" type="radio"/>	Exp. 1 (flashing)	B6R	0.0 to 3.0	0.4		Exp. 3 (flashing)	A6R	0.0 to 3.0	0.3		Exp. 5 (flashing)	Postcard	0.0 to 3.0	0.3		Exp. 1 (flashing)	Folio	0.0 to 3.0	1.0		Exp. 3 (flashing)	Non-standard	0.0 to 3.0	1.0	Image mode LEDs	Copy exposure indicator	Paper size	Setting range	Initial setting	<input type="radio"/> AutoExp.	Exp. 1 (lit)	8 ¹ / ₂ " × 14"	0.0 to 3.0	1.5	<input type="radio"/> Text & Photo	Exp. 3 (lit)	8 ¹ / ₂ " × 11"R	0.0 to 3.0	1.0	<input type="radio"/> Photo	Exp. 5 (lit)	5 ¹ / ₂ " × 8 ¹ / ₂ "R	0.0 to 3.0	0.5	<input checked="" type="radio"/> Text	Exp. 1 (flashing)	Non-standard	0.0 to 3.0	1.0
Image mode LEDs	Copy exposure indicator	Paper size	Setting range	Initial setting																																																																			
<input type="radio"/>	Exp. 1 (lit)	A4R	0.0 to 3.0	1.0																																																																			
<input type="radio"/> +	Exp. 3 (lit)	B5R	0.0 to 3.0	0.7																																																																			
<input type="radio"/>	Exp. 5 (lit)	A5R	0.0 to 3.0	0.5																																																																			
<input checked="" type="radio"/>	Exp. 1 (flashing)	B6R	0.0 to 3.0	0.4																																																																			
	Exp. 3 (flashing)	A6R	0.0 to 3.0	0.3																																																																			
	Exp. 5 (flashing)	Postcard	0.0 to 3.0	0.3																																																																			
	Exp. 1 (flashing)	Folio	0.0 to 3.0	1.0																																																																			
	Exp. 3 (flashing)	Non-standard	0.0 to 3.0	1.0																																																																			
Image mode LEDs	Copy exposure indicator	Paper size	Setting range	Initial setting																																																																			
<input type="radio"/> AutoExp.	Exp. 1 (lit)	8 ¹ / ₂ " × 14"	0.0 to 3.0	1.5																																																																			
<input type="radio"/> Text & Photo	Exp. 3 (lit)	8 ¹ / ₂ " × 11"R	0.0 to 3.0	1.0																																																																			
<input type="radio"/> Photo	Exp. 5 (lit)	5 ¹ / ₂ " × 8 ¹ / ₂ "R	0.0 to 3.0	0.5																																																																			
<input checked="" type="radio"/> Text	Exp. 1 (flashing)	Non-standard	0.0 to 3.0	1.0																																																																			

Maintenance item No.	Description						
U348	<p>Setting the copy density adjustment range</p> <p>Description Selects the adjustment range for copy density from NORMAL and SPECIAL AREA (for wider range).</p> <p>Purpose To change the setting according to user request. When especially dark or light density is requested, set to SPECIAL AREA.</p> <p>Method Press the start key.</p> <p>Setting</p> <ol style="list-style-type: none"> Select the density range using the zoom +/- keys. <table border="1" data-bbox="320 577 1382 689"> <thead> <tr> <th data-bbox="320 577 699 622">Display</th> <th data-bbox="699 577 1382 622">Description</th> </tr> </thead> <tbody> <tr> <td data-bbox="320 622 699 656">SPC (special area)</td> <td data-bbox="699 622 1382 656">5 steps (enlargement mode)</td> </tr> <tr> <td data-bbox="320 656 699 689">nrL (normal)</td> <td data-bbox="699 656 1382 689">3 steps</td> </tr> </tbody> </table> <p>Initial setting: Normal</p> <ol style="list-style-type: none"> Press the start key. The setting is set, and the indication for selecting a maintenance item No. appears. <p>Completion To exit this maintenance item without changing the current setting, press the stop/reset key. The indication for selecting a maintenance item No. appears.</p>	Display	Description	SPC (special area)	5 steps (enlargement mode)	nrL (normal)	3 steps
Display	Description						
SPC (special area)	5 steps (enlargement mode)						
nrL (normal)	3 steps						
U402	<p>Adjusting margins of image printing</p> <p>Adjustment See page 1-6-10.</p>						
U403	<p>Adjusting margins for scanning an original on the contact glass</p> <p>Adjustment See page 1-6-26.</p>						

Maintenance item No.	Description																
U901	<p>Checking/clearing copy counts by paper feed locations</p> <p>Description Displays or clears copy counts by paper feed locations.</p> <p>Purpose To check the time to replace consumable parts. Also to clear the counts after replacing the consumable parts.</p> <p>Method</p> <ol style="list-style-type: none"> 1. Press the start key. 2. Select the paper feed location (group No.) for which the count is to be checked or cleared by lighting image mode LEDs using the image mode selection key. 3. Change the indication of the copy quantity display by lighting a copy exposure indicator using the copy exposure adjustment keys. <table border="1" style="width: 100%; border-collapse: collapse;"> <thead> <tr> <th style="width: 5%;">Image mode LED (group No.)</th> <th style="width: 25%;">Copy exposure indicator</th> <th style="width: 20%;">Copy exposure indicator</th> <th style="width: 50%;">Copy quantity display (count value)</th> </tr> </thead> <tbody> <tr> <td style="vertical-align: top;">1</td> <td style="vertical-align: top;"> <ul style="list-style-type: none"> <input type="radio"/> <input type="radio"/> <input type="radio"/> <input checked="" type="radio"/> </td> <td style="vertical-align: top;"> <ul style="list-style-type: none"> Exp. 1 Exp. 3 Exp. 5 </td> <td style="vertical-align: top;"> <ul style="list-style-type: none"> First 3 digits of bypass copy count Last 3 digits of bypass copy count Clearing the count (CLE) </td> </tr> <tr> <td style="vertical-align: top;">2</td> <td style="vertical-align: top;"> <ul style="list-style-type: none"> <input type="radio"/> <input type="radio"/> <input checked="" type="radio"/> <input checked="" type="radio"/> </td> <td style="vertical-align: top;"> <ul style="list-style-type: none"> Exp. 1 Exp. 3 Exp. 5 </td> <td style="vertical-align: top;"> <ul style="list-style-type: none"> First 3 digits of the drawer copy count Last 3 digits of the drawer copy count Clearing the count (CLE) </td> </tr> <tr> <td style="vertical-align: top;">3</td> <td style="vertical-align: top;"> <ul style="list-style-type: none"> <input checked="" type="radio"/> <input checked="" type="radio"/> <input checked="" type="radio"/> <input checked="" type="radio"/> </td> <td style="vertical-align: top;"> <ul style="list-style-type: none"> Exp. 1 </td> <td style="vertical-align: top;"> <ul style="list-style-type: none"> Clearing all counts (CLE) </td> </tr> </tbody> </table> <p>○ : Off, ● : On</p> <p>Clearing copy counts by paper feed locations</p> <ol style="list-style-type: none"> 1. Select the paper feed location to clear the count. 2. Light exp. 5 using the copy exposure adjustment key. 3. Press the start key. The count is cleared. <p>Clearing copy counts for all paper feed locations</p> <ol style="list-style-type: none"> 1. Select group 3. 2. Press the start key. The counts are cleared. <p>Completion Press the stop/reset key. The indication for selecting a maintenance item No. appears.</p>	Image mode LED (group No.)	Copy exposure indicator	Copy exposure indicator	Copy quantity display (count value)	1	<ul style="list-style-type: none"> <input type="radio"/> <input type="radio"/> <input type="radio"/> <input checked="" type="radio"/> 	<ul style="list-style-type: none"> Exp. 1 Exp. 3 Exp. 5 	<ul style="list-style-type: none"> First 3 digits of bypass copy count Last 3 digits of bypass copy count Clearing the count (CLE) 	2	<ul style="list-style-type: none"> <input type="radio"/> <input type="radio"/> <input checked="" type="radio"/> <input checked="" type="radio"/> 	<ul style="list-style-type: none"> Exp. 1 Exp. 3 Exp. 5 	<ul style="list-style-type: none"> First 3 digits of the drawer copy count Last 3 digits of the drawer copy count Clearing the count (CLE) 	3	<ul style="list-style-type: none"> <input checked="" type="radio"/> <input checked="" type="radio"/> <input checked="" type="radio"/> <input checked="" type="radio"/> 	<ul style="list-style-type: none"> Exp. 1 	<ul style="list-style-type: none"> Clearing all counts (CLE)
Image mode LED (group No.)	Copy exposure indicator	Copy exposure indicator	Copy quantity display (count value)														
1	<ul style="list-style-type: none"> <input type="radio"/> <input type="radio"/> <input type="radio"/> <input checked="" type="radio"/> 	<ul style="list-style-type: none"> Exp. 1 Exp. 3 Exp. 5 	<ul style="list-style-type: none"> First 3 digits of bypass copy count Last 3 digits of bypass copy count Clearing the count (CLE) 														
2	<ul style="list-style-type: none"> <input type="radio"/> <input type="radio"/> <input checked="" type="radio"/> <input checked="" type="radio"/> 	<ul style="list-style-type: none"> Exp. 1 Exp. 3 Exp. 5 	<ul style="list-style-type: none"> First 3 digits of the drawer copy count Last 3 digits of the drawer copy count Clearing the count (CLE) 														
3	<ul style="list-style-type: none"> <input checked="" type="radio"/> <input checked="" type="radio"/> <input checked="" type="radio"/> <input checked="" type="radio"/> 	<ul style="list-style-type: none"> Exp. 1 	<ul style="list-style-type: none"> Clearing all counts (CLE) 														

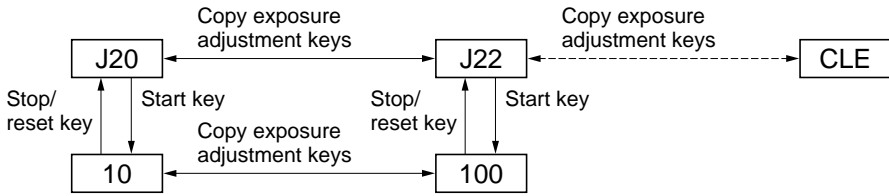
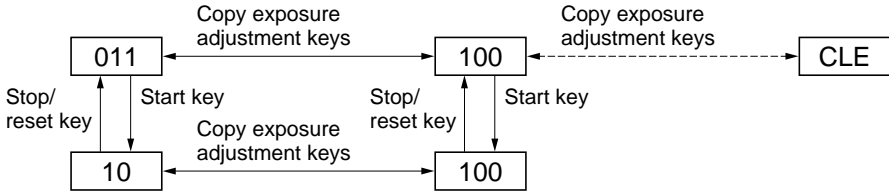
Maintenance item No.	Description
<p>U903</p>	<p>Checking/clearing the paper jam counts</p> <p>Description Displays or clears the jam counts by jam locations.</p> <p>Purpose To check the paper jam status. Also to clear the jam counts after replacing consumable parts.</p> <p>Method</p> <ol style="list-style-type: none"> 1. Press the start key. 2. Display the jam code to check the count using the copy exposure adjustment keys. 3. Press the start key. The jam count appears. If the jam count is a 4-digit value, the first digit and the last 3 digits are displayed alternately. 4. Press the stop/reset key. The jam code appears again.  <p style="text-align: center;">Figure 1-4-4</p> <p>Clearing all jam counts</p> <ol style="list-style-type: none"> 1. Display “CLE” using the copy exposure adjustment keys. Jam counts cannot be cleared individually. 2. Press the start key. The counts are cleared. <p>Completion Press the stop/reset key. The indication for selecting a maintenance item No. appears.</p>
<p>U904</p>	<p>Checking/clearing the service call counts</p> <p>Description Displays or clears the service call code counts by types.</p> <p>Purpose To check the service call code status by types. Also to clear the service call code counts after replacing consumable parts.</p> <p>Method</p> <ol style="list-style-type: none"> 1. Press the start key. 2. Display the service call code to check the count using the copy exposure adjustment keys. 3. Press the start key. The service call count appears. If the service call count is a 4-digit value, the first digit and the last 3 digits are displayed alternately. 4. Press the stop/reset key. The service call code appears again.  <p style="text-align: center;">Figure 1-4-5</p> <p>Clearing all service call counts</p> <ol style="list-style-type: none"> 1. Display “CLE” using the copy exposure adjustment keys. 2. Press the start key. The counts are cleared. <p>Completion Press the stop/reset key. The indication for selecting a maintenance item No. appears.</p>

Maintenance item No.	Description						
<p>U910</p>	<p>Clearing the black ratio data</p> <p>Description Clears the accumulated black ratio data for A4/11" × 8¹/₂" sheets.</p> <p>Purpose To clear data as required at times such as during maintenance service.</p> <p>Method</p> <ol style="list-style-type: none"> 1. Press the start key. 2. Select "on" using the zoom +/- keys. <table border="1" style="width: 100%; border-collapse: collapse;"> <thead> <tr> <th style="text-align: left;">Display</th> <th style="text-align: left;">Operation</th> </tr> </thead> <tbody> <tr> <td style="text-align: center;">---</td> <td>Canceling the clearing</td> </tr> <tr> <td style="text-align: center;">on</td> <td>Executing the clearing</td> </tr> </tbody> </table> <ol style="list-style-type: none"> 3. Press the start key. The accumulated black ratio data is cleared. <p>Completion To exit this maintenance item without clearing the data, press the stop/reset key. The indication for selecting a maintenance item No. appears.</p>	Display	Operation	---	Canceling the clearing	on	Executing the clearing
Display	Operation						
---	Canceling the clearing						
on	Executing the clearing						
<p>U917</p>	<p>Setting the reading/writing of backup data</p> <p>Description Selects whether to read out the backup data on the main PCB to the NVRAM on the memory tool PCB or to write backup data on the NVRAM on the memory tool PCB to the main PCB. When the memory is initialized (maintenance items U020, U021, U022 and U252), this is set to read out the backup data from the main PCB to the NVRAM on the memory tool PCB. To write the backup data to the main PCB from the NVRAM on the memory tool PCB, change the setting before starting writing.</p> <p>Purpose Used when replacing the main PCB.</p> <p>Method</p> <ol style="list-style-type: none"> 1. Press the start key. 2. Select "rd" or "rE" using the zoom +/- keys. <table border="1" style="width: 100%; border-collapse: collapse;"> <thead> <tr> <th style="text-align: left;">Display</th> <th style="text-align: left;">Description</th> </tr> </thead> <tbody> <tr> <td style="text-align: center;">rd</td> <td>Reading out the backup data</td> </tr> <tr> <td style="text-align: center;">rE</td> <td>Writing the backup data</td> </tr> </tbody> </table> <ol style="list-style-type: none"> 3. Press the start key. <p>Completion To exit this maintenance item without changing the current setting, press the stop/reset key. The indication for selecting a maintenance item No. appears.</p>	Display	Description	rd	Reading out the backup data	rE	Writing the backup data
Display	Description						
rd	Reading out the backup data						
rE	Writing the backup data						

Maintenance item No.	Description								
<p>U990</p>	<p>Checking/clearing the time for the exposure lamp to light</p> <p>Description Displays or clears the accumulated time for the exposure lamp to light.</p> <p>Purpose To check duration of use of the exposure lamp. Also to clear the accumulated time for the lamp after replacement.</p> <p>Method</p> <ol style="list-style-type: none"> 1. Press the start key. 2. Change the indication of the copy quantity display by lighting a copy exposure indicator using the copy exposure adjustment keys. <table border="1" data-bbox="320 573 1382 714"> <thead> <tr> <th data-bbox="320 573 699 613">Copy exposure indicator</th> <th data-bbox="699 573 1382 613">Copy quantity display</th> </tr> </thead> <tbody> <tr> <td data-bbox="320 613 699 649">Exp. 1</td> <td data-bbox="699 613 1382 649">First 3 digits of the lamp-on time (minutes)</td> </tr> <tr> <td data-bbox="320 649 699 683">Exp. 3</td> <td data-bbox="699 649 1382 683">Last 3 digits of the lamp-on time (minutes)</td> </tr> <tr> <td data-bbox="320 683 699 714">Exp. 5</td> <td data-bbox="699 683 1382 714">Clearing the lamp-on time (CLE)</td> </tr> </tbody> </table> <p>Clearing</p> <ol style="list-style-type: none"> 1. Light exp. 5. 2. Press the start key. The accumulated time is cleared, and the indication for selecting a maintenance item No. appears. <p>Completion To exit this maintenance item without changing the accumulated time, press the stop/reset key. The indication for selecting a maintenance item No. appears.</p>	Copy exposure indicator	Copy quantity display	Exp. 1	First 3 digits of the lamp-on time (minutes)	Exp. 3	Last 3 digits of the lamp-on time (minutes)	Exp. 5	Clearing the lamp-on time (CLE)
Copy exposure indicator	Copy quantity display								
Exp. 1	First 3 digits of the lamp-on time (minutes)								
Exp. 3	Last 3 digits of the lamp-on time (minutes)								
Exp. 5	Clearing the lamp-on time (CLE)								

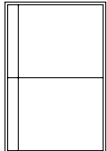
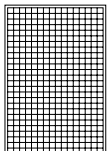
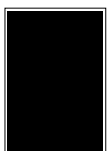
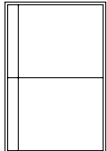
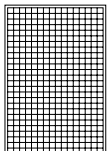
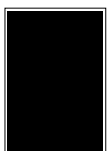
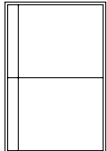
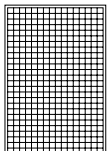
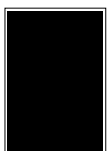
Maintenance item No.	Description												
<p>U993</p>	<p>Outputting a VTC-PG pattern</p> <p>Description Selects and outputs a VTC-PG pattern created in the copier.</p> <p>Purpose When performing respective image printing adjustments, used to check the machine status apart from that of the scanner with a non-scanned output VTC-PG pattern.</p> <p>Method</p> <ol style="list-style-type: none"> 1. Press the start key. 2. Select the VTC-PG pattern to be output using the copy exposure adjustment keys. <table border="1" data-bbox="304 544 1369 1111"> <thead> <tr> <th data-bbox="304 544 424 584">Display</th> <th data-bbox="424 544 724 584">PG pattern to be output</th> <th data-bbox="724 544 1369 584">Purpose</th> </tr> </thead> <tbody> <tr> <td data-bbox="304 584 424 757">0</td> <td data-bbox="424 584 724 757">  </td> <td data-bbox="724 584 1369 757"> <ul style="list-style-type: none"> • Center line adjustment </td> </tr> <tr> <td data-bbox="304 757 424 929">1</td> <td data-bbox="424 757 724 929">  </td> <td data-bbox="724 757 1369 929"> <ul style="list-style-type: none"> • Lateral squareness adjustment • Magnification adjustment </td> </tr> <tr> <td data-bbox="304 929 424 1111">2</td> <td data-bbox="424 929 724 1111">  </td> <td data-bbox="724 929 1369 1111"> <ul style="list-style-type: none"> • Checking the fixing performance (fixing pressure) </td> </tr> </tbody> </table> <ol style="list-style-type: none"> 3. Press the size select key. The machine enters the PG pattern output mode. 4. Press the start key. A VTC-PG pattern is output. <p>Completion Press the stop/reset key. The indication for selecting a maintenance item No. appears.</p>	Display	PG pattern to be output	Purpose	0		<ul style="list-style-type: none"> • Center line adjustment 	1		<ul style="list-style-type: none"> • Lateral squareness adjustment • Magnification adjustment 	2		<ul style="list-style-type: none"> • Checking the fixing performance (fixing pressure)
Display	PG pattern to be output	Purpose											
0		<ul style="list-style-type: none"> • Center line adjustment 											
1		<ul style="list-style-type: none"> • Lateral squareness adjustment • Magnification adjustment 											
2		<ul style="list-style-type: none"> • Checking the fixing performance (fixing pressure) 											

Maintenance item No.	Description												
<p>U998</p>	<p>Outputting the memory list</p> <p>Description Outputs the list of memory.</p> <p>Purpose To output the list as required.</p> <p>Method Press the start key.</p> <p>Entering the address</p> <ol style="list-style-type: none"> 1. Select the item by lighting a copy exposure indicator using the copy exposure adjustment keys. <table border="1" data-bbox="320 551 1382 689"> <thead> <tr> <th>Copy exposure indicator</th> <th>Description</th> <th>Setting range</th> </tr> </thead> <tbody> <tr> <td>Exp. 1</td> <td>Bit 16 to bit 23 of the address</td> <td>00 to FF</td> </tr> <tr> <td>Exp. 3</td> <td>Bit 8 to bit 15 of the address</td> <td>00 to FF</td> </tr> <tr> <td>Exp. 5</td> <td>Bit 0 to bit 7 of the address</td> <td>00 to FF</td> </tr> </tbody> </table> <ol style="list-style-type: none"> 2. Enter the address in hexadecimal using the zoom +/- keys. 3. Press the start key. The address is set. <p>Printing the list</p> <ol style="list-style-type: none"> 1. Press the size select key. The machine enters the list output mode. 2. Press the start key. The list is printed. <p>Completion Press the stop/reset key. The indication for selecting a maintenance item No. appears.</p>	Copy exposure indicator	Description	Setting range	Exp. 1	Bit 16 to bit 23 of the address	00 to FF	Exp. 3	Bit 8 to bit 15 of the address	00 to FF	Exp. 5	Bit 0 to bit 7 of the address	00 to FF
Copy exposure indicator	Description	Setting range											
Exp. 1	Bit 16 to bit 23 of the address	00 to FF											
Exp. 3	Bit 8 to bit 15 of the address	00 to FF											
Exp. 5	Bit 0 to bit 7 of the address	00 to FF											

1-5-1 Paper misfeed detection

(1) Paper misfeed indication

When a paper misfeed occurs, the copier immediately stops copying and displays the jam location on the operation panel. Paper misfeed counts sorted by the detection condition can be checked in maintenance item U903.

To remove paper jammed in the copier, open the paper conveying cover or pull the drawer out.

Paper misfeed detection can be reset by opening and closing the respective covers to turn safety switch off and on.

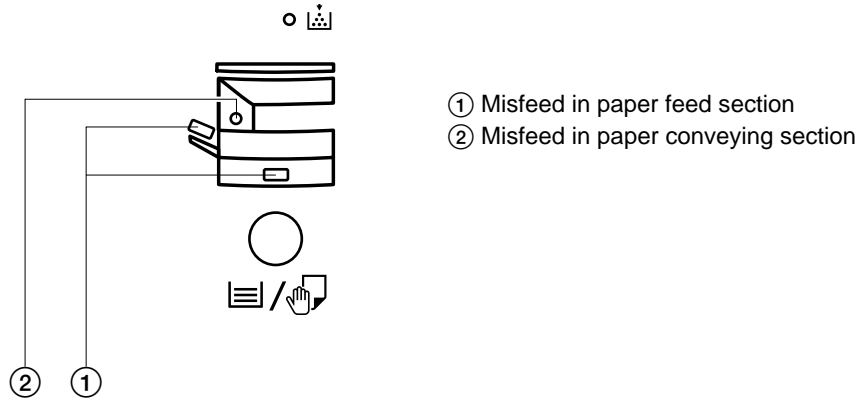

Figure 1-5-1

Jam code	Contents	See page
PF	No paper feed from drawer	P.1-5-3
PF	No paper feed from bypass	P.1-5-3
00	Jam at power-on	P.1-5-3
20	Multiple sheets in copier paper feed section	P.1-5-3
22	Multiple sheets in bypass tray	P.1-5-3
40	Misfeed in fixing section	P.1-5-4
50	Misfeed in eject section	P.1-5-4
95	Misfeed in registration section	P.1-5-4
96	Main charger problem	P.1-5-4
98	BD steady-state problem	P.1-5-4

Table 1-5-1

(2) Paper misfeed detection conditions

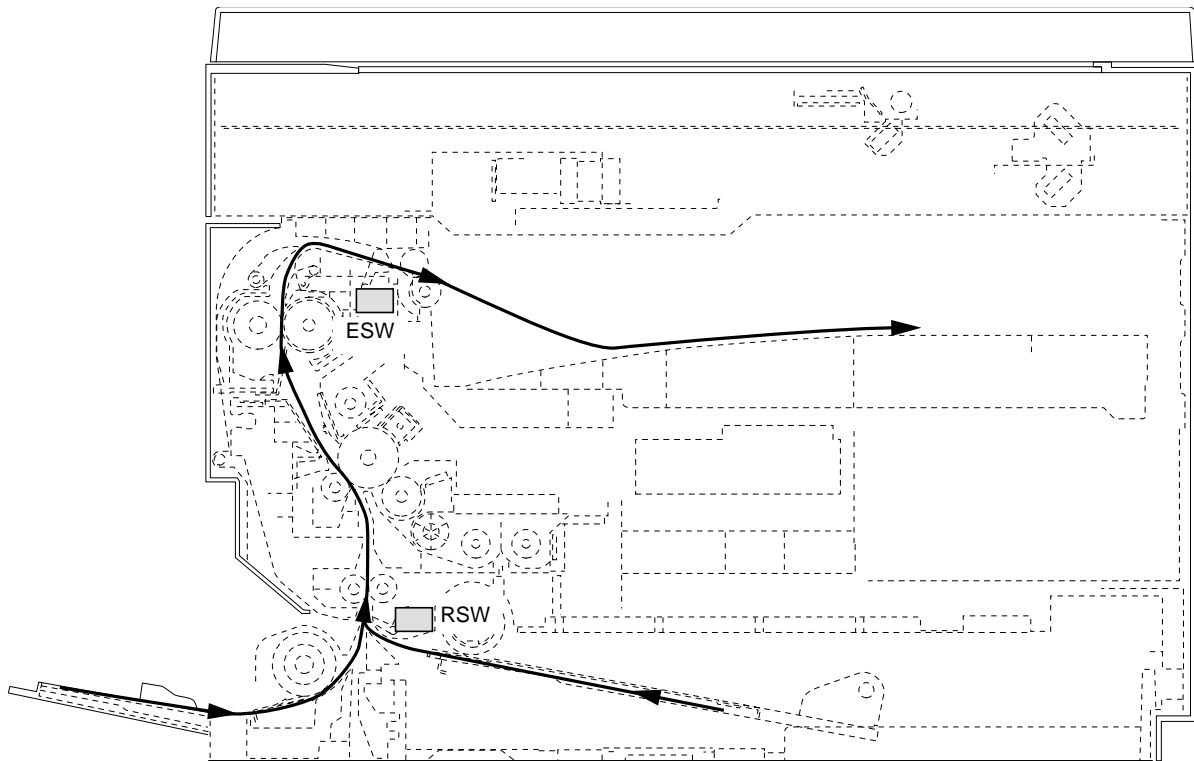

Figure 1-5-2

1. Jam at power-on

- One or more of the switches in the paper feed conveying system is on when the main switch is turned on (jam code 00).

2. Paper feed section

- No paper feed from drawer (“PF” appears on the copy quantity display.)

The registration switch (RSW) does not turn on within 1255 ms of the paper feed clutch (PFCL) turning on.

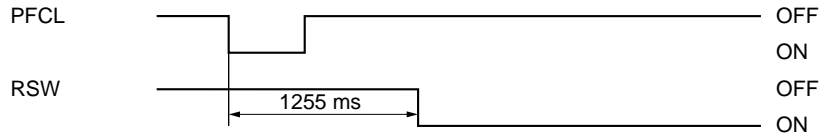

Timing chart 1-5-1

- No paper feed from bypass (“PF” appears on the copy quantity display.)

The registration switch (RSW) does not turn on within 1390 ms of the bypass paper feed clutch (BYPPFCL) turning on.

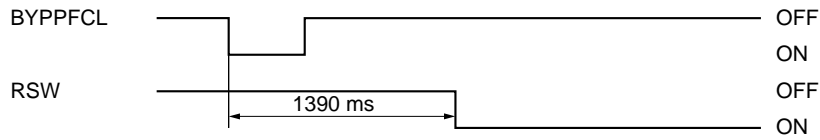

Timing chart 1-5-2

- Multiple sheets in copier paper feed section (jam code 20)

The registration switch (RSW) does not turn off within the time required to convey the length of the used paper size plus 2273 ms of turning on (when paper is fed from the drawer).

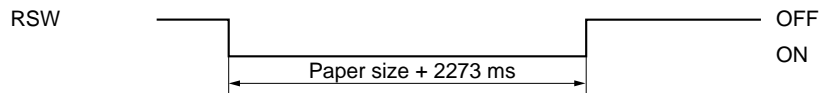

Timing chart 1-5-3

- Multiple sheets in bypass tray (jam code 22)

The registration switch (RSW) does not turn off within 5055 ms of turning on (when paper is fed from the bypass tray).

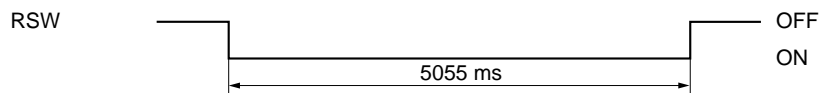

Timing chart 1-5-4

3. Fixing section

- Misfeed in fixing section (jam code 40)

The eject switch (ESW) does not turn on within 2809 ms of the registration clutch (RCL) turning on.

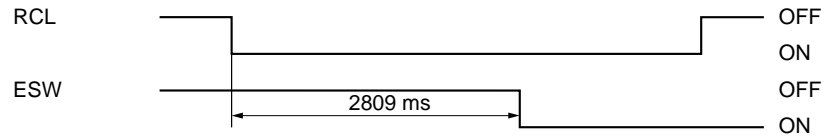

Timing chart 1-5-5

4. Eject section

- Misfeed in eject section (jam code 50)

The eject switch (ESW) does not turn off within 2809 ms of the registration switch (RSW) turning off.

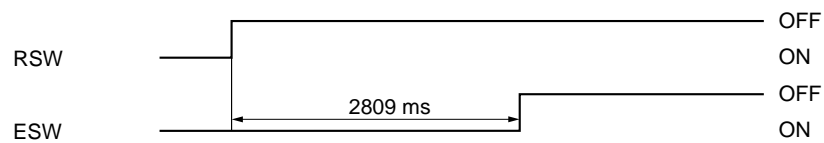

Timing chart 1-5-6

5. Misfeed in registration section

- Secondary paper feed does not start within 35 s of the end of primary paper feed. (jam code 95)

6. Main charger problem

- Leakage of the main charger is detected. (jam code 96)

7. BD steady-state problem

- BD steady-state problem is detected. (jam code 98)

(3) Paper misfeeds

Problem	Causes/check procedures	Corrective measures
(1) A paper jam in the paper feed, conveying, fixing or eject section is indicated as soon as the main switch is turned on.	A piece of paper torn from copy paper is caught around the registration switch or eject switch.	Check visually and remove any found.
	Defective registration switch.	With 5 V DC present at CN3-14 on the main PCB, check if CN3-13 on the main PCB remains low when the registration switch is turned on and off. If it does, replace the registration switch.
	Defective eject switch.	With 5 V DC present at CN11-6 on the main PCB, check if CN12-5 on the main PCB remains low when the eject switch is turned on and off. If it does, replace the eject switch.
(2) A paper jam in the paper feed section is indicated during copying (no paper feed from drawer). "PF" appears on the copy quantity display.	Paper in the drawer is extremely curled.	Change the paper.
	Check if the paper feed pulleys are deformed.	Check visually and replace the pulleys if deformed. (see page 1-6-3).
	Broken registration switch actuator.	Check visually and replace the registration switch if its actuator is broken.
	Defective registration switch.	With 5 V DC present at CN3-14 on the main PCB, check if CN3-13 on the main PCB remains low when the registration switch is turned on and off. If it does, replace the registration switch.
	Check if the paper feed clutch malfunctions.	Check and remedy if necessary.
	Electrical problem with the paper feed clutch.	Check (see page 1-5-20).
(3) A paper jam in the paper feed section is indicated during copying (no paper feed from bypass). "PF" appears on the copy quantity display.	Paper in the bypass tray is extremely curled.	Change the paper.
	Check if the bypass paper feed pulleys are deformed.	Check visually and replace the pulleys if deformed (see page 1-6-5).
	Broken registration switch actuator.	Check visually and replace the registration switch if its actuator is broken.
	Defective registration switch.	With 5 V DC present at CN3-14 on the main PCB, check if CN3-13 on the main PCB remains low when the registration switch is turned on and off. If not, replace the registration switch.
	Check if the bypass paper feed clutch malfunctions.	Check and remedy if necessary.
	Electrical problem with the bypass paper feed clutch.	Check (see page 1-5-20).
(4) A paper jam in the paper feed section is indicated during copying (multiple sheets in paper feed section). Jam code 20	Broken registration switch actuator.	Check visually and replace the registration switch if its actuator is broken.
	Defective registration switch.	With 5 V DC present at CN3-14 on the main PCB, check if CN3-13 on the main PCB remains low when the registration switch is turned on and off. If it does, replace the registration switch.
	Check if the right and left registration rollers contact each other.	Check visually and remedy if necessary.

Problem	Causes/check procedures	Corrective measures
(5) A paper jam in the paper feed section is indicated during copying (multiple sheets in bypass). Jam code 22	Broken registration switch actuator.	Check visually and replace the registration switch if its actuator is broken.
	Defective registration switch.	With 5 V DC present at CN3-14 on the main PCB, check if CN3-13 on the main PCB remains low when the registration switch is turned on and off. If it does, replace the registration switch.
	Check if the right and left registration rollers contact each other.	Check visually and remedy if necessary.
(6) A paper jam in the fixing section is indicated during copying (jam in fixing section). Jam code 40	Check if the registration clutch malfunctions.	Check and remedy if necessary.
	Electrical problem with the registration clutch.	Check (see page 1-5-19).
	Broken eject switch actuator.	Check visually and replace the eject switch if its actuator is broken.
	Defective eject switch.	With 5 V DC present at CN11-6 on the main PCB, check if CN11-5 on the main PCB remains low when the eject switch is turned on and off. If it does, replace the eject switch.
(7) A paper jam in the eject section is indicated during copying (jam in eject section). Jam code 50	Broken registration switch actuator.	Check visually and replace the registration switch if its actuator is broken.
	Defective registration switch.	With 5 V DC present at CN3-14 on the main PCB, check if CN3-13 on the main PCB remains low when the registration switch is turned on and off. If it does, replace the registration switch.
	Broken eject switch actuator.	Check visually and replace the eject switch if its actuator is broken.
	Defective eject switch.	With 5 V DC present at CN11-6 on the main PCB, check if CN11-5 on the main PCB remains low when the eject switch is turned on and off. If it does, replace the eject switch.

1-5-2 Self-diagnosis

(1) Self-diagnostic function

This unit is equipped with a self-diagnostic function. When a problem is detected, copying is disabled. "C" and a number between 011 and 731 alternates, indicating the nature of the problem.

After removing the problem, the self-diagnostic function can be reset by turning safety switch off and back on.

(2) Self diagnostic codes

Code	Contents	Remarks	
		Causes	Check procedures/corrective measures
A011 (C011)	Backup memory data problem <ul style="list-style-type: none"> Data in the specified area of the backup memory does not match the specified values. 	Problem with the backup memory data.	Turn safety switch off and back on and run maintenance item U020 to set the contents of the backup memory data again.
		Defective backup RAM.	If the C011 is displayed after re-setting the backup memory contents, replace the backup RAM.
A100 (C100)	Exposure lamp problem <ul style="list-style-type: none"> Check the CCD input value for the lighting status of the exposure lamp 100 ms after the exposure lamp is lit and the carriage is moved to the shading position. If the exposure lamp does not light, turn off the lamp. After 500 ms, light the lamp again and, a further 500 ms later, check the CCD input. The exposure lamp does not light after 5 retries. 	Poor contact of the connector terminals.	Check the connection of connector CN12 on the main PCB, and the continuity across the connector terminals. Repair or replace if necessary.
		Defective exposure lamp.	Replace the exposure lamp.
		Defective main PCB or inverter PCB.	Replace the main PCB or inverter PCB and check for correct operation.
		Incorrect shading position.	Adjust the position of the contact glass (shading plate). If the problem still occurs, replace the scanner home position switch.
		CCD PCB output problem.	Replace the ISU.
A104 (C104)	Optical system problem <ul style="list-style-type: none"> After AGC, correct input is not obtained at CCD. 	Poor contact of the connector terminals.	Check the connection of connector CN12 on the main PCB, and the continuity across the connector terminals. Repair or replace if necessary.
		Defective exposure lamp.	Replace the exposure lamp.
		Defective main PCB or inverter PCB.	Replace the main PCB or inverter PCB and check for correct operation.
		Incorrect shading position.	Adjust the position of the contact glass (shading plate). If the problem still occurs, replace the scanner home position switch.
		CCD PCB output problem.	Replace the ISU.

Code	Contents	Remarks	
		Causes	Check procedures/corrective measures
A310 (C310)	Scanner carriage problem • The home position is not correct when the power is turned on or at the start of copying using the contact glass.	Poor contact of the connector terminals.	Check the connection of connector CN15 on the main PCB and the continuity across the connector terminals. Remedy or replace if necessary.
		Defective scanner home position switch.	Replace the scanner home position switch.
		Defective main PCB.	Replace the main PCB and check for correct operation.
		Defective scanner motor.	Replace the scanner motor.
A400 (C400)	Polygon motor synchronization problem • The polygon motor does not reach a stable speed within 19 s of the polygon motor remote signal turning on.	Poor contact of the connector terminals.	Check the connection of connector CN3 on the main PCB and the continuity across the connector terminals. Remedy or replace if necessary.
		Defective polygon motor.	Replace the LSU.
		Defective power source PCB.	Check if 24 V DC is present at CN1-2 on the power source PCB. If not, replace the power source PCB.
A401 (C401)	Polygon motor steady-state problem • The polygon motor rotation is not stable for 400 ms after the polygon motor rotation has been stabilized.	Poor contact of the connector terminals.	Check the connection of connector CN3 on the main PCB and the continuity across the connector terminals. Remedy or replace if necessary.
		Defective polygon motor.	Replace the LSU.
		Defective power source PCB.	Check if 24 V DC is present at CN1-2 on the power source PCB. If not, replace the power source PCB.
A420 (C420)	BD steady-state problem • The VTC detects a BD error for 800 ms after the polygon motor rotation has been stabilized.	Poor contact of the connector terminals.	Check the connection of connector CN18 on the main PCB and the continuity across the connector terminals. Remedy or replace if necessary.
		Defective LSU.	Replace the LSU.
		Defective main PCB.	Replace the main PCB and check for correct operation.
A510 (C510)	Main charger problem • MC ALM signal is detected continuously for 800 ms when MC REM signal is turned on.	Poor contact of the high-voltage transformer PCB connector terminals.	Reinsert the connector. Also check for continuity within the connector cable. If none, repair or replace the cable.
		Defective high-voltage transformer PCB.	Replace the high-voltage transformer PCB.
		Leakage during main charging.	Check and clean the main charger unit.

Code	Contents	Remarks	
		Causes	Check procedures/corrective measures
A510 (C510)	Main charger problem <ul style="list-style-type: none"> MC ALM signal is detected continuously for 800 ms when MC REM signal is turned on. 	Deformed high-voltage transformer PCB terminal spring.	Replace the spring.
C610	Broken fixing heater wire <ul style="list-style-type: none"> It takes 15 s or more for the fixing temperature to reach 50°C/122°F after the power is turned on or the safety switch is turned off and on. It takes 10 s or more for the fixing temperature to reach 100°C/212°F from 50°C/122°F. It takes 24 s or more for the fixing temperature to reach the secondary stabilization fixing temperature from the primary stabilization fixing temperature. 	Fixing heater installed incorrectly.	Check and reinstall if necessary.
		Broken fixing heater wire.	Check for continuity. If none, replace fixing heater.
		Poor contact in the fixing unit thermistor connector terminals.	Check the connection of connector CN11 on the main PCB and the continuity across the connector terminals. Remedy or replace if necessary.
		Broken fixing unit thermistor wire. Fixing unit thermistor installed incorrectly.	Measure the resistance. If it is $\infty \Omega$, replace the fixing unit thermistor. Check and reinstall if necessary.
		Fixing unit thermostat triggered.	Check for continuity. If none, replace the fixing unit thermostat.
C620	Abnormally low fixing unit thermistor temperature <ul style="list-style-type: none"> The fixing temperature remains below 90°C/194°F for 10 s during copying. 	Fixing heater installed incorrectly.	Check and reinstall if necessary.
		Broken fixing heater wire.	Check for continuity. If none, replace fixing heater.
		Poor contact in the fixing unit thermistor connector terminals.	Check the connection of connector CN11 on the main PCB and the continuity across the connector terminals. Remedy or replace if necessary.
		Broken fixing unit thermistor wire.	Measure the resistance. If it is $\infty \Omega$, replace the fixing unit thermistor.
		Fixing unit thermistor installed incorrectly.	Check and reinstall if necessary.
		Fixing unit thermostat triggered.	Check for continuity. If none, replace the fixing unit thermostat.
C630	Abnormally high fixing unit thermistor temperature <ul style="list-style-type: none"> The fixing temperature exceeds 230°C/446°F for 10 s. 	Shorted fixing unit thermistor.	Measure the resistance. If it is 0Ω , replace the fixing unit thermistor.
		Broken fixing heater control circuit on the power source PCB.	Replace the power source PCB.

Code	Contents	Remarks	
		Causes	Check procedures/corrective measures
C710	Toner sensor problem <ul style="list-style-type: none"> • The sensor output voltage is outside the range of 0.5 to 4.5 V during toner control. • The toner sensor control voltage cannot be set within the setting range when maintenance item U130 is run. 	Defective toner sensor.	Replace the toner sensor.
		Poor contact of the toner sensor connector terminals.	Reinsert the connector. Also check for continuity within the connector cable. If none, repair or replace the cable.
		Developer problem.	Replace the developer.
A730 (C730)	Broken external temperature thermistor wire <ul style="list-style-type: none"> • The input voltage is above 4.5 V. 	Poor contact of the humidity sensor PCB connector terminals.	Reinsert the connector. Also check for continuity within the connector cable. If none, repair or replace the cable.
		Defective external temperature thermistor.	Replace the humidity sensor PCB.
A731 (C731)	Short-circuited external temperature thermistor <ul style="list-style-type: none"> • The input voltage is below 0.5 V. 	Poor contact of the humidity sensor PCB connector terminals.	Reinsert the connector. Also check for continuity within the connector cable. If none, repair or replace the cable.
		Defective external temperature thermistor.	Replace the humidity sensor PCB.

1-5-3 Image formation problems

(1) No image appears (entirely white).



See page 1-5-12

(2) No image appears (entirely black).



See page 1-5-12

(3) Image is too light.

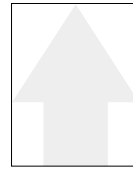

See page 1-5-13

(4) Background is visible.

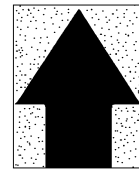

See page 1-5-13

(5) A white line appears longitudinally.

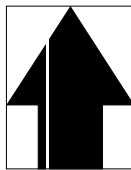

See page 1-5-13

(6) A black line appears longitudinally.

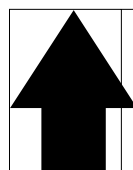

See page 1-5-14

(7) A black line appears laterally.

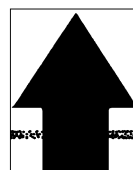

See page 1-5-14

(8) One side of the copy image is darker than the other.

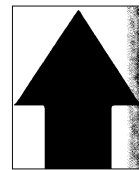

See page 1-5-14

(9) Black dots appear on the image.



See page 1-5-15

(10) Image is blurred.

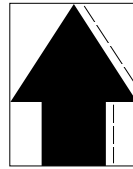

See page 1-5-15

(11) The leading edge of the image is consistently misaligned with the original.

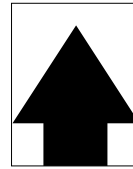

See page 1-5-15

(12) The leading edge of the image is sporadically misaligned with the original.

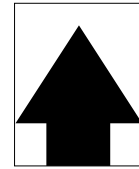

See page 1-5-16

(13) Paper creases.

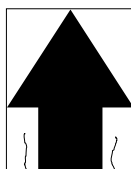

See page 1-5-16

(14) Offset occurs.

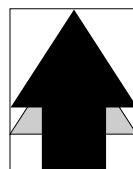

See page 1-5-16

(15) Image is partly missing.

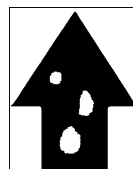

See page 1-5-17

(16) Fixing is poor.

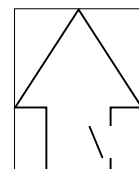

See page 1-5-17

(17) Image is out of focus.

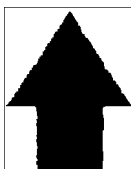

See page 1-5-17

(18) Image center does not align with the original center.

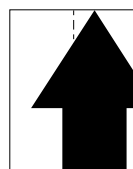

See page 1-5-18

(20) Image contrast is low (carrier scattering).

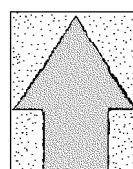

See page 1-5-18

2BT

(1) No image appears (entirely white).

Causes

1. No transfer charging.



Causes	Check procedures/corrective measures
1. No transfer charging.	
A. The connector terminals of the high-voltage transformer PCB make poor contact.	Reinsert the connector. Also check for continuity within the connector cable. If none, remedy or replace the cable.
B. Defective main PCB	Check if CN6-8 on the main PCB goes low when maintenance item U101 is run. If not, replace the main PCB.
C. Defective high-voltage transformer PCB.	Check if transfer charging takes place when CN1-8 on the high-voltage transformer PCB goes low while maintenance item U101 is run. If not, replace the high-voltage transformer PCB.

(2) No image appears (entirely black).

Causes

1. No main charging.
2. Exposure lamp fails to light.



Causes	Check procedures/corrective measures
1. No main charging.	
A. Broken main charger wire.	Replace the main charger unit.
B. Leaking main charger housing.	Clean the main charger wire, grid and shield.
C. The connector terminals of the high-voltage transformer PCB make poor contact.	Reinsert the connector. Also check for continuity within the connector cable. If none, remedy or replace the cable.
D. Defective main PCB.	Check if CN6-13 on the main PCB goes low when maintenance item U100 is run. If not, replace the main PCB.
E. Defective high-voltage transformer PCB.	Check if main charging takes place when CN1-3 on the high-voltage transformer PCB goes low while maintenance item U100 is run. If not, replace the high-voltage transformer PCB.
2. Exposure lamp fails to light.	
A. The connector terminals of the exposure lamp make poor contact.	Reinsert the connector. Also check for continuity within the connector cable. If none, remedy or replace the cable.
B. Defective inverter PCB.	Check if the exposure lamp lights when CN2-1 and 2-4 on the inverter PCB go low while maintenance item U061 is run. If not, replace the inverter PCB.
C. Defective main PCB.	Check if CN12-1 and 12-2 on the main PCB go low when maintenance item U061 is run. If not, replace the main PCB.

(3) Image is too light.



Causes

1. Insufficient toner.
2. Deteriorated developer.
3. Dirty or deteriorated drum.

Causes	Check procedures/corrective measures
1. Insufficient toner.	If the add toner indicator lights, replace the container.
2. Deteriorated developer.	Check the number of copies made with the current developer. If it has reached the specified limit, replace the developer.
3. Dirty or deteriorated drum.	Clean the drum or, if the maintenance level has been reached, replace the drum (see page 1-6-29).

(4) Background is visible.

Causes

1. Deteriorated developer.

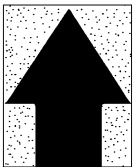

Causes	Check procedures/corrective measures
1. Deteriorated developer.	Check the number of copies made with the current developer. If it has reached the specified limit, replace the developer.

(5) A white line appears longitudinally.

Causes

1. Dirty or flawed main charger wire.
2. Foreign matter in the developing section.
3. Flawed drum.
4. Dirty shading plate.

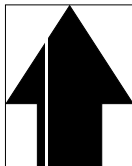

Causes	Check procedures/corrective measures
1. Dirty or flawed main charger wire.	Clean the main charger wire or, if it is flawed, replace the main charger unit.
2. Foreign matter in the developing section.	Check if the magnetic brush is formed uniformly. If not, replace the developer.
3. Flawed drum.	Replace the drum (see page 1-6-29).
4. Dirty shading plate.	Clean the shading plate.

2BT

(6) A black line appears longitudinally.

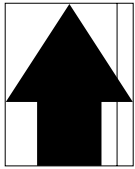

Causes

1. Dirty contact glass.
2. Dirty or flawed drum.
3. Deformed or worn cleaning blade.
4. Dirty scanner mirror.

Causes	Check procedures/corrective measures
1. Dirty contact glass.	Clean the contact glass.
2. Dirty or flawed drum.	Clean the drum or, if it is flawed, replace it (see page 1-6-29).
3. Deformed or worn cleaning blade.	Replace the cleaning blade (see page 1-6-31).
4. Dirty scanner mirror.	Clean the scanner mirror.

(7) A black line appears laterally.

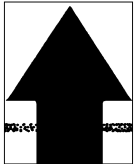

Causes

1. Flawed drum.
2. Dirty developing section.
3. Leaking main charger housing.

Causes	Check procedures/corrective measures
1. Flawed drum.	Replace the drum (see page 1-6-29).
2. Dirty developing section.	Clean any part contaminated with toner or carrier in the developing section.
3. Leaking main charger housing.	Clean the main charger wire, grid and shield.

(8) One side of the copy image is darker than the other.

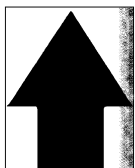

Causes

1. Dirty main charger wire.
2. Defective exposure lamp.

Causes	Check procedures/corrective measures
1. Dirty main charger wire.	Clean the wire or, if it is extremely dirty, replace the main charger unit.
2. Defective exposure lamp.	Check if the exposure lamp light is distributed evenly. If not, replace the exposure lamp (see page 1-6-12).

(9) Black dots appear on the image.

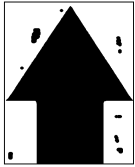

Causes

1. Dirty or flawed drum.
2. Dirty contact glass.
3. Deformed or worn cleaning blade.

Causes	Check procedures/corrective measures
1. Dirty or flawed drum.	Clean the drum or, if it is flawed, replace it (see page 1-6-29).
2. Dirty contact glass.	Clean the contact glass.
3. Deformed or worn cleaning blade.	Replace the cleaning blade (see page 1-6-31).

(10) Image is blurred.

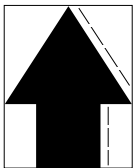

Causes

1. Scanner moves erratically.
2. Deformed press roller.
3. Paper conveying section drive problem.

Causes	Check procedures/corrective measures
1. Scanner moves erratically.	Check if there is any foreign matter on the front and rear scanner rails. If any, remove it.
2. Deformed press roller.	Replace the press roller (see page 1-6-38).
3. Paper conveying section drive problem.	Check the gears and belts and, if necessary, grease them.

(11) The leading edge of the image is consistently misaligned with the original.

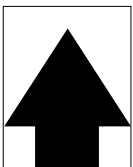

Causes

1. Misadjusted leading edge registration.
2. Misadjusted scanner leading edge registration.

Causes	Check procedures/corrective measures
1. Misadjusted leading edge registration.	Readjust the leading edge registration (see pages 1-6-8).
2. Misadjusted scanner leading edge registration.	Readjust the scanner leading edge registration (see page 1-6-24).

(12) The leading edge of the image is sporadically misaligned with the original.

Causes

1. Registration clutch, bypass paper feed clutch or paper feed clutch installed or operating incorrectly.

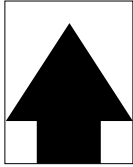

Causes	Check procedures/corrective measures
1. Registration clutch, bypass paper feed clutch or paper feed clutch installed or operating incorrectly.	Check the installation position and operation of the registration clutch, bypass paper feed clutch and paper feed clutches. If any of them operates incorrectly, replace it.

(13) Paper creases.

Causes

1. Paper curled.
2. Paper damp.
3. Defective pressure springs.

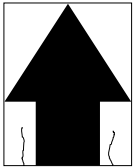

Causes	Check procedures/corrective measures
1. Paper curled.	Check the paper storage conditions.
2. Paper damp.	Check the paper storage conditions.
3. Defective pressure springs.	Replace the pressure springs.

(14) Offset occurs.

Causes

1. Defective cleaning blade.
2. Defective pressure springs.
3. Incorrect fixing temperature.

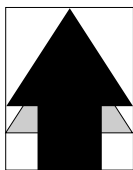

Causes	Check procedures/corrective measures
1. Defective cleaning blade.	Replace the cleaning blade (see page 1-6-31).
2. Defective pressure springs.	Replace the pressure springs.
3. Incorrect fixing temperature.	Run maintenance item U161 and check the fixing temperature.

(15) Image is partly missing.

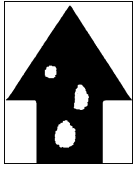

Causes

1. Paper damp.
2. Paper creased.
3. Drum condensation.
4. Flawed drum.

Causes	Check procedures/corrective measures
1. Paper damp.	Check the paper storage conditions.
2. Paper creased.	Replace the paper.
3. Drum condensation.	Clean the drum.
4. Flawed drum.	Replace the drum (see page 1-6-29).

(16) Fixing is poor.

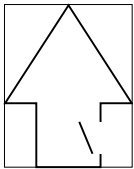

Causes

1. Wrong paper.
2. Defective pressure springs.
3. Flawed press roller.

Causes	Check procedures/corrective measures
1. Wrong paper.	Check if the paper meets specifications.
2. Defective pressure springs.	Replace the pressure springs.
3. Flawed press roller.	Replace the press roller (see page 1-6-38).

(17) Image is out of focus.

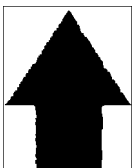

Causes

1. Defective image scanning unit.

Causes	Check procedures/corrective measures
1. Defective image scanning unit.	Replace the image scanning unit (see page 1-6-20).

(18) Image center does not align with the original center.

Causes

1. Misadjusted center line of image printing.
2. Misadjusted scanner center line.
3. Original placed incorrectly.

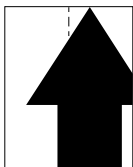

Causes	Check procedures/corrective measures
1. Misadjusted center line of image printing.	Readjust the center line of image printing (see pages 1-6-9).
2. Misadjusted scanner center line.	Readjust the scanner center line (see page 1-6-25).
3. Original placed incorrectly.	Place the original correctly.

(19) Image contrast is low (carrier scattering).

Causes

1. No developing bias output.

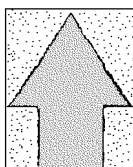

Causes	Check procedures/corrective measures
1. No developing bias output.	
A. Developing bias wire makes poor contact.	Check the developing bias wire. If there are any problems, replace it.
B. The connector terminals of the high-voltage transformer PCB make poor contact.	Reinsert the connector. Also check for continuity within the connector cable. If none, remedy or replace the cable.
C. Defective main PCB.	Check if CN6-10 on the main PCB goes low when maintenance item U030 is run. If not, replace the main PCB.
D. Defective high-voltage transformer PCB.	Check if developing bias is output when there is no problem with the main PCB while maintenance item U030 is run. If not, replace the high-voltage transformer PCB.

1-5-4 Electrical problems

Problem	Causes	Check procedures/corrective measures
(1) The machine does not operate when the main switch is turned on.	No electricity at the power outlet.	Measure the input voltage.
	The power cord is not plugged in properly.	Check the contact between the power plug and the outlet.
	The front cover and/or paper conveying cover are/is not closed completely.	Check the front cover and paper conveying cover.
	Broken power cord.	Check for continuity. If none, replace the cord.
	Defective main switch.	Check for continuity across the contacts. If none, replace the main switch.
	Blown fuse in the power source PCB.	Check for continuity. If none, remove the cause of blowing and replace the fuse.
	Defective safety switch.	Check for continuity across the contacts. If none, replace the safety switch.
(2) The drive motor does not operate .	Defective power source PCB.	With AC present, check for 5 V DC at CN1-7 on the power source PCB, 12 V DC at CN1-8 and 24 V DC at CN1-2. If none, replace the power source PCB.
	Poor contact in the drive motor connector terminals.	Reinsert the connector. Also check for continuity within the connector cable. If none, remedy or replace the cable.
	Broken drive motor gear.	Check visually and replace the drive motor if necessary.
(3) The scanner motor does not operate.	Defective drive motor.	Run maintenance item U030 and check if the drive motor operates when CN13-5 on the main PCB goes low. If not, replace the drive motor.
	Broken scanner motor coil.	Check for continuity across the coil. If none, replace the scanner motor.
(4) The toner feed motor does not operate.	Poor contact in the scanner motor connector terminals.	Reinsert the connector. Also check for continuity within the connector cable. If none, remedy or replace the cable.
	Broken toner feed motor coil.	Check for continuity across the coil. If none, replace the toner feed motor.
(5) Cooling fan motor does not operate.	Poor contact in the toner feed motor connector terminals.	Reinsert the connector. Also check for continuity within the connector cable. If none, repair or replace the cable.
	Broken cooling fan motor coil.	Check for continuity across the coil. If none, replace cooling fan motor.
(6) The registration clutch does not operate.	Poor contact in the cooling fan motor connector terminals.	Reinsert the connector. Also check for continuity within the connector cable. If none, repair or replace the cable.
	Broken registration clutch coil.	Check for continuity across the coil. If none, replace the registration clutch.
(6) The registration clutch does not operate.	Poor contact in the registration clutch connector terminals.	Reinsert the connector. Also check for continuity within the connector cable. If none, remedy or replace the cable.

Problem	Causes	Check procedures/corrective measures
(7) The paper feed clutch does not operate.	Broken paper feed clutch coil.	Check for continuity across the coil. If none, replace the paper feed clutch.
	Poor contact in the paper feed clutch connector terminals.	Reinsert the connector. Also check for continuity within the connector cable. If none, remedy or replace the cable.
(8) The bypass paper feed clutch does not operate.	Broken bypass paper feed clutch coil.	Check for continuity across the coil. If none, replace the bypass paper feed clutch.
	Poor contact in the bypass paper feed clutch connector terminals.	Reinsert the connector. Also check for continuity within the connector cable. If none, remedy or replace the cable.
(9) The cleaning lamp does not turn on.	Poor contact in the cleaning lamp connector terminals.	Reinsert the connector. Also check for continuity within the connector cable. If none, remedy or replace the cable.
	Defective cleaning lamp.	Check for continuity. If none, replace the cleaning lamp.
(10) The exposure lamp does not turn on.	Poor contact in the exposure lamp connector terminals.	Reinsert the connector. Also check for continuity within the connector cable. If none, remedy or replace the cable.
	Defective inverter PCB.	If the exposure lamp does not turn on when CN12-1 and CN12-2 on the main PCB are held low, replace the inverter PCB.
(11) The exposure lamp does not turn off.	Defective inverter PCB.	If the exposure lamp does not turn off when CN12-1 and CN12-2 on the main PCB are held high, replace the inverter PCB.
(12) The fixing heater does not turn on (C610).	Broken wire in fixing heater.	Check for continuity across the heater. If none, replace the heater.
	Fixing unit thermostat triggered.	Check for continuity across the thermostat. If none, remove the cause and replace the thermostat.
	Broken fixing unit thermistor wire.	Measure the resistance. If it is $\infty \Omega$, replace the fixing unit thermistor.
(13) The fixing heater does not turn off.	Dirty sensor part of the fixing unit thermistor.	Check visually and clean the thermistor sensor parts.
(14) Main charging is not performed (C510).	Broken main charger wire.	See page 1-5-12.
	Leaking main charger housing.	
	Poor contact in the high-voltage transformer PCB connector terminals.	
	Defective main PCB.	
	Defective high-voltage transformer PCB .	

Problem	Causes	Check procedures/corrective measures
(15) Transfer charging is not performed.	Poor contact in the high-voltage transformer PCB connector terminals.	See page 1-5-12.
	Defective main PCB.	
	Defective high-voltage transformer PCB .	
(16) No developing bias is output.	Poor contact in the developing bias wire.	See page 1-5-18.
	Poor contact in the high-voltage transformer PCB connector terminals.	
	Defective main PCB.	
	Defective high-voltage transformer PCB .	
(17) A paper jam in the paper feed, paper conveying or fixing section is indicated when the main switch is turned on.	A piece of paper torn from copy paper is caught around the registration switch or eject switch.	Check and remove if any.
	Defective registration switch.	With 5 V DC present at CN3-14 on the main PCB, check if CN3-3 on the main PCB remains low when the registration switch is turned on and off. If it does, replace the registration switch.
	Defective eject switch.	With 5 V DC present at CN11-6 on the main PCB, check if CN11-5 on the main PCB remains low when the eject switch is turned on and off. If it does, replace the eject switch.
(18) The message requesting covers to be closed is displayed when the front cover and paper conveying cover are closed.	Poor contact in the connector terminals of safety switch.	Reinsert the connector. Also check for continuity within the connector cable. If none, remedy or replace the cable.
	Defective safety switch.	Check for continuity across the contacts of the switch. If there is no continuity when the switch is on, replace it.
(19) Others.	Wiring is broken, shorted or makes poor contact.	Check for continuity. If none, repair.
	Noise.	Locate the source of noise and remove.

1-5-5 Mechanical problems

Problem	Causes/check procedures	Corrective measures
(1) No primary paper feed.	Check if the surfaces of the following pulleys are dirty with paper powder: paper feed pulleys and bypass paper feed pulleys.	Clean with isopropyl alcohol.
	Check if the paper feed pulleys are deformed.	Check visually and replace any deformed pulleys (see page 1-6-3).
	Electrical problem with the following electromagnetic clutches: paper feed clutch and bypass paper feed clutch.	See pages 1-5-20.
(2) No secondary paper feed.	Check if the surfaces of the left and right registration rollers are dirty with paper powder.	Clean with isopropyl alcohol.
	Electrical problem with the registration clutch.	See page 1-5-19.
(3) Skewed paper feed.	Deformed width guide in a drawer.	Repair or replace if necessary .
	Check if a pressure spring along the paper conveying path is deformed or out of place.	Repair or replace.
(4) The scanner does not travel.	Check if the scanner wire is loose.	Reinstall the scanner wire (see page 1-6-14).
	The scanner motor malfunctions.	See page 1-5-19.
(5) Multiple sheets of paper are fed at one time.	Deformed drawer claw.	Check the drawer claw visually and correct or replace if necessary.
	Check if the paper is curled.	Change the paper.
(6) Paper jams.	Check if the paper is excessively curled.	Change the paper.
	Deformed guides along the paper conveying path.	Check visually and replace any deformed guides.
	Check if the contact between the right and left registration rollers is correct.	Check visually and remedy if necessary. Replace the pressure spring if it is deformed.
	Check if the press roller is extremely dirty or deformed.	Clean or replace the press roller.
	Check if the contact between the heat roller and its separation claws is correct.	Repair if any springs are off the separation claws.
(7) Toner drops on the paper conveying path.	Check if the developing section of the image formation unit is extremely dirty.	Clean the developing section of the image formation unit.
(8) Abnormal noise is heard.	Check if the pulleys, rollers and gears operate smoothly.	Grease the bearings and gears.
	Check if the following electromagnetic clutches are installed correctly: paper feed clutch and bypass paper feed clutch.	Correct.

1-6-1 Precautions for assembly and disassembly

(1) Precautions

- Be sure to turn the main switch off and disconnect the power plug before starting disassembly.
- When handling PCBs, do not touch connectors with bare hands or damage the board.
- Do not touch any PCB containing ICs with bare hands or any object prone to static charge.
- Use only the specified parts to replace the fixing unit thermostat. Never substitute electric wires, as the copier may be seriously damaged.
- Do not perform aging without the waste toner tank installed during maintenance service.
- Use the following testers when measuring voltages:
 - Hioki 3200
 - Sanwa MD-180C
 - Sanwa YX-360TR
 - Beckman TECH300
 - Beckman DM45
 - Beckman 330*
 - Beckman 3030*
 - Beckman DM850*
 - Fluke 8060A*
 - Arlec DMM1050
 - Arlec YF1030C
- * Capable of measuring RMS values.
- Prepare the following as test originals:
 1. NTC (new test chart)
 2. NPTC (newspaper test chart)

(2) Running a maintenance item

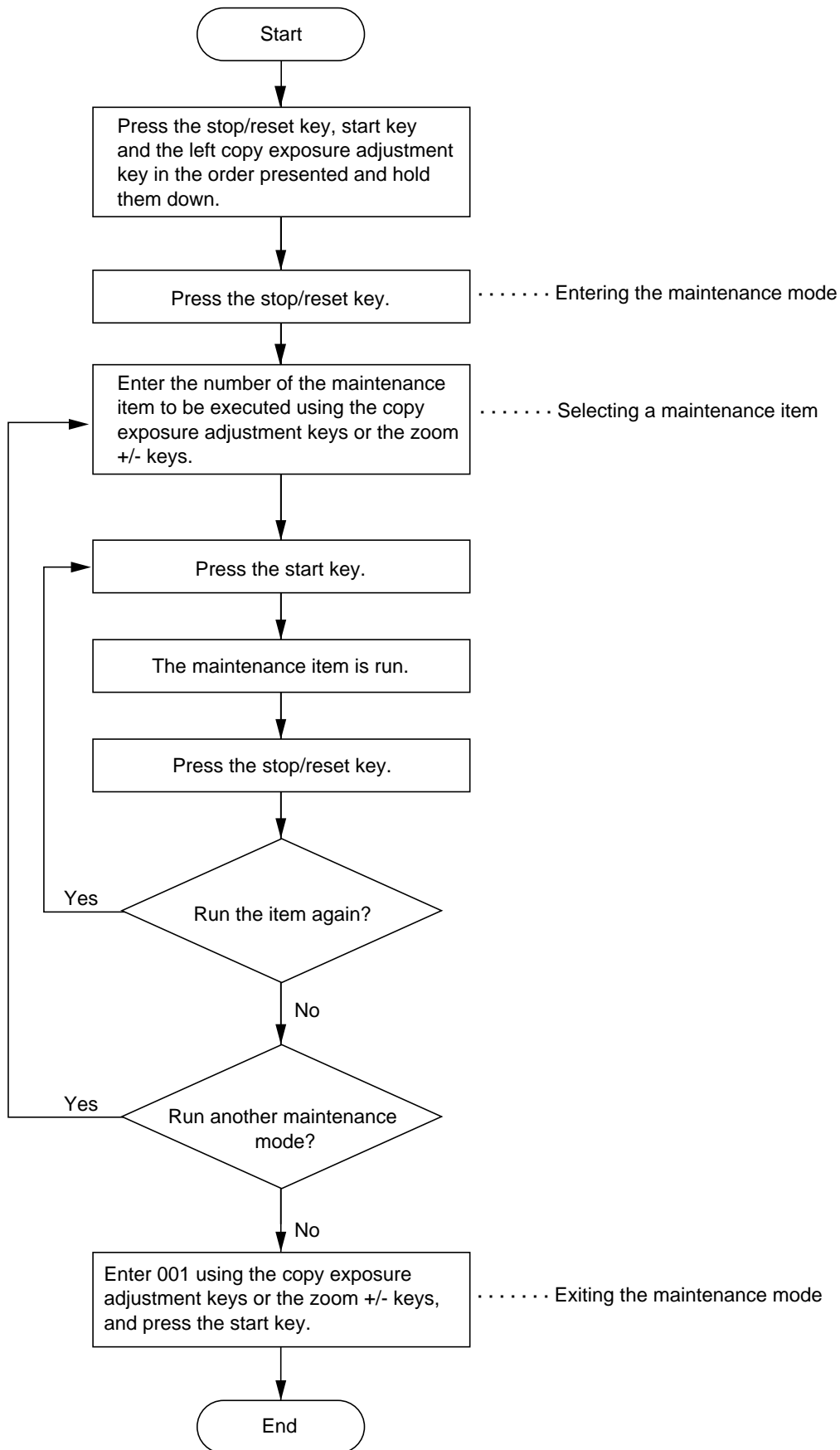

1-6-2 Paper feed section

(1) Detaching and refitting the paper feed pulleys

Follow the procedure below to replace the paper feed pulleys.

Procedure

1. Remove the printer cover and rear cover. Pull out the drawer.
2. Remove the four screws and then detach the high-voltage transfer PCB.

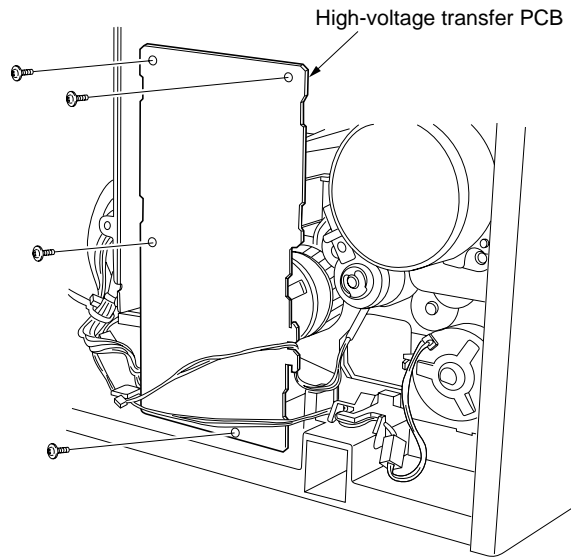

Figure 1-6-1

3. Remove the stop ring and then the paper feed clutch.

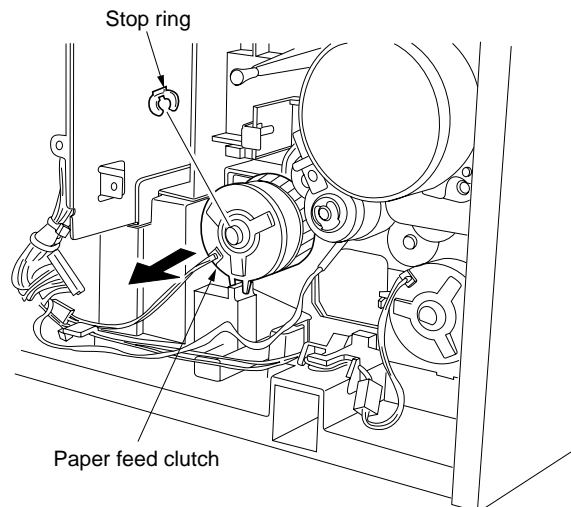

Figure 1-6-2

4. Remove the stop ring and bushing from the paper feed shaft unit.

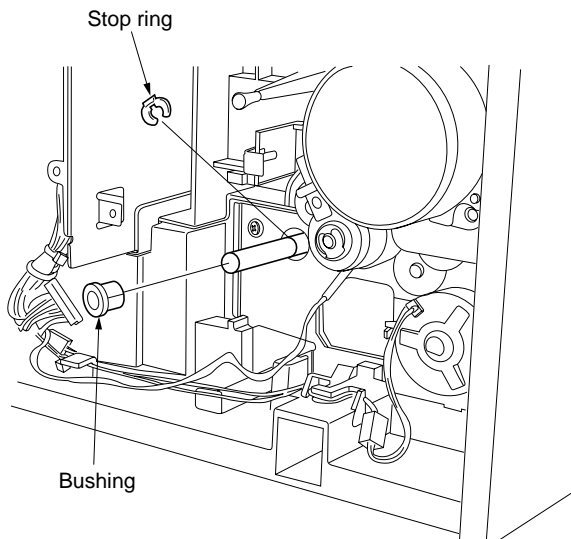

Figure 1-6-3

2BT

5. Remove the paper feed shaft unit from the lower front side of the machine.

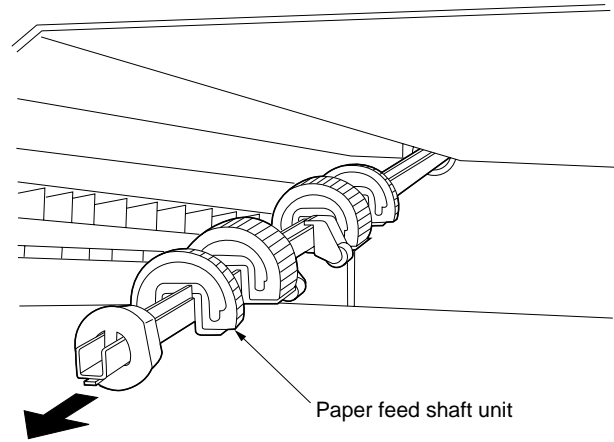

Figure 1-6-4

6. Remove the screw holding each of the paper feed pulleys and then the pulleys.
7. Replace the paper feed pulleys and refit all the removed parts.
 - Before returning the drawer, turn the main switch on.
 - When refitting the paper feed clutch, the stopper of the paper feed clutch must be firmly into the groove of the machine.

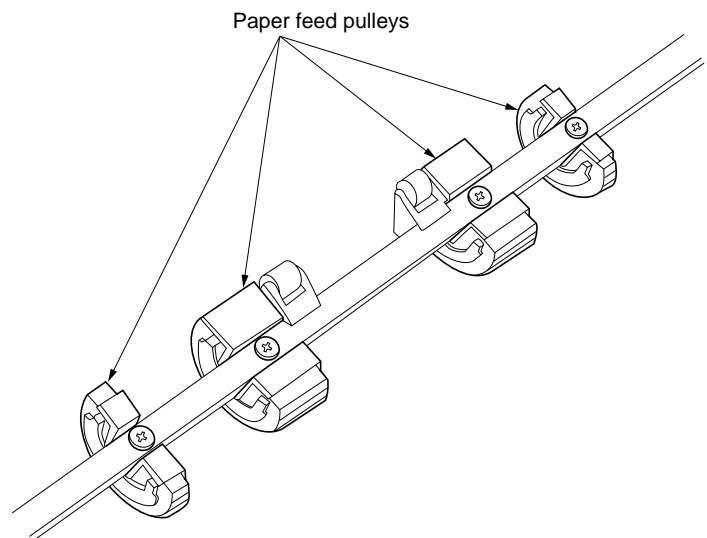

Figure 1-6-5

(2) Detaching and refitting the bypass paper feed pulley

Follow the procedure below to replace the bypass paper feed pulley.

Procedure

1. Remove the printer cover, rear cover and left cover.
2. Remove the image formation unit (see page 1-6-27).
3. Remove the fixing unit (see page 1-6-34).
4. Remove the screw and then the fulcrum pin.

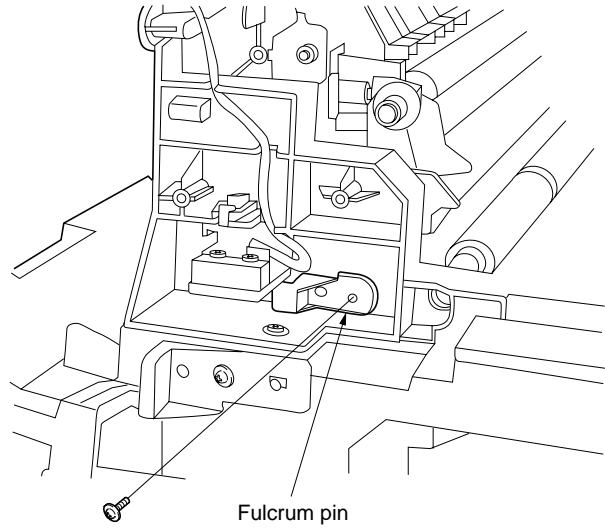
**Figure 1-6-6**

5. Remove the paper conveying unit.

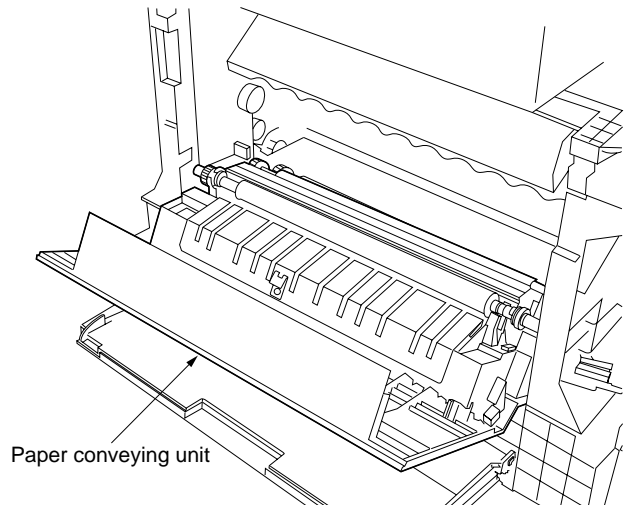
**Figure 1-6-7**

6. Remove the three screws holding the bypass cover and then the cover.

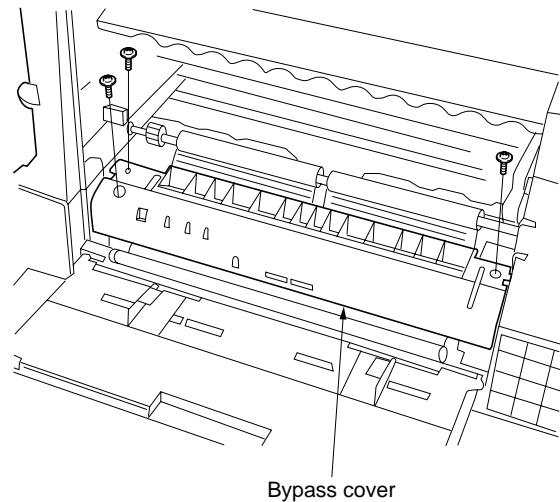
**Figure 1-6-8**

2BT

7. Remove the stop ring and then the bypass paper feed clutch.

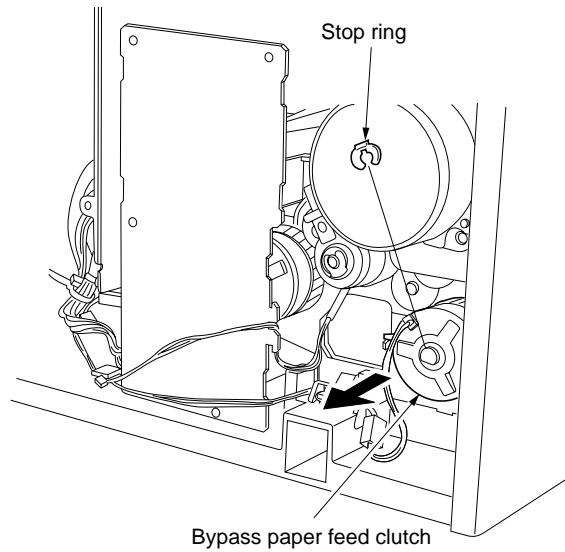

Figure 1-6-9

8. Remove the stop ring and bushing holding the bypass paper feed shaft unit and then the unit.

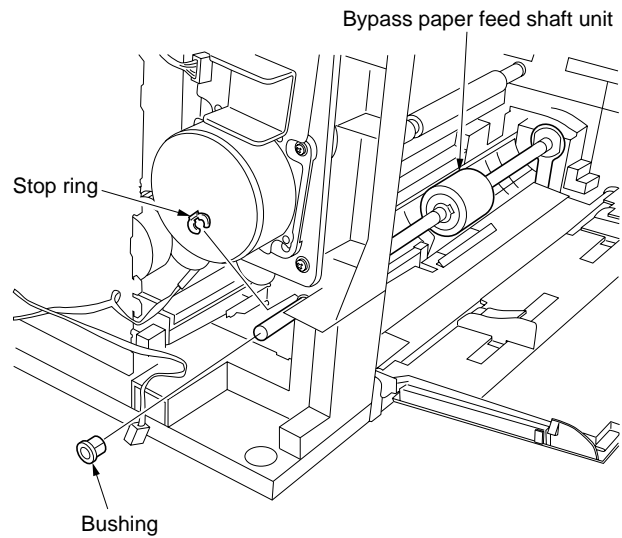

Figure 1-6-10

9. Remove the grounding plate, bushing and stop ring and then the bypass paper feed pulley.

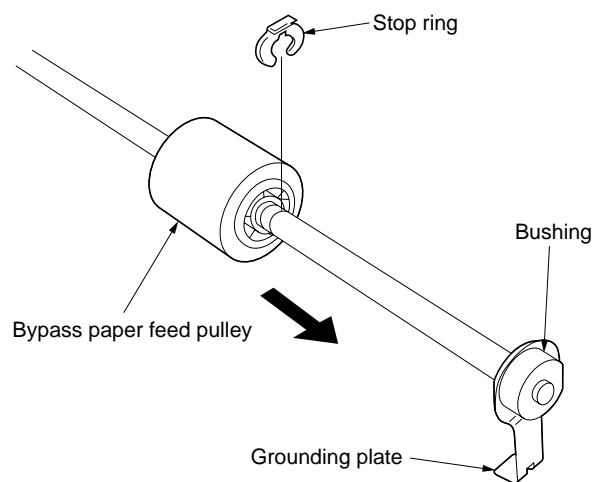

Figure 1-6-11

10. Replace the bypass paper feed pulley and refit all the removed parts.
 - Refit the bypass paper feed pulley so that the one-way clutch is machine rear.
 - When refitting the bypass paper feed shaft unit, check that the hole in the grounding plate is inserted over the projection under the bypass lift plate.
 - When refitting the paper feed clutch, the stopper of the paper feed clutch must be firmly into the groove of the machine.

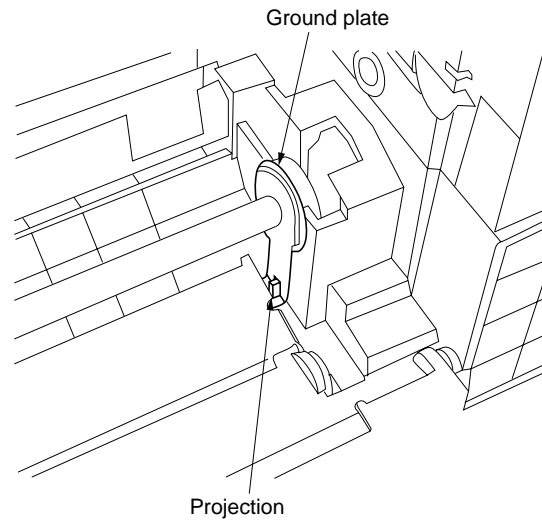

Figure 1-6-12

(3) Adjustment after roller and clutch replacement

Perform the following adjustment after refitting rollers and clutches.

(3-1) Adjusting the leading edge registration of image printing

Make the following adjustment if there is a regular error between the leading edges of the copy image and original.

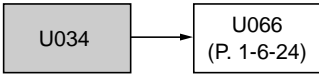

Caution:

Check the copy image after the adjustment. If the image is still incorrect, perform the above adjustments in maintenance mode.

Procedure

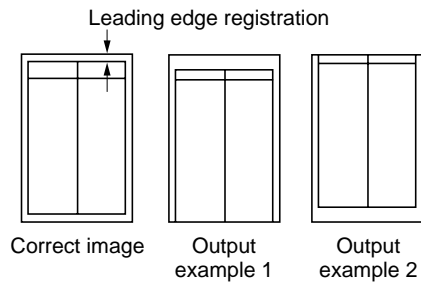
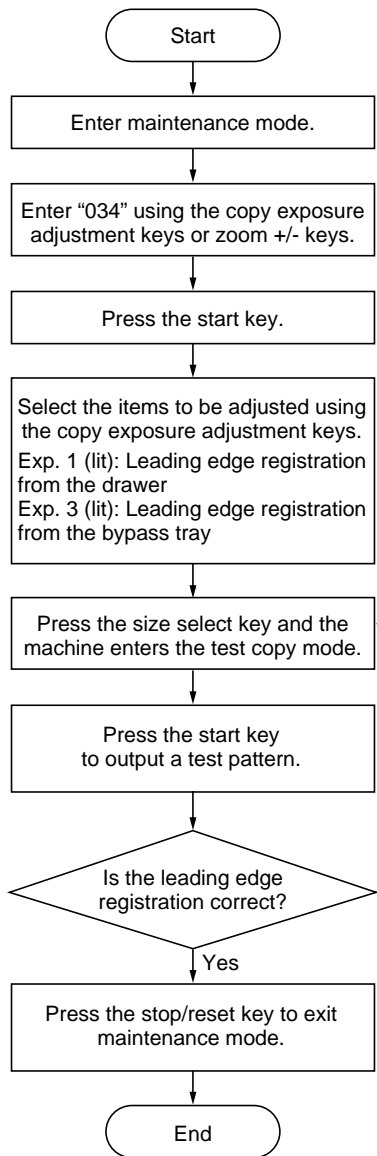
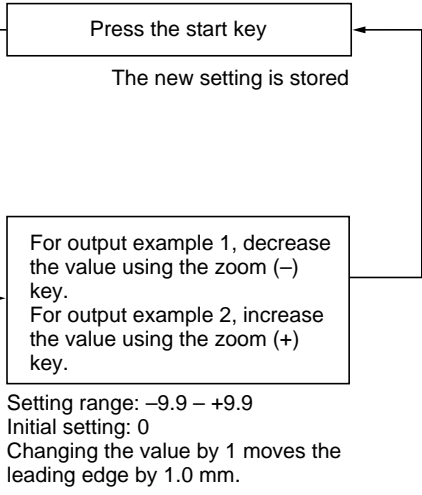
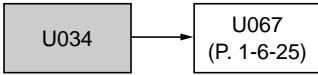

Figure 1-6-13



(3-2) Adjusting the center line of image printing

Make the following adjustment if there is a regular error between the center lines of the copy image and original when paper is fed from the drawer.



Caution:

Check the copy image after the adjustment. If the image is still incorrect, perform the above adjustments in maintenance mode.

Procedure

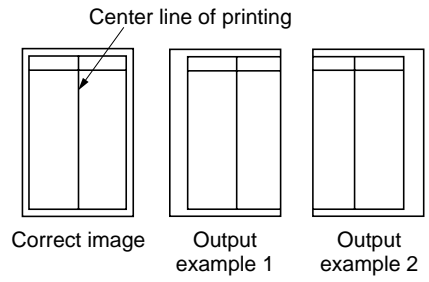
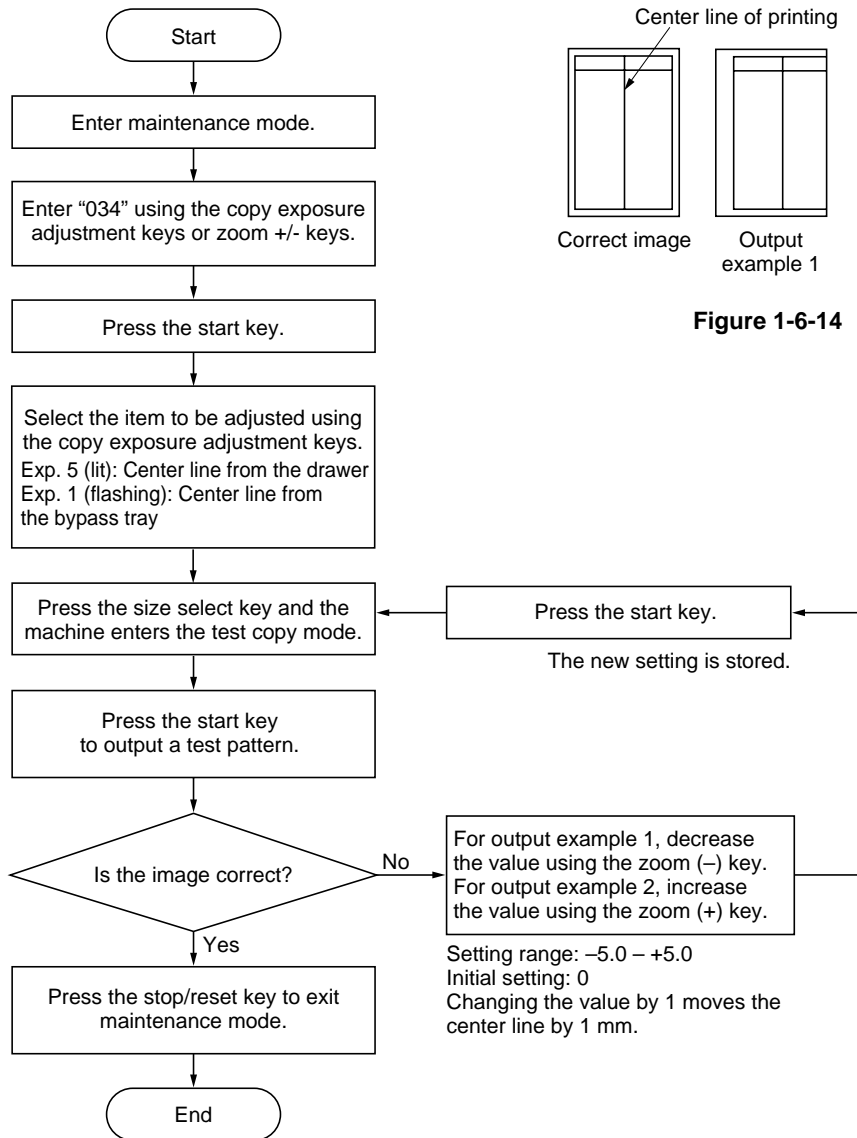
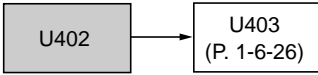

Figure 1-6-14

(3-3) Adjusting the margins for printing

Make the following adjustment if the margins are not correct.



Caution:

Check the copy image after the adjustment. If the margins are still incorrect, perform the above adjustments in maintenance mode.

Procedure

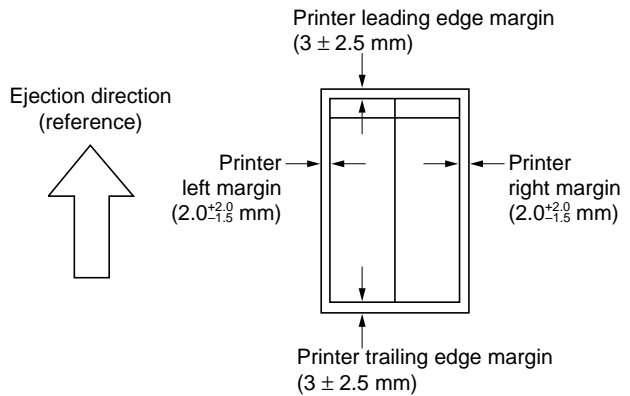
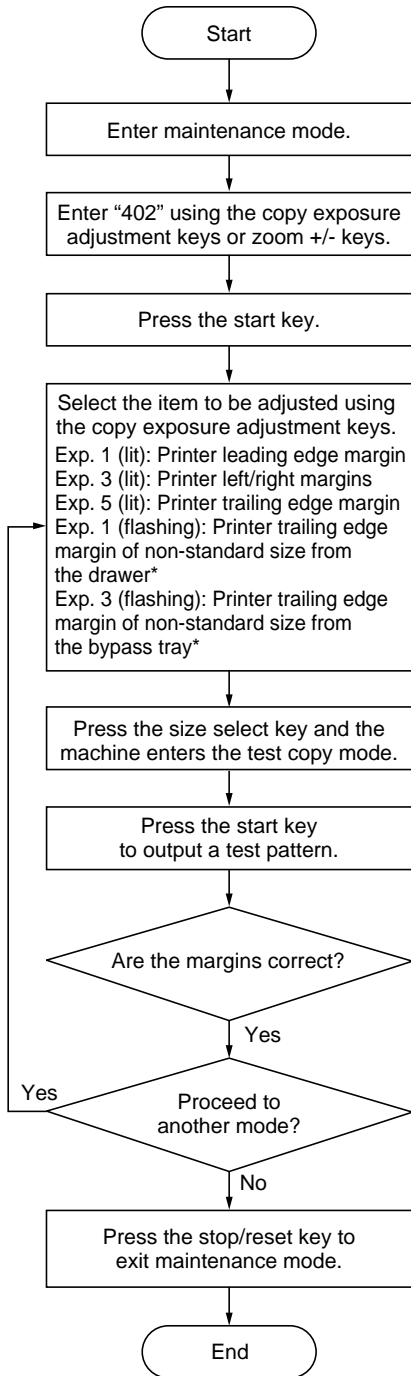

Figure 1-6-15

* Amount of image loss (msec) after the registration switch turns off

Setting range (initial setting/change in value per step)
 Printer leading edge margins: 0 – +10 (3/0.5 mm)
 Printer left/right margin: –5 – +10 (2.5/0.5 mm)
 Printer trailing edge margin: –5 – +10 (4.5/0.5 mm)
 Printer trailing edge margin of non-standard size from the drawer: 0 – +400 (214/1 msec)
 Printer trailing edge margin of non-standard size from the bypass tray: 0 – +400 (200/1 msec)

(3-4) Adjusting the amount of slack in the paper

Make the following adjustment if the leading edge of the copy image is missing or varies randomly, or if the copy paper is Z-folded.

Procedure

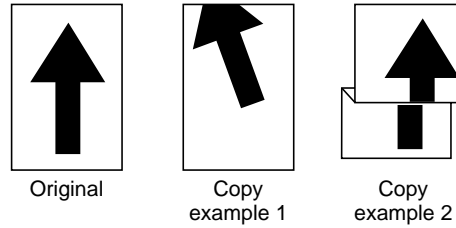
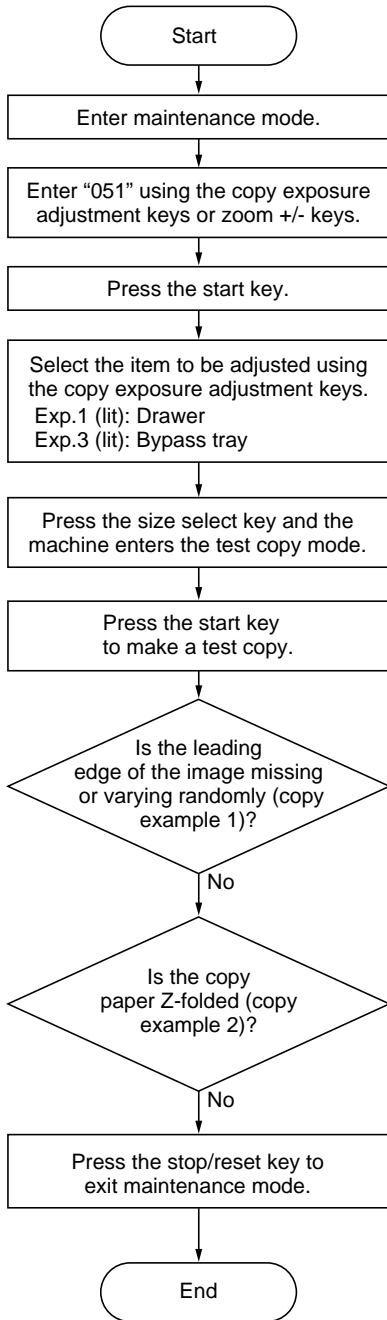

Figure 1-6-16

Setting range: -95 – +95
 Initial setting: 0
 Changing the value by 1 changes the amount of slack by 0.32 mm.
 The greater the value, the larger the amount of slack;
 the smaller the value, the smaller the amount of slack.

1-6-3 Optical section

(1) Detaching and refitting the exposure lamp

Replace the exposure lamp as follows.

Procedure

1. Remove the printer cover and right cover and then the contact glass.

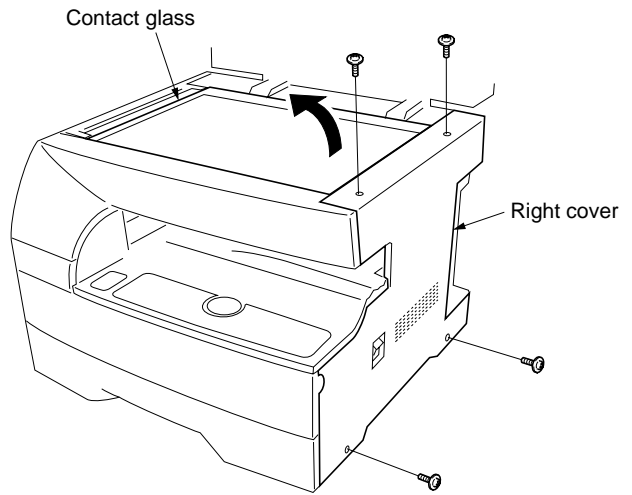

Figure 1-6-17

2. Move the mirror 1 frame to the cutouts of the machine.
3. Detach the exposure lamp connector from the inverter PCB.

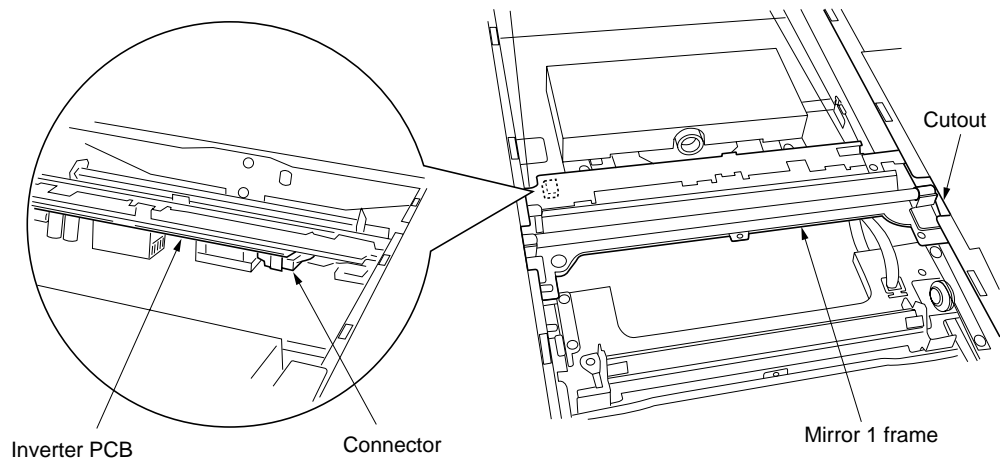

Figure 1-6-18

4. Remove the two screws holding the exposure lamp and then the lamp.
5. Replace the exposure lamp and refit all the removed parts.

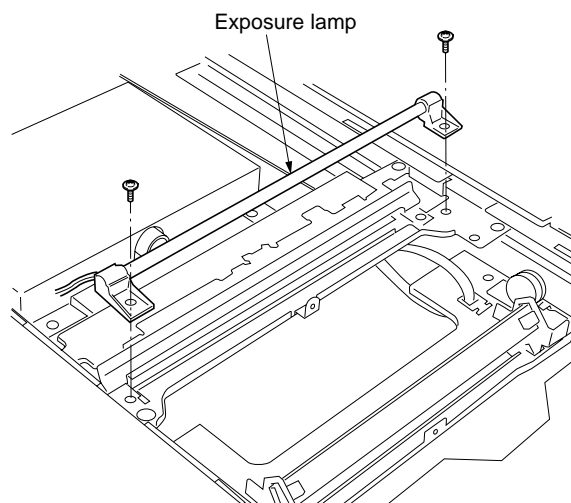

Figure 1-6-19

(2) Detaching and refitting the scanner wires

Take the following procedure when the scanner wires are broken or to be replaced.

(2-1) Detaching the scanner wires

Procedure

1. Remove the right cover, left cover, rear cover, upper front cover and contact glass.
2. Move the mirror 1 frame to the cutouts of the machine.
3. Detach the inverter wire from the inverter PCB.

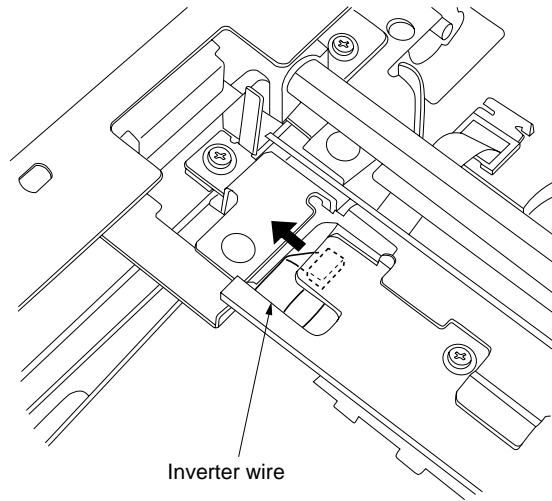

Figure 1-6-20

4. Remove the screw holding each of the front and rear wire retainers.
5. Remove the mirror 1 frame from the scanner unit.

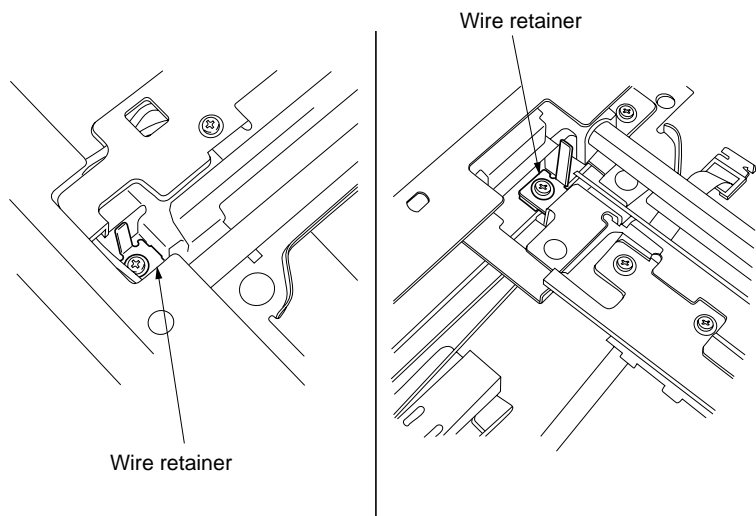

Figure 1-6-21

6. Unhook the round terminal of the scanner wire from the scanner tension spring on the right side of the scanner unit.
7. Remove the scanner wire.

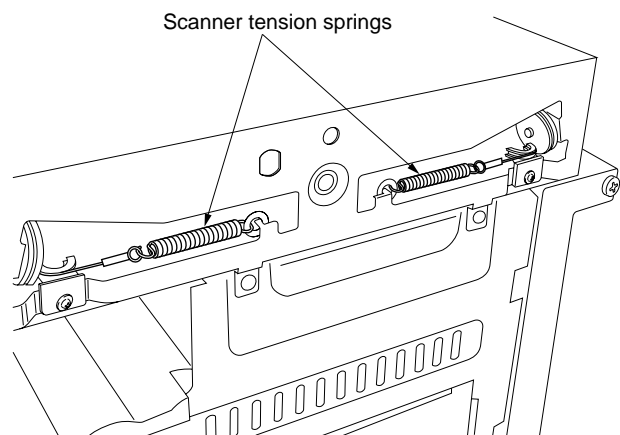

Figure 1-6-22

(2-2) Fitting the scanner wires

Caution:

When fitting the wires, be sure to use those specified below.
 Machine front: P/N 2A11208 (gray)
 Machine rear: P/N 2A11209 (black)

Fitting requires the following tools:
 Two frame securing tools (P/N 2A168080)

Procedure

1. Remove the two screws holding the motor retainer grounding plate and then the plate. Remove the four screws holding the scanner motor unit and then the unit.

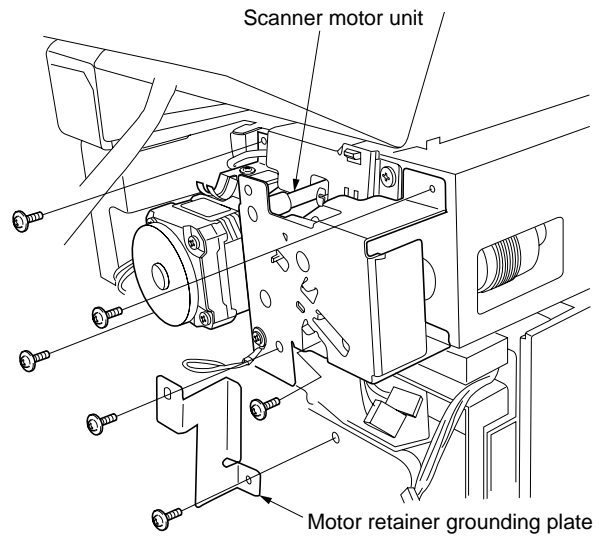

Figure 1-6-23

2. Remove the screw and the gear.

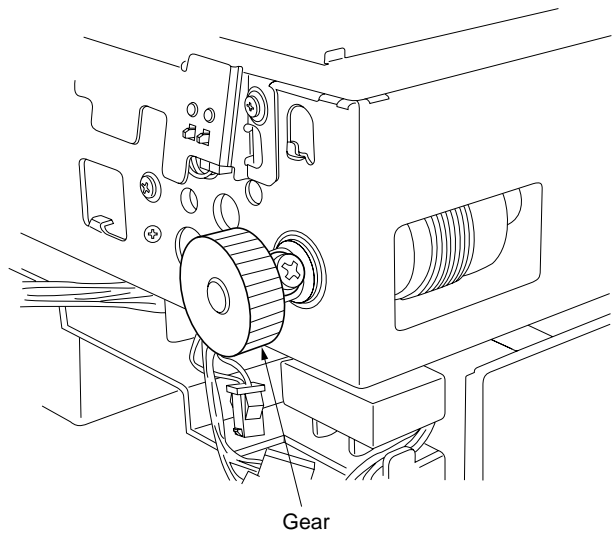

Figure 1-6-24

3. Remove the each E ring and bushing from the front and rear of the scanner wire drum shaft and then remove the scanner wire drum shaft from the scanner unit.

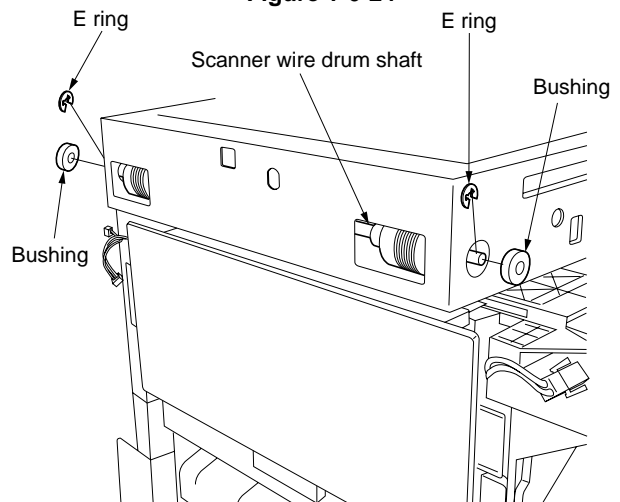

Figure 1-6-25

4. Insert the locating ball on each of the scanner wires into the hole in the respective scanner wire drum and wind the scanner wire two turns inward and eight turns outward.
 - Use the gray wire at the machine front and the black wire at the machine rear.
5. Refit the scanner wire drum shaft to the scanner unit.
 - Make sure that the locating balls point downward.

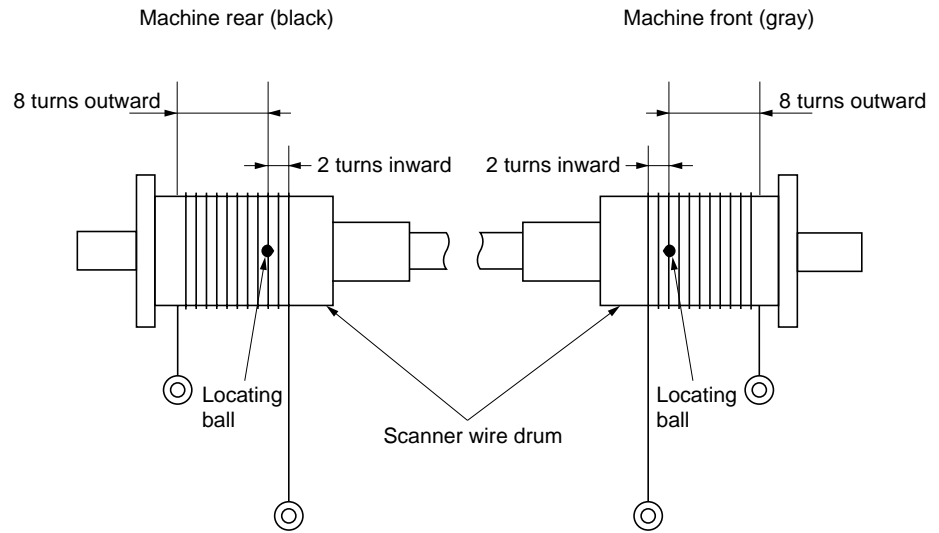

Figure 1-6-26

6. Insert the two frame securing tools into the positioning holes at the front and rear of the scanner unit to pin the mirror 2 frame in position.

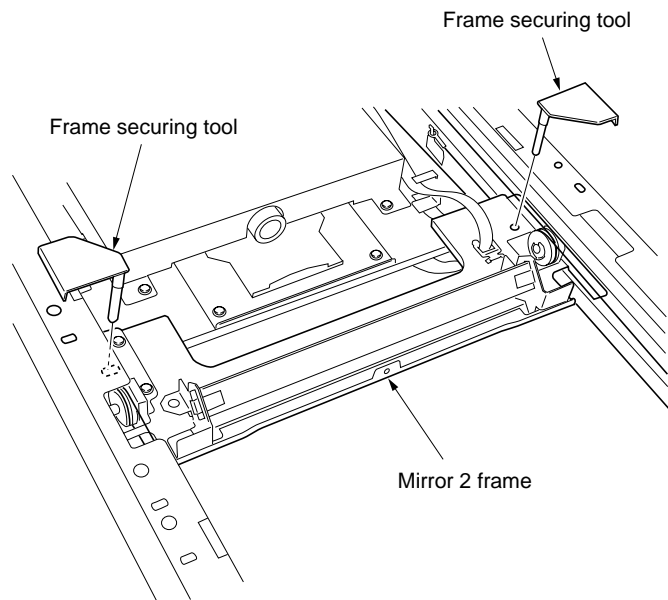

Figure 1-6-27

7. Loop the scanner wires around the outer grooves in the pulleys on the mirror 2 frame, winding from above to below. ①
8. Hook the round terminals onto the catches inside the scanner unit. ②

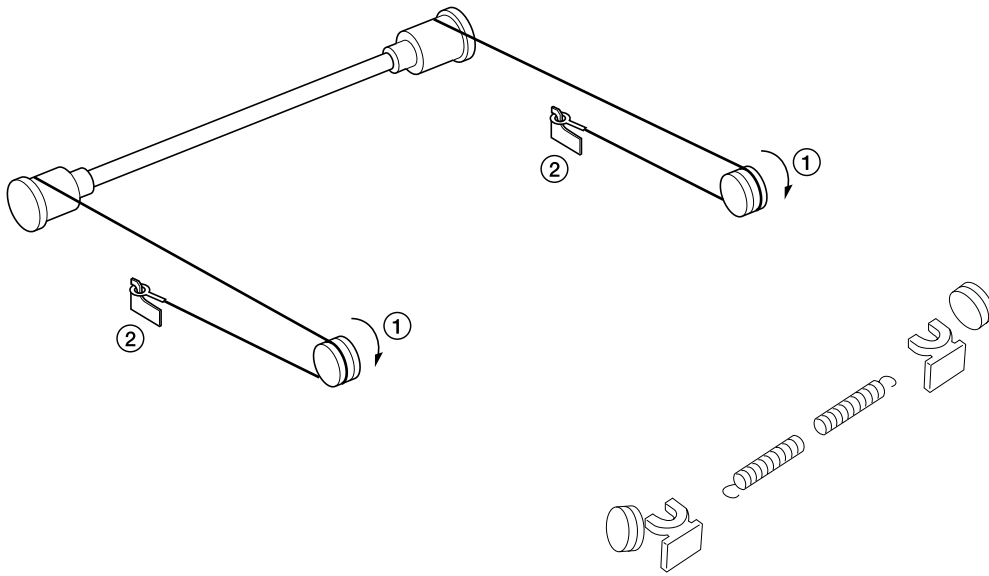

Figure 1-6-28

9. Loop the outer ends of the scanner wires around the grooves in the scanner wire pulleys at the right of the scanner unit, winding from below to above. ③
10. Loop the scanner wires around the inner grooves in the pulleys on the mirror 2 frame, winding from above to below. ④
11. Wind the scanner wires around the grooves in the scanner wire guides at the right of the scanner unit. ⑤
12. Hook the round terminals onto the scanner tension springs. ⑥

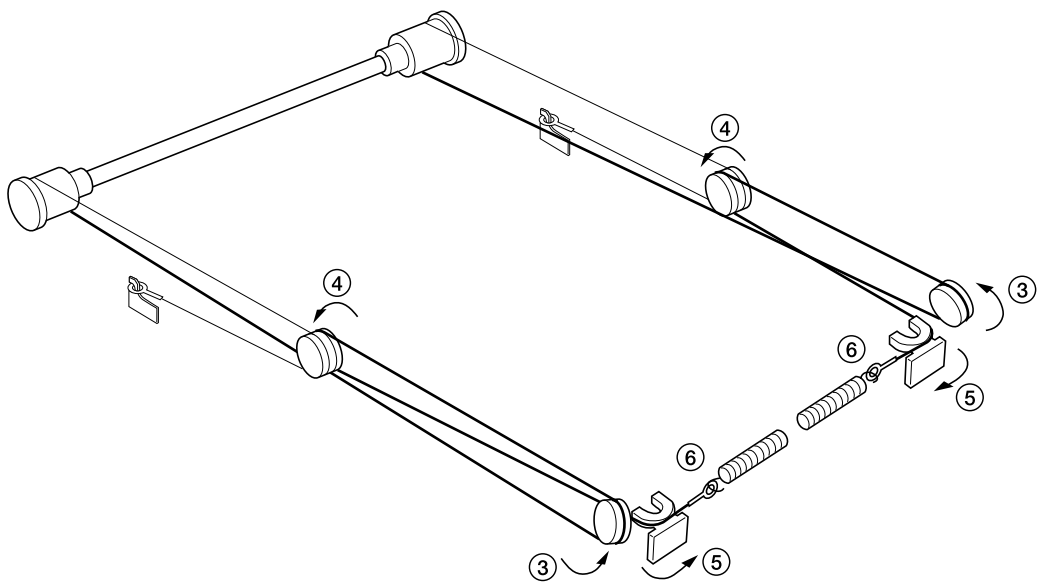

Figure 1-6-29

13. Remove the scanner wire stoppers and frame securing tools.
14. Gather the scanner wires toward the locating balls.
15. Move the mirror 2 frame from side to side to correctly locate the wires in position.
16. Refit all the removed parts.

(3) Detaching and refitting the laser scanner unit

Take the following procedure when the laser scanner unit is to be checked or replaced.

Procedure

1. Open the front cover and remove the waste toner tank and toner container.
2. Remove the printer cover and right cover.
3. Detach the two connector of the operation unit.

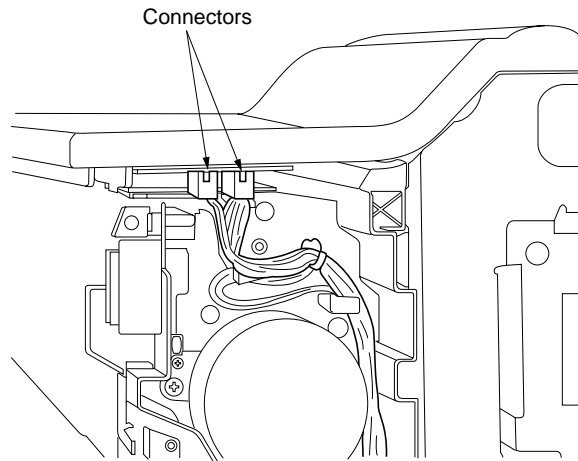

Figure 1-6-30

4. Remove the two screws holding the eject tray and then the tray.

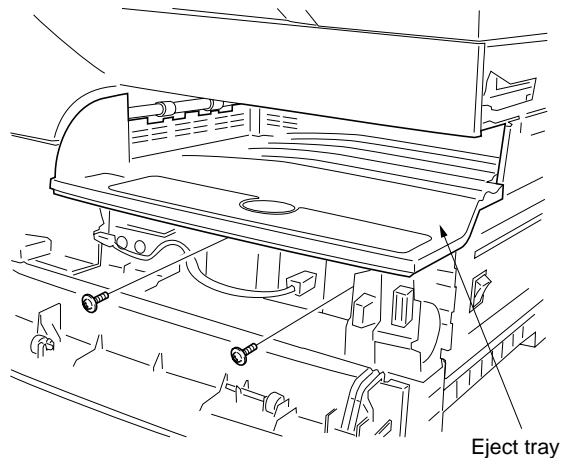

Figure 1-6-31

5. Remove the three screws holding the laser scanner unit.

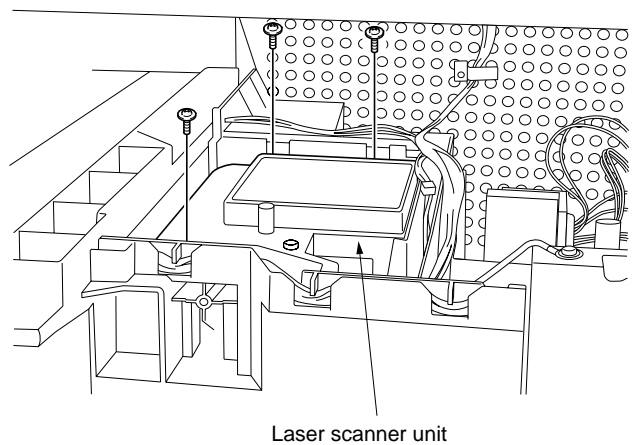
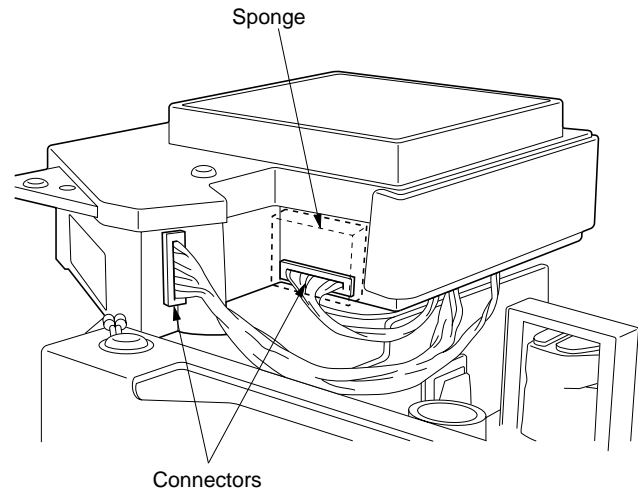

Figure 1-6-32

6. Detach the two connector and remove the laser scanner unit.
 - When removing the connector that is covered with a sponge, remove the sponge first.
7. Replace the laser scanner unit and refit all the removed parts.
Fit the sponge packing with the new scanner unit.
8. Run the maintenance item U042 to set the type of LSU. See the label on the LSU.

**Figure 1-6-33**

(4) Detaching and refitting the ISU (reference)

Take the following procedure when the ISU is to be checked or replaced.

Procedure

1. Remove the printer cover, right cover and contact glass.
2. Remove the rear cover and the shield cover.
3. Detaach connectors CN16 and CN17 on the main PCB.

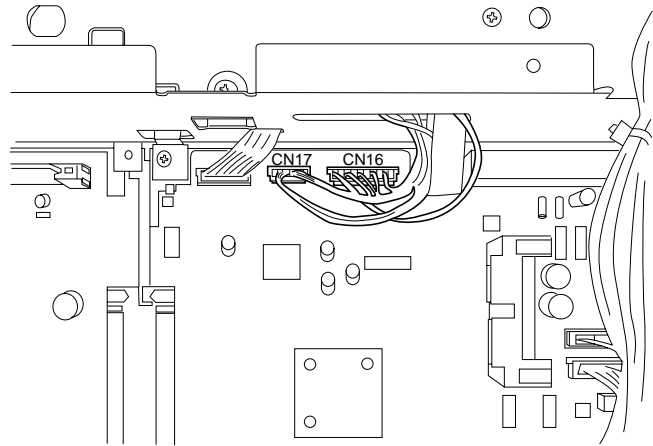

Figure 1-6-34

4. Remove the ISU cable plate.
5. Remove the four screws holding the ISU cover and then the cover.

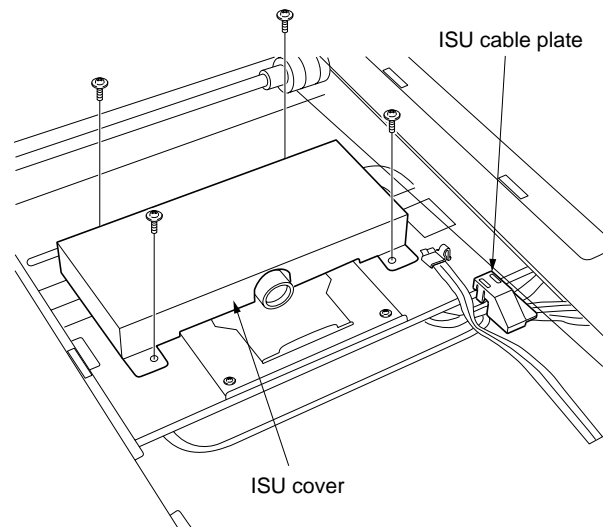

Figure 1-6-35

6. Remove the four screws holding the ISU and then the ISU.
7. Replace the ISU and refit all the removed parts.
8. Run maintenance items U065, U066 and U067 to adjust the copy image.

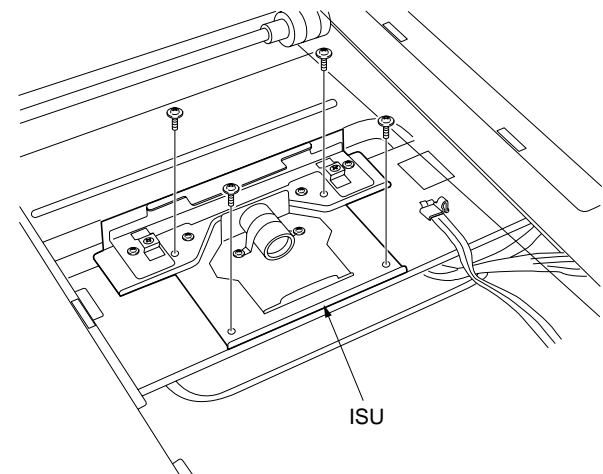

Figure 1-6-36

(5) Adjusting the longitudinal squareness (reference)

Perform the following adjustment if the copy image is longitudinally skewed (longitudinal squareness not obtained).

Caution:

- Adjust the amount of slack in the paper (page 1-6-11) first. Check for the longitudinal squareness of the copy image, and if it is not obtained, perform the longitudinal squareness adjustment.
- Before making the following adjustment, output a VTC-PG2 pattern in maintenance item U993 to use as the original for the adjustment.

Procedure

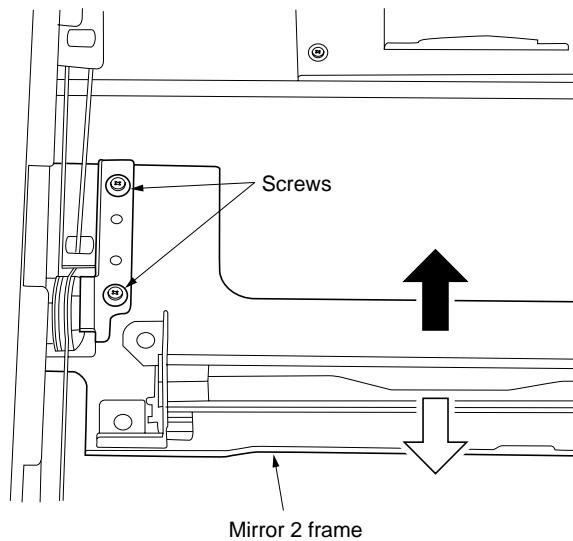
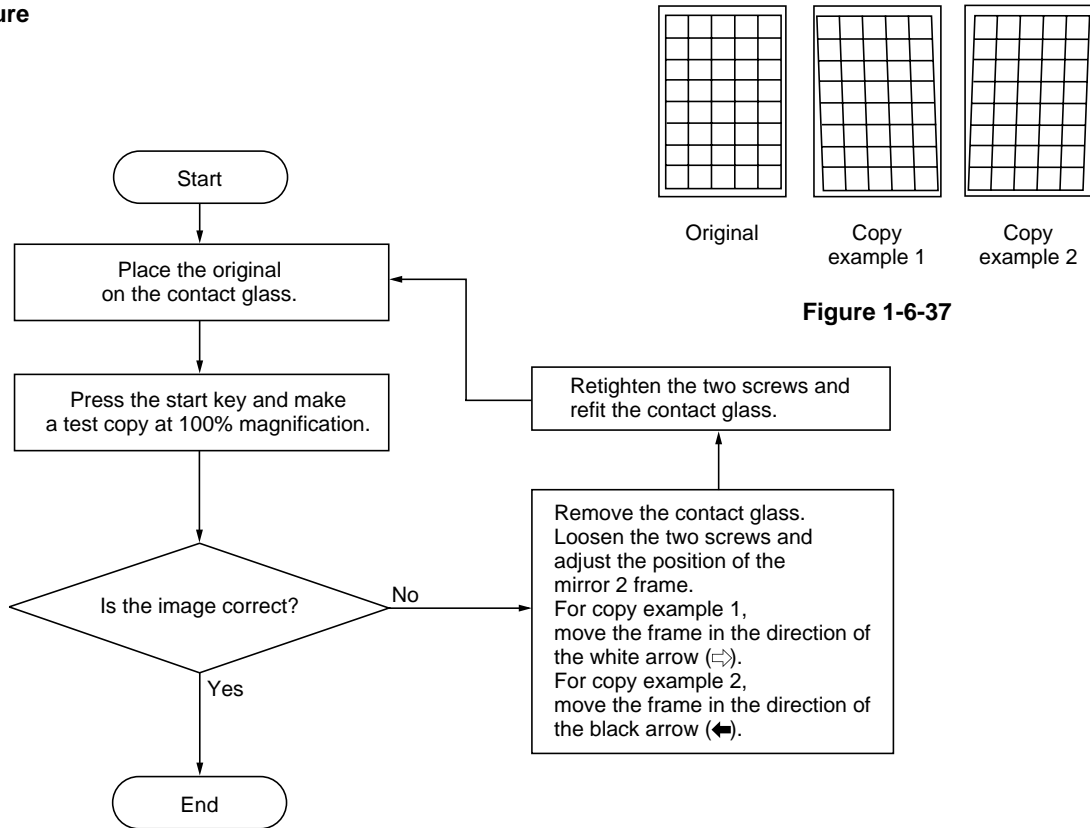
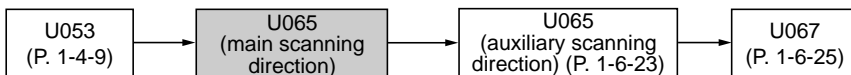

Figure 1-6-38

(6) Adjusting magnification of the scanner in the main scanning direction

Perform the following adjustment if the magnification in the main scanning direction is not correct.



Caution:

Before making the following adjustment, ensure that the above adjustments have been made in maintenance mode. Also, perform “(7) Adjusting magnification of the scanner in the auxiliary scanning direction” (page 1-6-23) and “(9) Adjusting the scanner center line” (page 1-6-25) after this adjustment.

Procedure

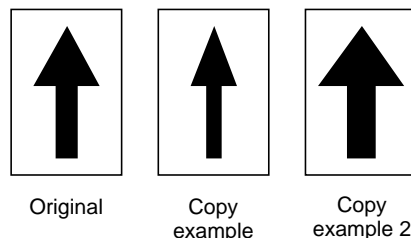
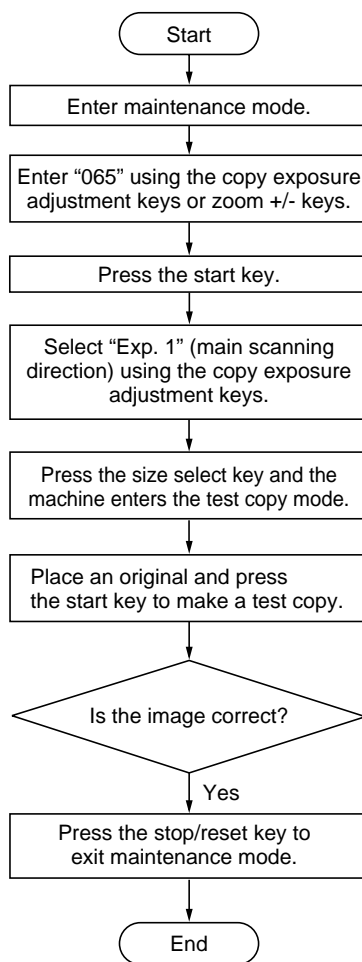
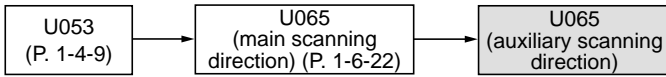

Figure 1-6-39

Setting range: -25 – +25
 Initial setting: 0
 Changing the value by 1 changes the magnification by 0.1%.
 Increasing the value makes the image wider, and decreasing it makes the image narrower.

(7) Adjusting magnification of the scanner in the auxiliary scanning direction

Perform the following adjustment if the magnification in the auxiliary scanning direction is not correct.



Caution:

Before making the following adjustment, ensure that the above adjustments have been made in maintenance mode.

Procedure

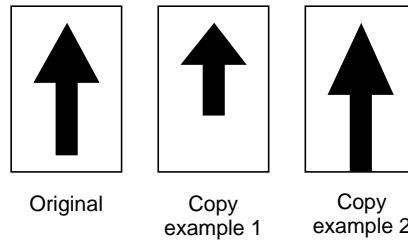
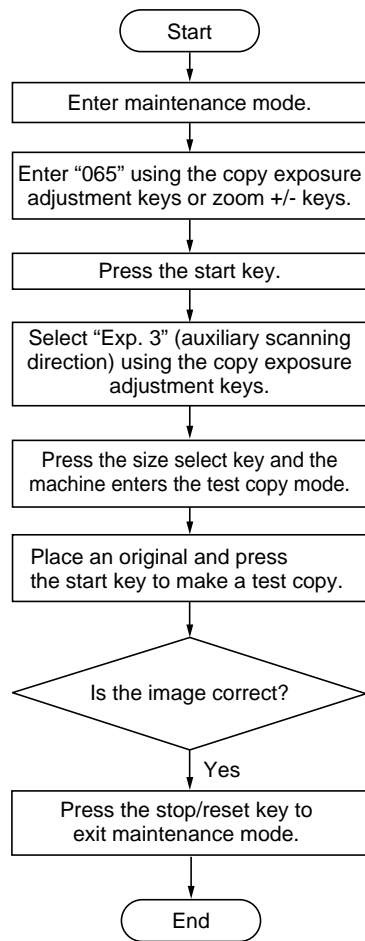

Figure 1-6-40

Press the start key.

The new setting is stored.

For copy example 1, increase the value using the zoom (+) key.
For copy example 2, decrease the value using the zoom (-) key.

Setting range: -25 – +25
Initial setting: 0
Changing the value by 1 changes the magnification by 0.1%.
Increasing the value makes the image longer, and decreasing it make the image shorter.

(8) Adjusting the scanner leading edge registration

Perform the following adjustment if there is regular error between the leading edges of the copy image and original.

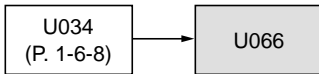

Caution:

Before making the following adjustment, ensure that the above adjustments have been made in maintenance mode.

Procedure

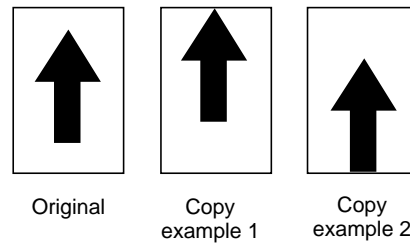
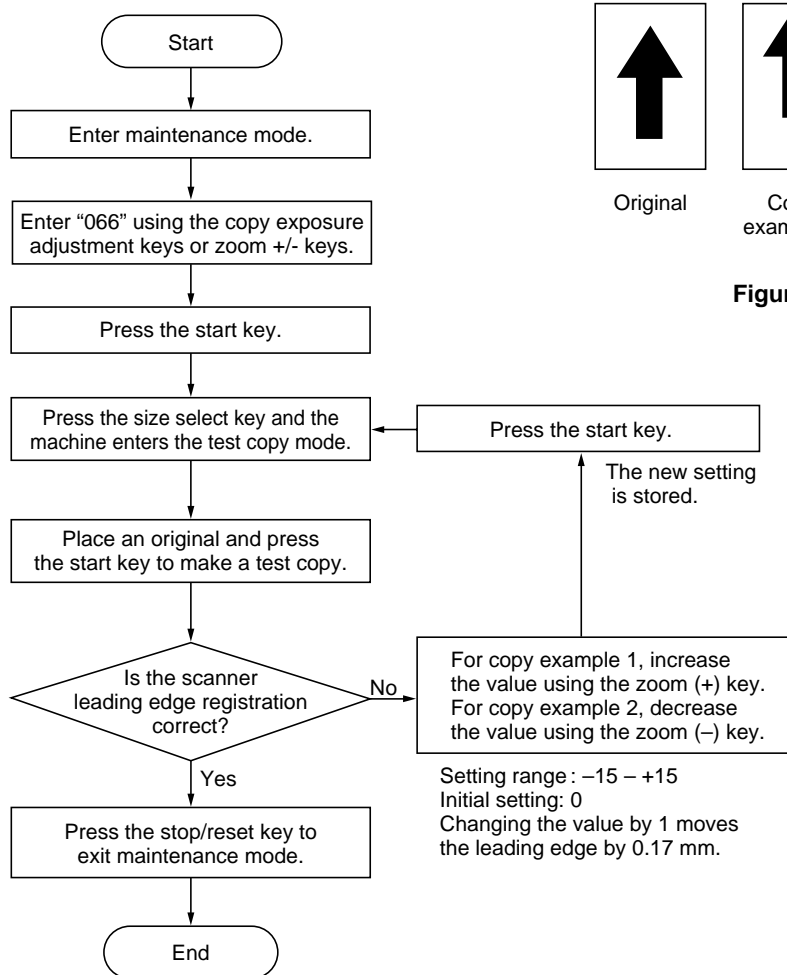
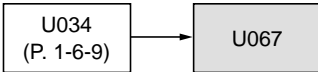

Figure 1-6-41

Setting range : -15 – +15
 Initial setting: 0
 Changing the value by 1 moves the leading edge by 0.17 mm.

(9) Adjusting the scanner center line

Perform the following adjustment if there is a regular error between the center lines of the copy image and original.



Caution:

Before making the following adjustment, ensure that the above adjustments have been made in maintenance mode.

Procedure

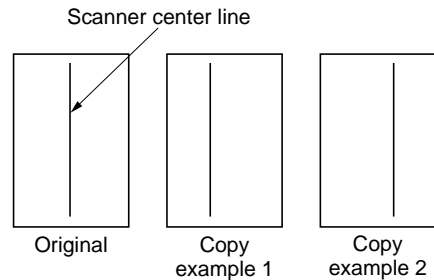
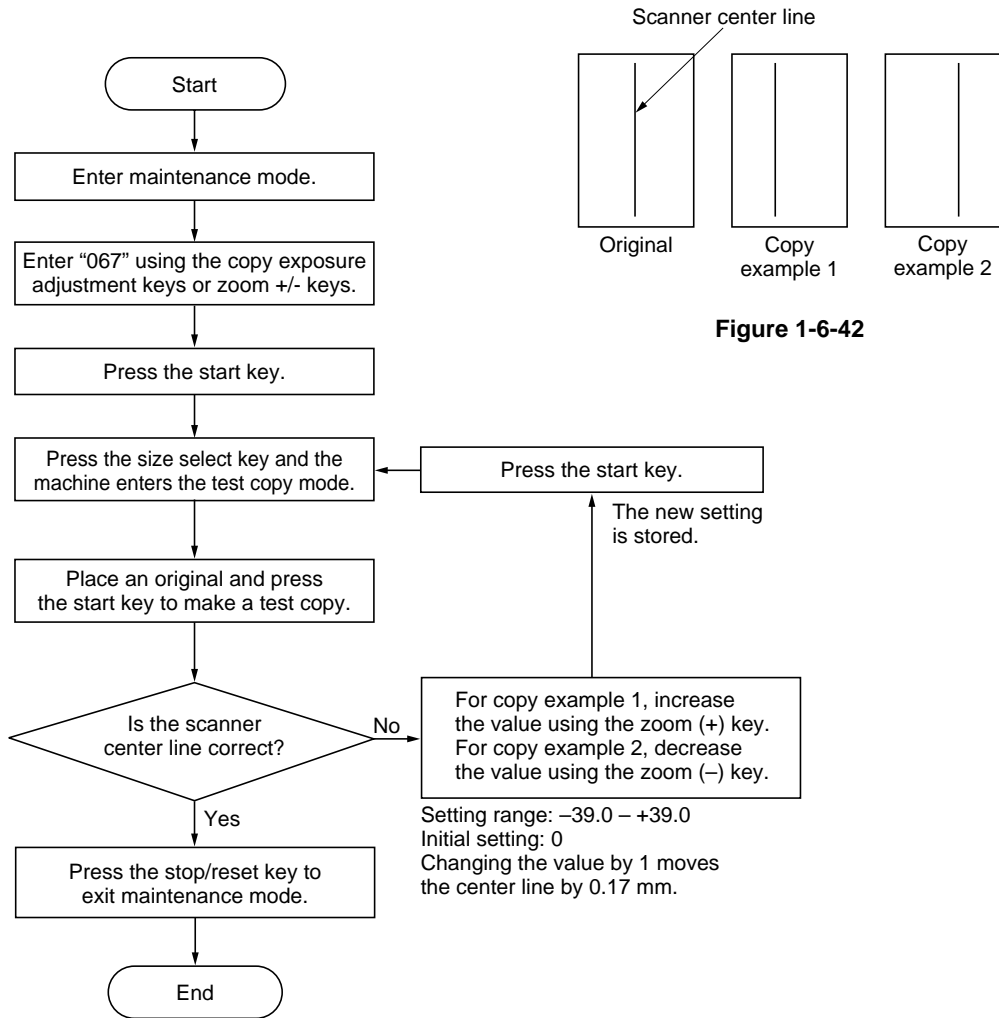
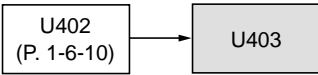

Figure 1-6-42

(10) Adjusting the margins for scanning an original on the contact glass

Perform the following adjustment if the margins are not correct.



Caution:

Before making the following adjustment, ensure that the above adjustments have been made in maintenance mode.

Procedure

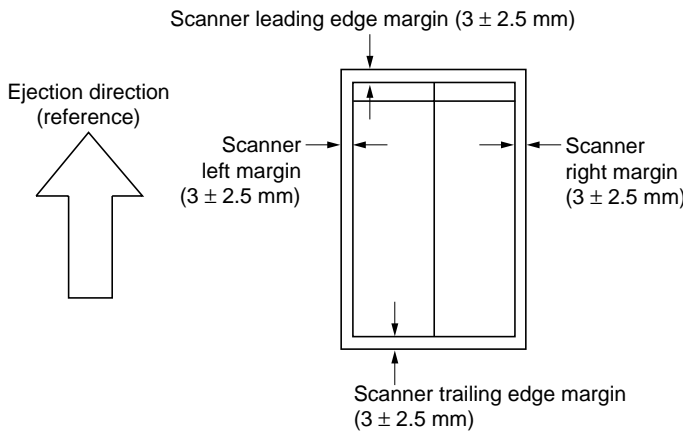
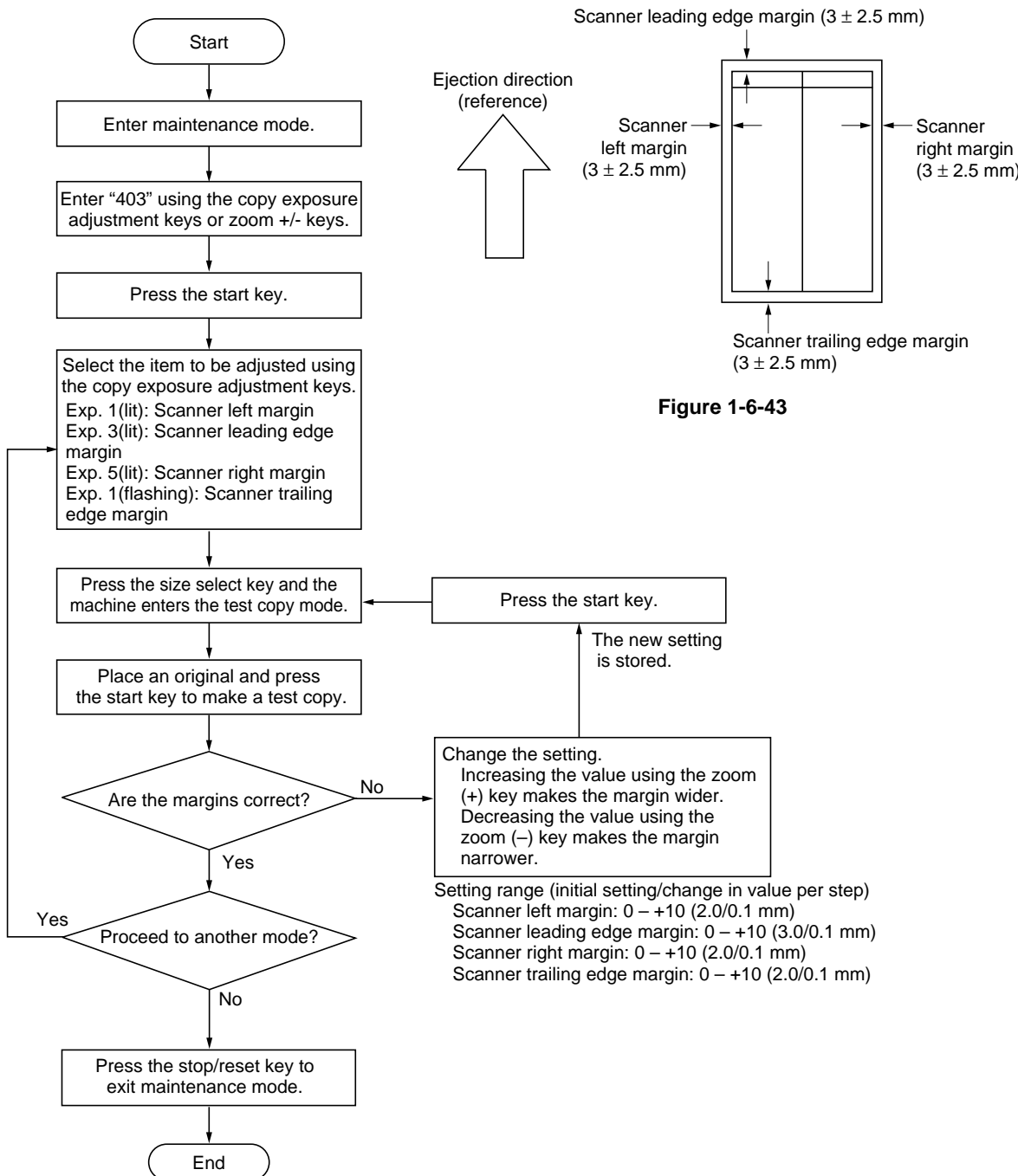

Figure 1-6-43

Setting range (initial setting/change in value per step)
 Scanner left margin: 0 – +10 (2.0/0.1 mm)
 Scanner leading edge margin: 0 – +10 (3.0/0.1 mm)
 Scanner right margin: 0 – +10 (2.0/0.1 mm)
 Scanner trailing edge margin: 0 – +10 (2.0/0.1 mm)

1-6-4 Image formation section

(1) Detaching and refitting the image formation unit

Follow the procedure below to replace or check the image formation unit.

Prucedure

1. Pull the drawer out and open the front cover, bypass tray and paper conveying unit.
2. Remove the waste toner tank and toner container.
3. Remove the two screws holding the waste toner tank cover and then the cover.
4. Remove the screw holding the developing retainer and then the retainer.

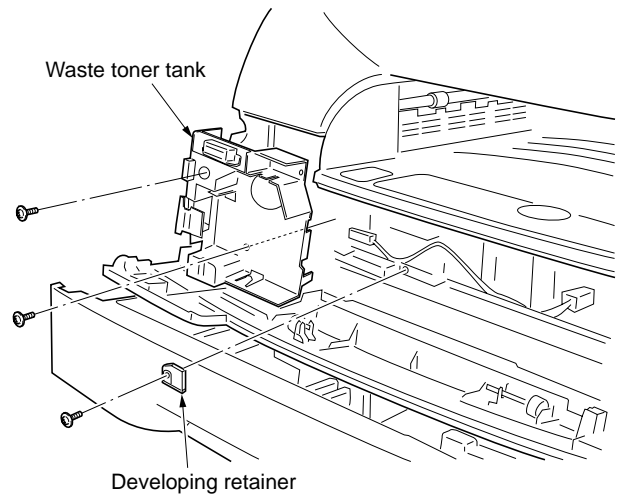

Figure 1-6-44

5. Remove the two screws and datach the connector and remove the image formation unit.

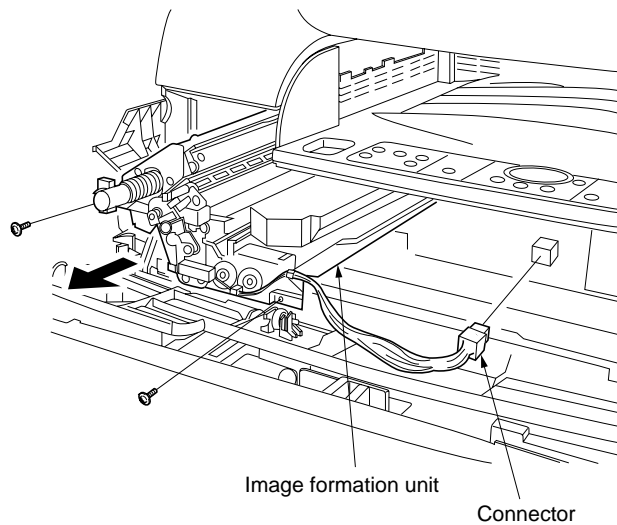

Figure 1-6-45

(2) Detaching and refitting the main charger unit

Follow the procedure below to replace the charger assembly.

Prucedure

1. Remove the image formation unit (see page 1-6-27).
2. Remove the screw holding the main charger assembly and then the assembly.
3. Replace the main charger unit and refit all the removed parts.
 - When fitting the main charger unit, hold it down and fit it close to the cleaning unit.

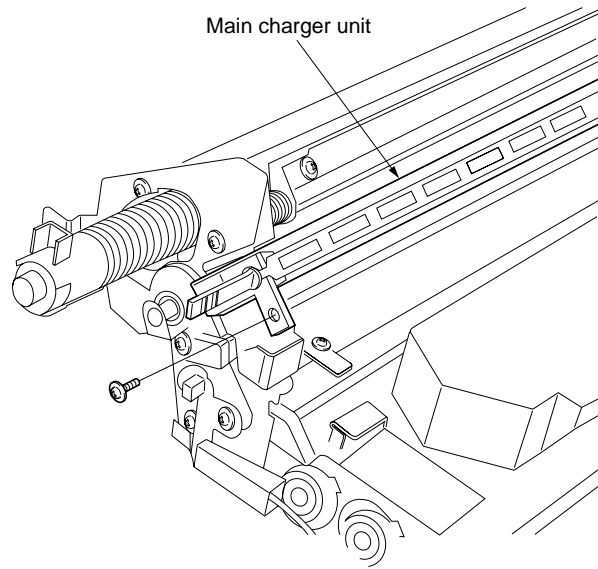

Figure 1-6-46

(3) Detaching and refitting the drum

Follow the procedure below to replace the drum.

Cautions:

- Avoid direct sunlight or strong light when detaching and fitting the drum.
- When removing the drum, spread paper underneath as there is a possibility of toner spill. Toner spill can be reduced by inserting an approximately 20-mm thick pad under the image formation unit toward the developing section and removing the drum with the unit slightly tilted.
- Hold the drum at the ends and never touch the drum surface.
- After removing the drum, keep it in the drum case or storage bag to protect the surface from light.

Prcedure

1. Remove the image formation unit (see page 1-6-27).
2. Remove the main charger unit (see page 1-6-28).
3. Remove the four screw and blade spring, and then open the cleaning unit.
 - Slide the cleaning blade back and forth and insert an approximately 4 to 4.5-mm thick spacer between the retainer at the rear of the cleaning unit and the housing.

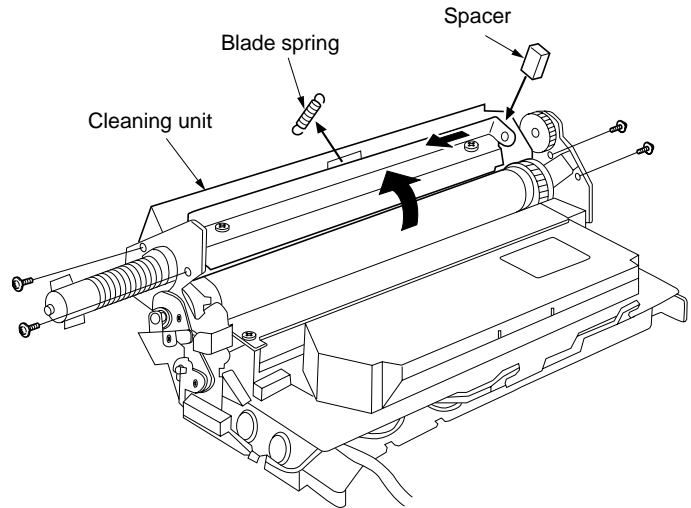

Figure 1-6-47

4. Remove the screw holding the drum grounding plate and then the plate.
5. Remove the E ring from the drum shaft.

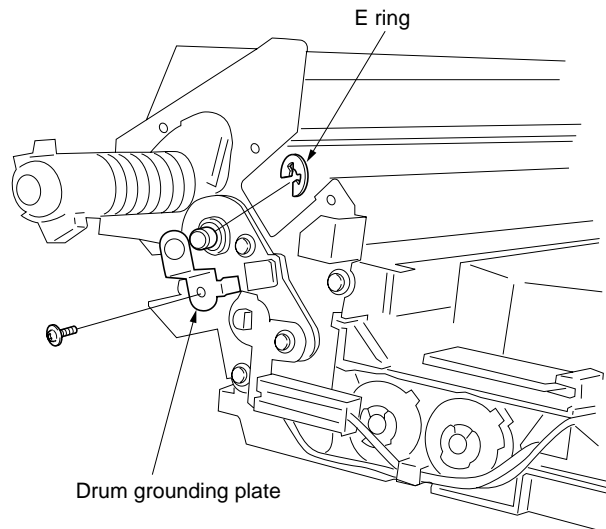

Figure 1-6-48

6. Remove the screw holding the upper developing seal and then the seal.

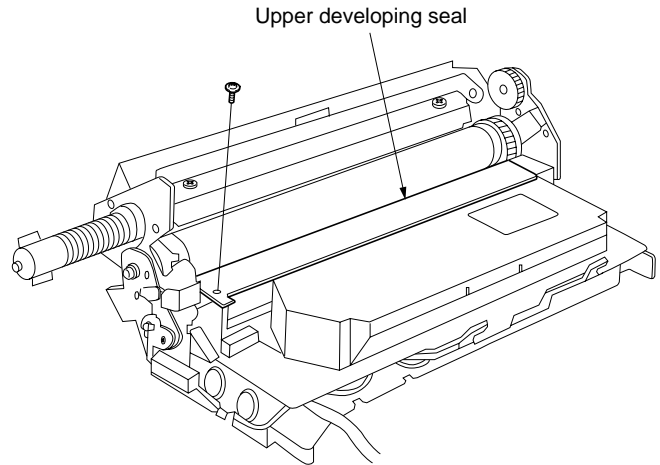

Figure 1-6-49

7. Pull the drum shaft out and remove the drum.
 - Detach the drum horizontally.
8. Replace the drum and refit all the removed parts.
 - When replacing the drum, insert a sheet of paper between the drum and developing roller to prevent damage to the drum.
 - Check the letter indicating the drum type printed on the new drum flange.
 - Securely insert the drum shaft as far as it will go. When turning the drum shaft, turn it in the direction indicated by the arrow marked on the image formation unit frame.
 - Rotate the drum in its rotational direction and check that the cleaning blade does not flip up.
9. After replacing the drum, run maintenance items below.
 - U109 "Setting the drum type " (set to the drum type printed on the new drum flange)
 - U110 "Checking/clearing the drum count"(clear the drum count)
 - U111 "Checking/clearing the drum drive time" (clear the value)

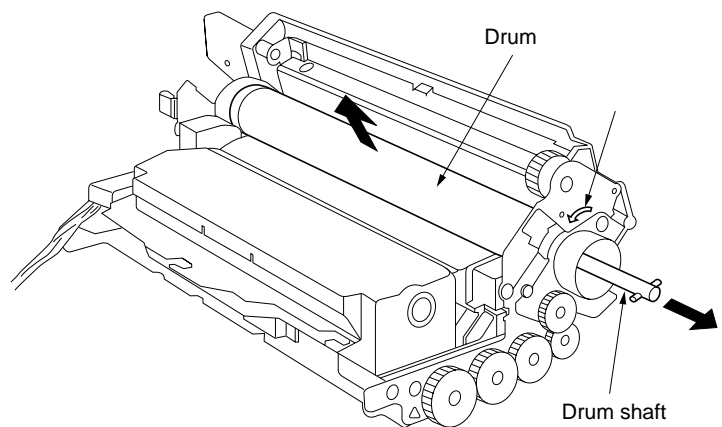

Figure 1-6-50

(4) Detaching and refitting the cleaning blade

Follow the procedure below to replace the cleaning blade.

Procedure

1. Remove the image formation unit (see page 1-6-27).
2. Remove the main charger unit (see page 1-6-28).
3. Remove the drum (see page 1-6-29).
4. Remove the two screws and remove the cleaning blade.

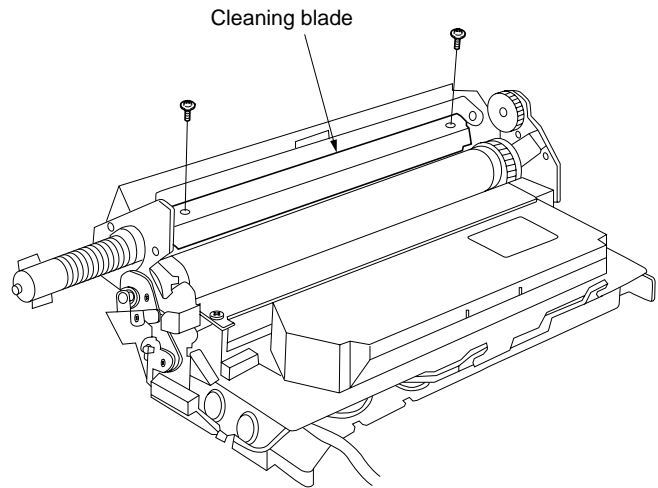
**Figure 1-6-51**

5. Replace the cleaning blade and refit all the removed parts.
 - Apply toner or white powder to the edge of the new cleaning blade.
 - After fitting the cleaning blade, slide it to the right and left once and check that the right and left edges of the blade do not ride over or enter under the seal.
 - Rotate the drum shaft in the direction of the arrow marked on the image formation unit frame and check that the cleaning blade does not flip up.

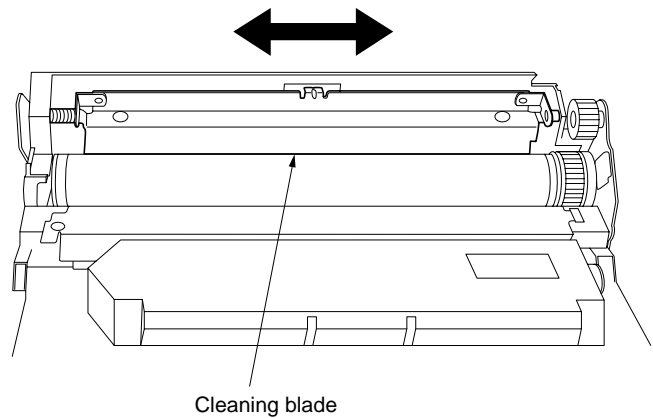
**Figure 1-6-52**

(5) Replace the developer

Follow the procedure below to replace the developer.

Prucedure

1. Remove the image formation unit (see page 1-6-27).
2. Remove the screw and washer. While lifting the hooks upward, slide the developing section cover until removed.
3. Replace the developer and refit all the removed parts.
 - When disposing of the developer, tilt the image formation unit in the direction of A shown in the diagram and rotate the developing spiral gear.
 - Never turn the magnet roller when the drum is installed.
 - When refitting the developing section cover, make sure that the cover and the three hooks of the housing engage securely.
4. Run the maintenance item U130 to set the initial setting for the developer.

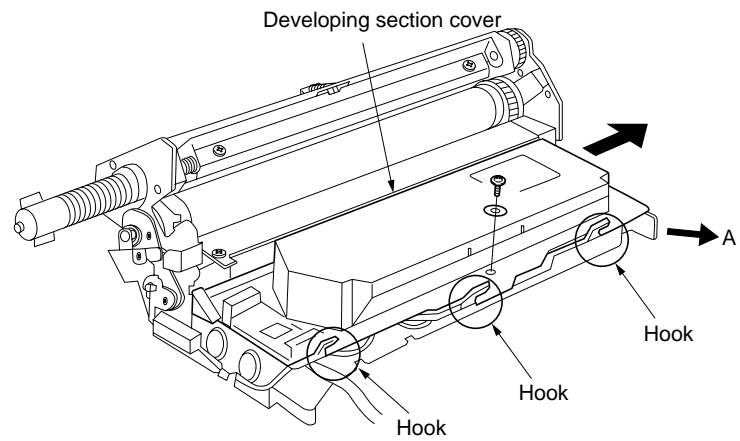

Figure 1-6-53

1-6-5 Transfer section

(1) Detaching and refitting the transfer roller assembly

Follow the procedure below to replace the transfer roller assembly.

Procedure

1. Open the bypass tray and paper conveying unit.
2. Remove the transfer roller assembly.
Caution: Remove the transfer roller assembly carefully to prevent the residual toner in the transfer roller assembly from spilling.
3. Replace the transfer roller assembly and refit all the removed parts.

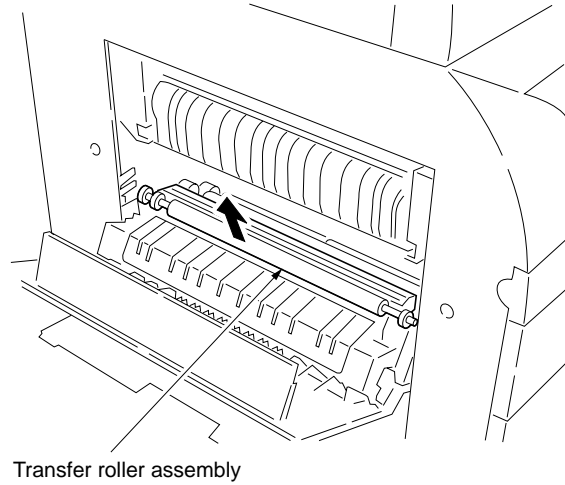

Figure 1-6-54

1-6-6 Fixing section

(1) Detaching and refitting the fixing unit

Follow the procedure below to check or replace the fixing unit.

Procedure

1. Open the paper conveying unit and remove the left cover.
2. Remove the two screws and detach the three connector and then remove the fixing unit.

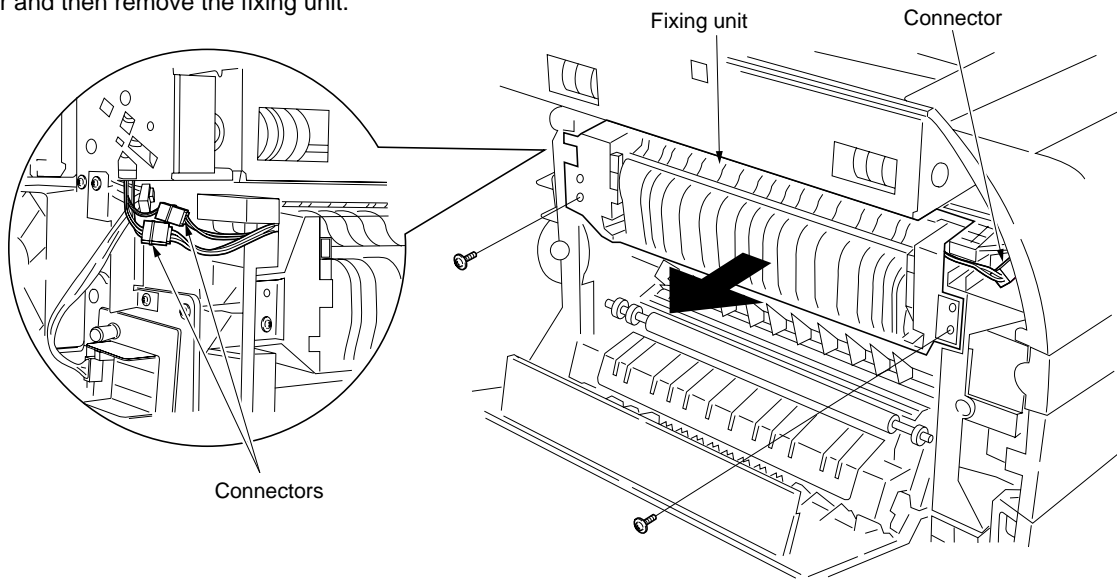

Figure 1-6-55

(2) Detaching and refitting the fixing unit thermistor

Follow the procedure below to replace the fixing unit thermistor.

Procedure

1. Remove the fixing unit.
2. Remove the screw and then remove the fixing unit thermistor.
3. Replace the fixing unit thermistor and refit all the removed parts.

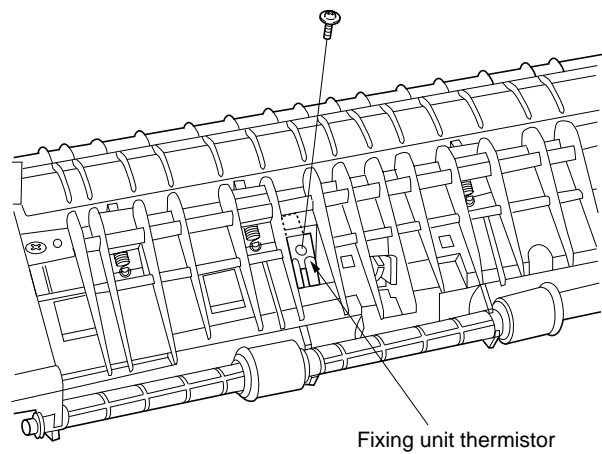

Figure 1-6-56

(3) Detaching and refitting the fixing heater

Follow the procedure below to replace the fixing heater.

Procedure

1. Remove the fixing unit (see page 1-6-34).
2. Remove the screw holding the fixing unit front cover and then the cover.

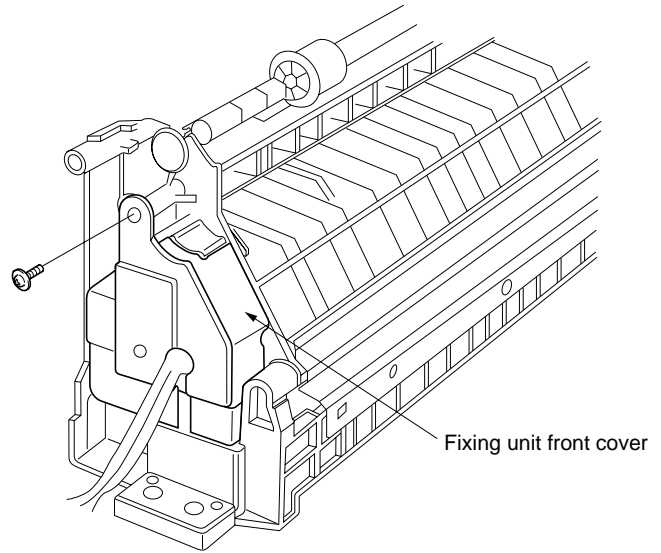
**Figure 1-6-57**

3. Remove the two screws and detach the fixing heater wire from the fixing thermostat.

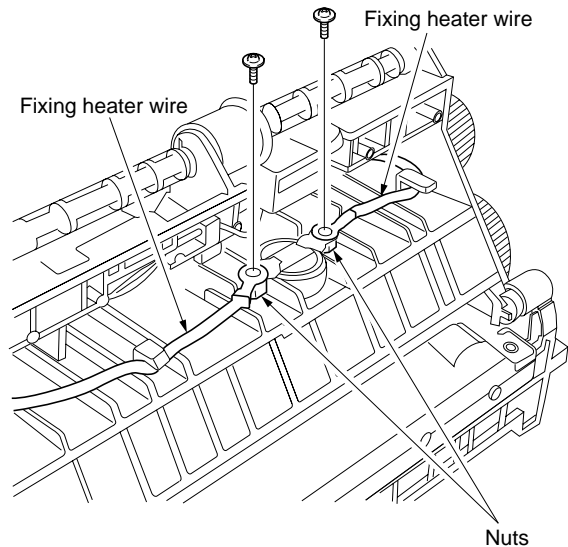
**Figure 1-6-58**

4. Remove the screw holding the fixing heater front retainer and then the retainer.

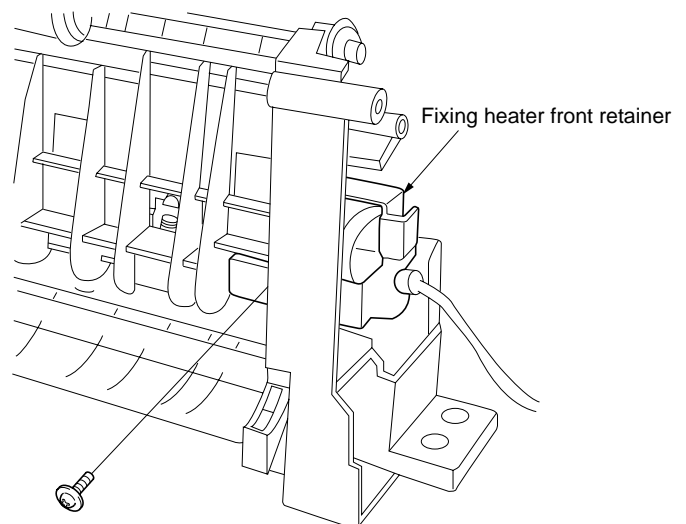
**Figure 1-6-59**

2BT

5. Pull out the fixing heater from the fixing unit.
6. Replace the fixing heater and refit all the removed parts.
 - Do not touch the glass surfaces of the fixing heater with bare hands.

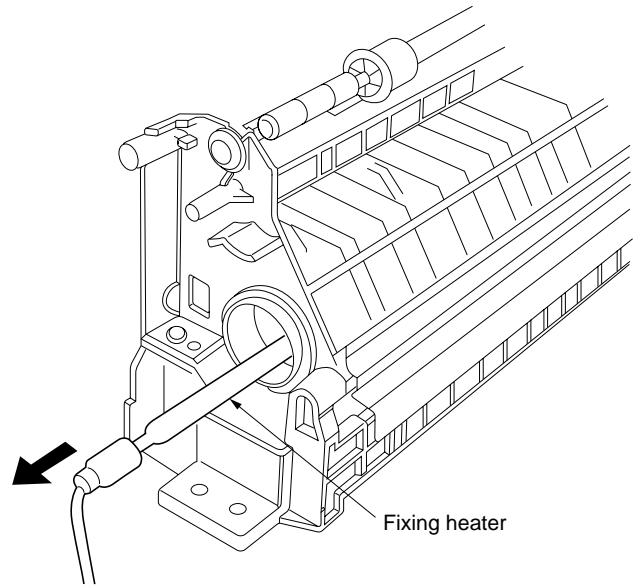

Figure 1-6-60

(4) Detaching and refitting the heat roller separation claws

Follow the procedure below to replace the heat roller separation claws.

Procedure

1. Remove the fixing unit (see page 1-6-34).
2. Remove the fixing heater (see page 1-6-35).
3. Remove the screw holding the fixing heater rear retainer and then the retainer.

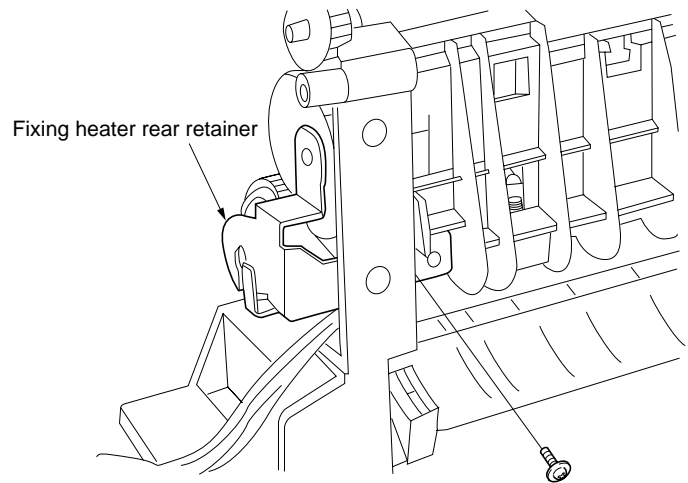

Figure 1-6-61

4. Remove the gear.
5. Remove the two screws and detach the upper fixing unit.

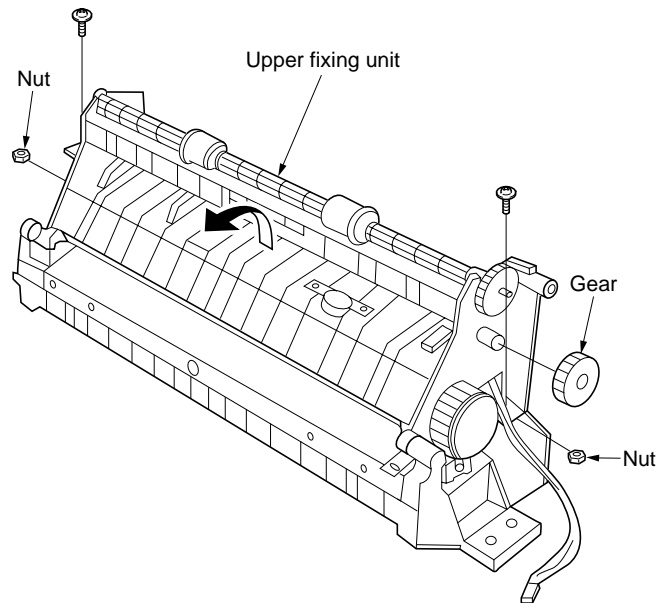

Figure 1-6-62

6. Remove the springs from the heat roller separation claws and then the claws.
7. Replace the heat roller separation claws and refit all the removed parts.

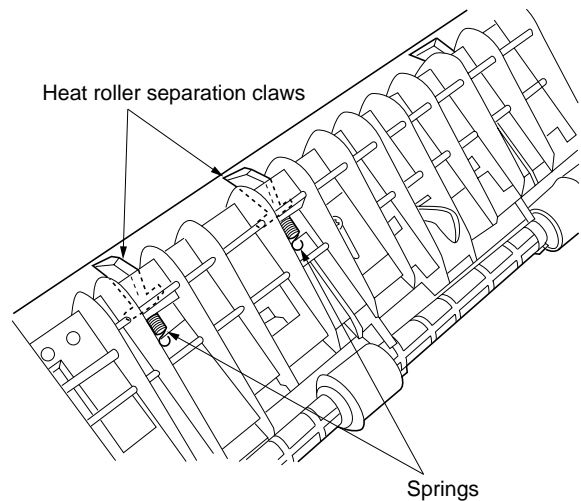

Figure 1-6-63

(5) Detaching and refitting the heat roller

Follow the procedure below to replace the heat roller.

Procedure

1. Remove the fixing unit (see page 1-6-34).
2. Remove the four heat roller separation claws (see page 1-6-37).
3. Remove the two C rings, gear and two bushings and then remove the heat roller.
4. Replace the heat roller and refit all the removed parts.

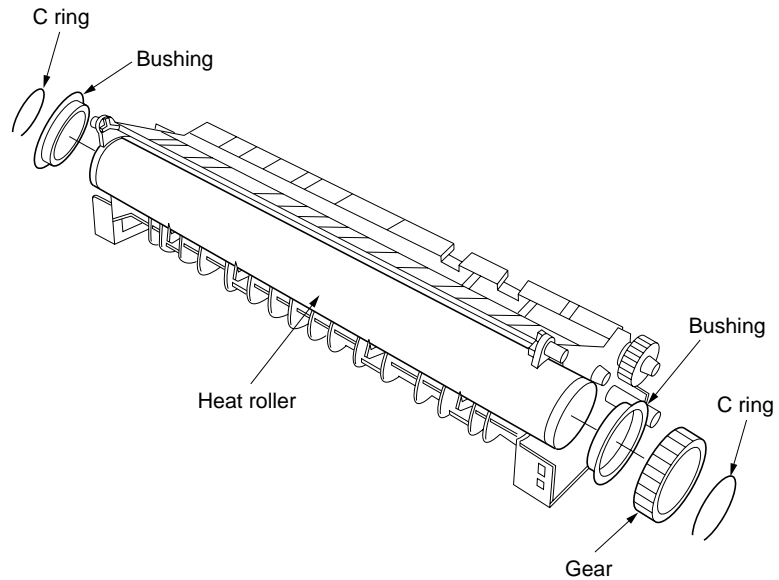

Figure 1-6-64

(6) Detaching and refitting the press roller

Follow the procedure below to replace the press roller.

Procedure

1. Remove the fixing unit (see page 1-6-34).
2. Remove the upper fixing unit (see page 1-6-37).
3. Remove the two screws holding the fixing guide plate and then the plate.

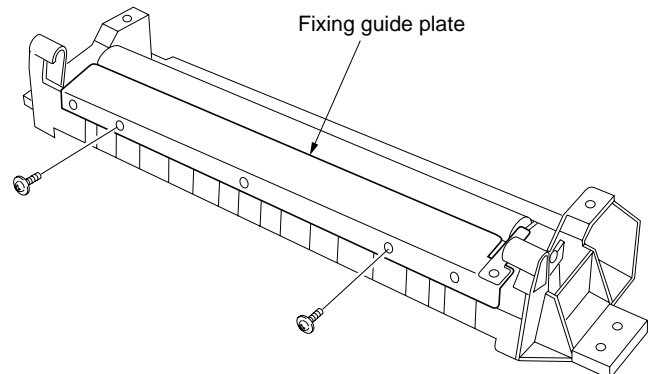

Figure 1-6-65

4. Move the fixing pressure release lever to the release position (in the direction of 1).
5. While holding the fixing pressure release levers outward, push the fixing pressure release levers further.

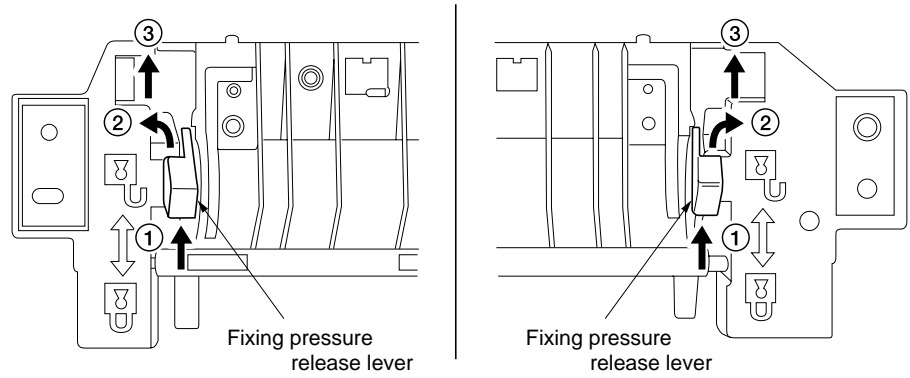

Figure 1-6-66

6. Remove each of two bearings and fixing pressure release levers and then remove the press roller.
7. Replace the press roller and refit all the removed parts.

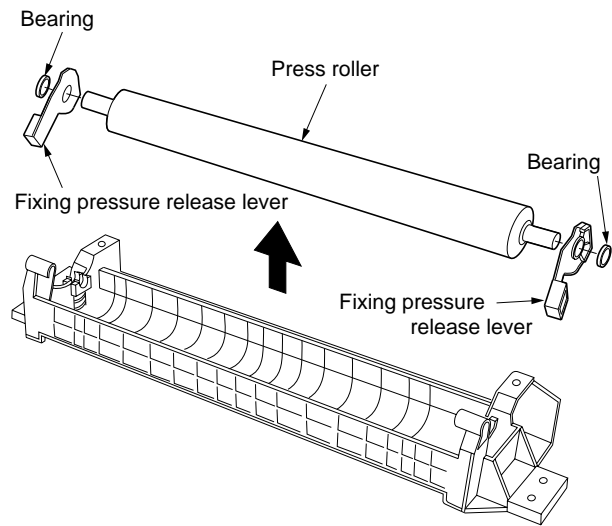

Figure 1-6-67

1-7-1 Replacing the main PCB

Main PCB replacement requires the following tools:
 Memory tool PCB (P/N 2AV68030)
 NVRAM (P/N NAS09010)

Procedure

- Before replacing the main PCB (backing up the machine data)
 1. Turn the main switch off and disconnect the power plug. Remove the right cover.
 2. After removing the printer cover, remove the 6 screws of machine shield cover. And then, remove the upper shield cover, lower shield cover and shield cover.

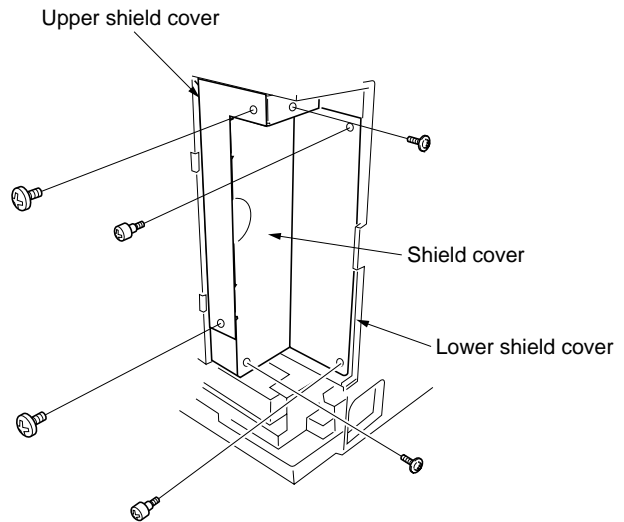

Figure 1-7-1

3. Fit the NVRAM to the memory tool PCB.
 - Caution:**
After fitting the NVRAM, do not remove it until the writing of the machine data completes.
4. Insert the memory tool PCB into the copier and connect its CN1 to CN19 on the main PCB.
 - Note:**
Insert the memory tool PCB along the upper and lower guides.

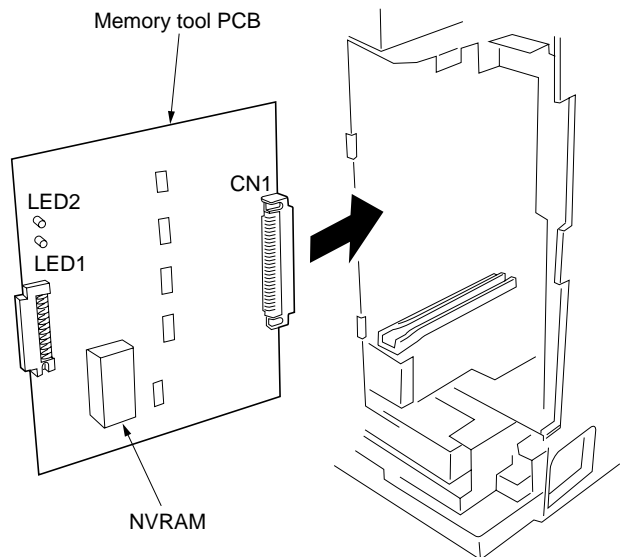

Figure 1-7-2

5. Insert the power plug and turn the main switch on. LED1 (green) on the memory tool PCB flashes (on for 1 s → off for 1 s) for approximately 10 seconds and the machine data on the SRAM of the main PCB will be backed up on the NVRAM.
6. When flashing LED1 (green) on the memory tool PCB remains lit, backing up of machine data is complete.
If an error occurs while the machine data is being backed up, LED1 (green) flashes and goes off in the patterns given below according to the nature of the error. Remove the memory tool PCB and perform the respective corrective measures and then back up the machine data again.

LED1	Description	Corrective measures
• - • - • - [•: On for 0.25 s] [-: Off for 0.25 s]	“WRITE” is selected in maintenance item U917.	Run maintenance item U917 and select “READ”.
	Since the NVRAM contains data from the previous operation, data cannot be written to it.	Replace the NVRAM on the memory tool PCB and back up the machine data again.
Off	The machine data was not transmitted from the SRAM on the main PCB to the NVRAM correctly.	Turn the main switch off and on and back up the machine data again. If the error persists, replace the NVRAM.

7. Turn the main switch off and disconnect the power plug.
8. Remove the memory tool PCB.
9. Replace the main PCB.

• After replacing the main PCB (writing the machine data)

10. Insert the power plug and turn the main switch on.
11. Upgrade the firmware on the main PCB. See pages 1-7-3.
12. Turn the main switch on.
13. Enter maintenance mode.
14. Run maintenance item U020.
15. Run maintenance item U252 and set the destination.
16. Run maintenance item U917 and select “WRITE”.
17. Exit maintenance mode.
18. Turn the main switch off and disconnect the power plug.
19. Insert the memory tool PCB into the copier and connect its CN1 to CN19 on the main PCB.

Note:

Insert the memory tool PCB along the upper and lower guides.

20. Insert the power plug and turn the main switch on. LED1 (green) on the memory tool PCB flashes (on for 0.5 s → off for 0.5 s → on for 0.5 s → off for 0.5 s → on for 1 s → off for 0.5 s) for approximately 10 seconds and the machine data on the NVRAM will be written to the SRAM on the main PCB.
21. When flashing LED1 (green) on the memory tool PCB remains lit, writing of the machine data is complete.
If an error occurs while the machine data is being written, LED1 (green) flashes and goes off in the patterns given below according to the nature of the error. Remove the memory tool PCB and perform the respective corrective measures and then write the machine data again.

LED1	Description	Corrective measures
• - • - • - [•: On for 0.25 s] [-: Off for 0.25 s]	“READ” is selected in maintenance item U917.	Run maintenance item U917 and select “WRITE”.
	An NVRAM with no backup data is used. (LED1 flashes for 10 s in the pattern on for 1 s and off for 1 s, and then flashes in the pattern described on the left.)	Replace the NVRAM on the memory tool PCB and then back up the machine data again.
• - • - • - • - [•: On for 0.25 s] [-: Off for 0.25 s] [-: Off for 1 s]	The machine data on the NVRAM may be damaged (checksum error).	Replace the NVRAM on the memory tool PCB and back up the machine data again.
Off	The machine data was not transmitted from the NVRAM to the SRAM on the main PCB correctly (SRAM problem).	Turn the main switch off and on and write the machine data again. If the error persists, replace the main PCB.

22. Remove the memory tool PCB and refit all the removed parts.

1-7-2 Upgrading the firmware on the main PCB

Firmware upgrading requires the following tools:

Flash tool assembly (P/N 35968010)

Memory tool PCB (P/N 2AV68030)

Master ROM: Main ROM IC (P/N 2BT68010)

Procedure

1. Turn the main switch off and disconnect the power plug.
2. Remove the two screws holding the upper shield cover and then the cover after removed the printer cover.

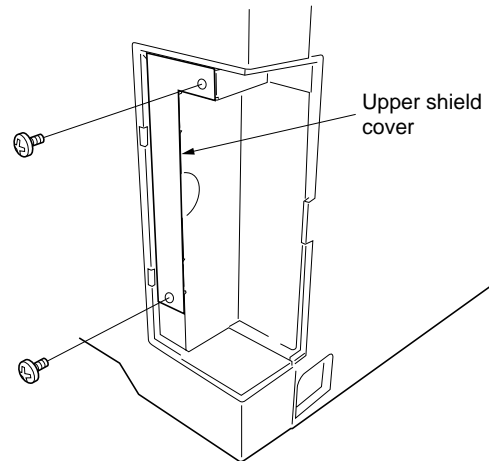

Figure 1-7-3

3. Fit the master ROM into the IC3 socket on the flash tool assembly.
4. Connect CN2 on the flash tool PCB to CN2 on the memory tool PCB.
5. Insert the memory tool PCB into the copier and connect its CN1 to CN19 on the main PCB.

Note:

Insert the memory tool PCB along the upper and lower guides.

6. Insert the power plug and turn the main switch on. LED2 (green) on the flash tool assembly flashes and upgrading of the master ROM starts.
7. When flashing LED2 (green) remains lit after approximately 30 to 40 seconds, upgrading of the master ROM is complete.
8. Turn the main switch on.
9. Remove the memory tool PCB.

Important:

"C021" may be indicated on the operation panel while upgrading the firmware. However, it does not interfere with the upgrading operation.

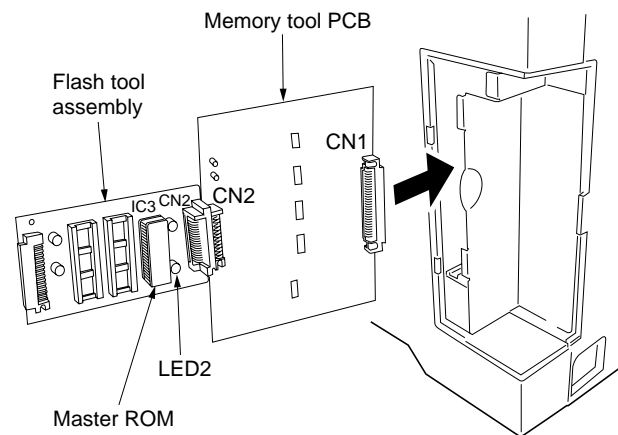

Figure 1-7-4

2BT

1-7-3 Adjustment-free variable resistors (VR)

The variable resistors listed below are set at the factory prior to shipping and cannot be adjusted in the field.

- High-voltage transformer PCB: VR101, VR102, VR201, VR301
- Inverter PCB: VR1

2-1-1 Paper feed section

The paper feed section consists of the primary feed and secondary feed subsections. Primary feed conveys paper from the drawer or bypass tray to the left and right registration rollers, at which point secondary feed takes place and the paper travels to the transfer section in sync with the printing timing.

The drawer can hold up to 250 sheets of paper. The bypass tray can hold up to 50 sheets of paper.

Paper is fed from the drawer by the rotation of the paper feed pulley. Paper is fed from the bypass tray by the rotation of the bypass paper feed pulley.

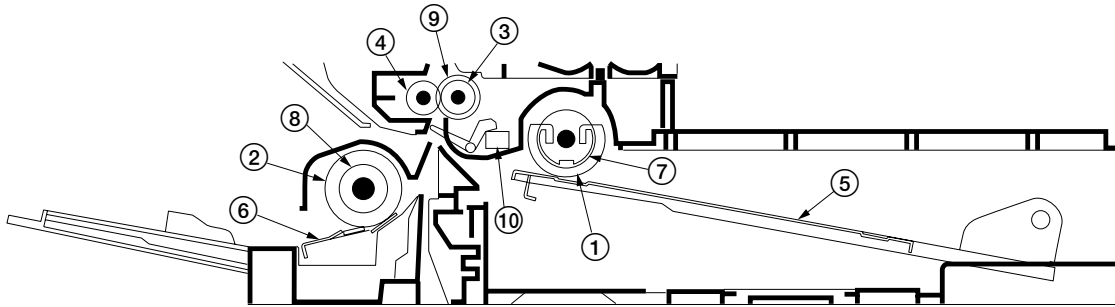

Figure 2-1-1 Paper feed section

- | | |
|-----------------------------|--------------------------------------|
| ① Paper feed pulley | ⑥ Bypass lift |
| ② Bypass paper feed pulley | ⑦ Paper feed clutch (PFCL) |
| ③ Right registration roller | ⑧ Bypass paper feed clutch (BYPPFCL) |
| ④ Left registration roller | ⑨ Registration clutch (RCL) |
| ⑤ Drawer bottom plate | ⑩ Registration switch (RSW) |

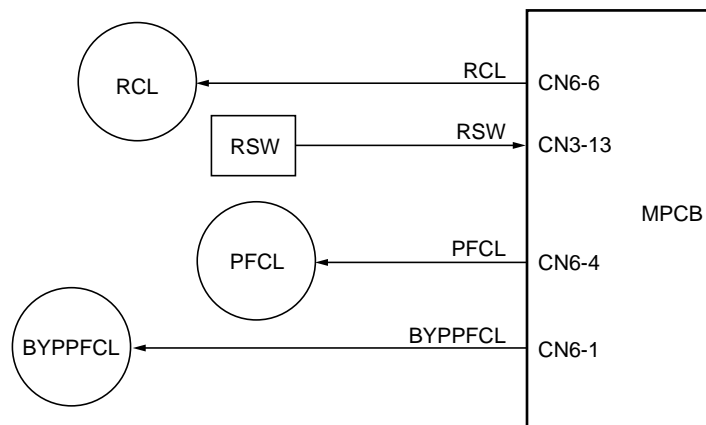
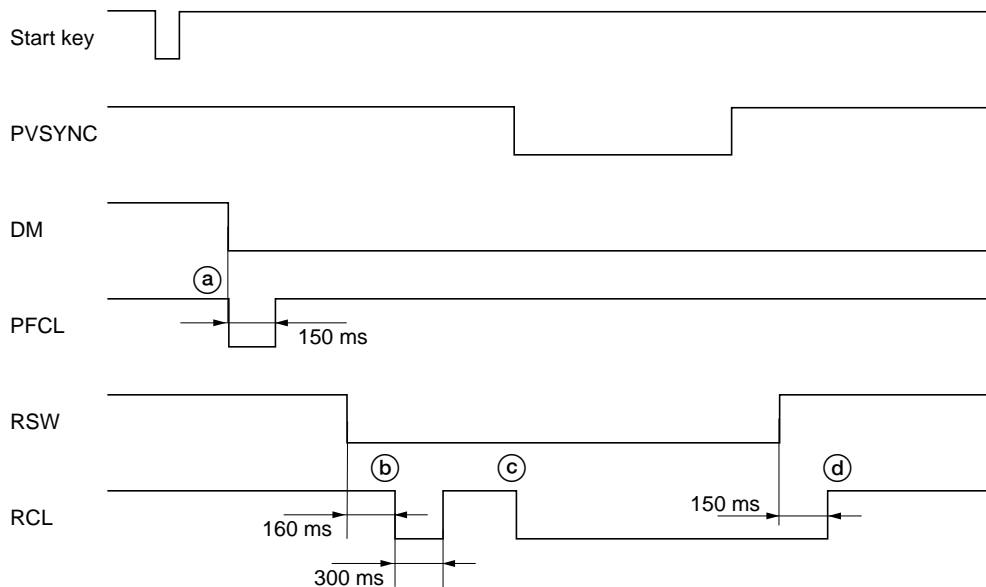
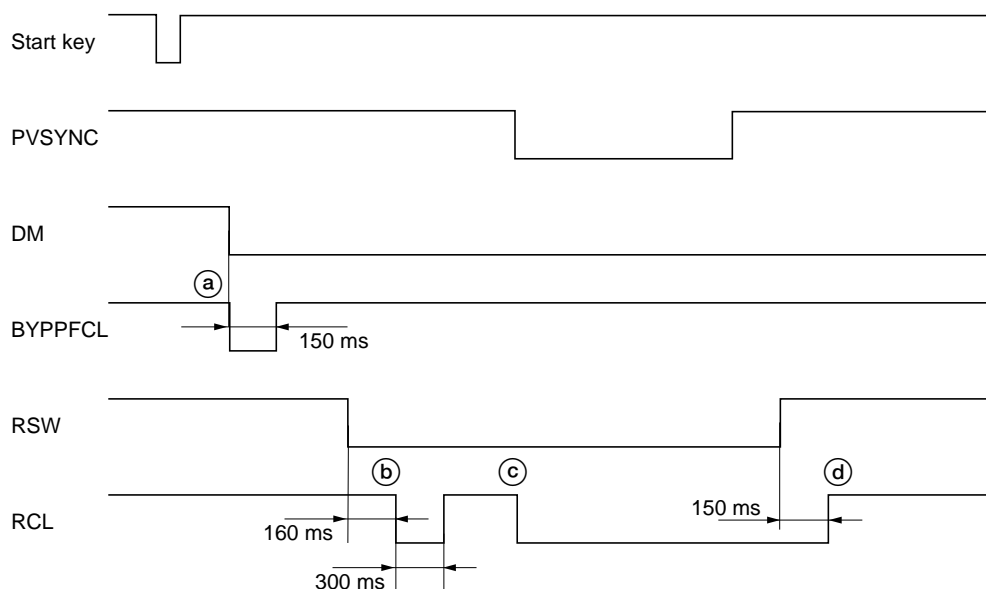

Figure 2-1-2 Paper feed section block diagram



Timing chart 2-1-1 Paper feed from the drawer

- Ⓐ: When the drive motor (DM) turns on, the paper feed clutch (PFCL) turns on for 150 ms to start primary paper feed.
- Ⓑ: 160 ms after the leading edge of the paper turns the registration switch (RSW) on, the registration clutch (RCL) turns on for 300 ms.
- Ⓒ: When the PVSYNC signal from the optical section turns on, the registration clutch (RCL) turns on to start secondary paper feed.
- Ⓓ: 150 ms after the trailing edge of the paper turns the registration switch (RSW) off, the registration clutch (RCL) turns off.



Timing chart 2-1-2 Paper feed from the bypass tray

- Ⓐ: When the drive motor (DM) turns on, the bypass paper feed clutch (BYPPFCL) turns on for 150 ms to start primary paper feed.
- Ⓑ: 160 ms after the leading edge of the paper turns the registration switch (RSW) on, the registration clutch (RCL) turns on for 300 ms.
- Ⓒ: When the PVSYNC signal from the optical section turns on, the registration clutch (RCL) turns on to start secondary paper feed.
- Ⓓ: 150 ms after the trailing edge of the paper turns the registration switch (RSW) off, the registration clutch (RCL) turns off.

2-1-2 Main charging section

The main charging section consists of the drum and main charger unit. The drum is electrically charged plus by means of a grid to form a latent image on the surface. The shield grid ensures that the charge is applied uniformly.

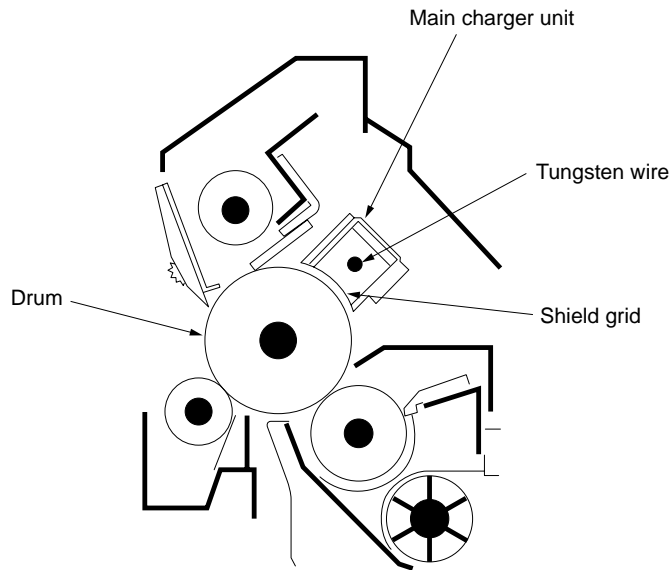

Figure 2-1-3 Main charging section

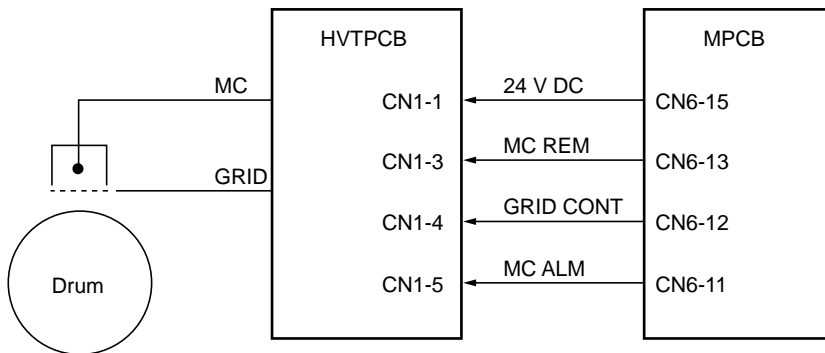
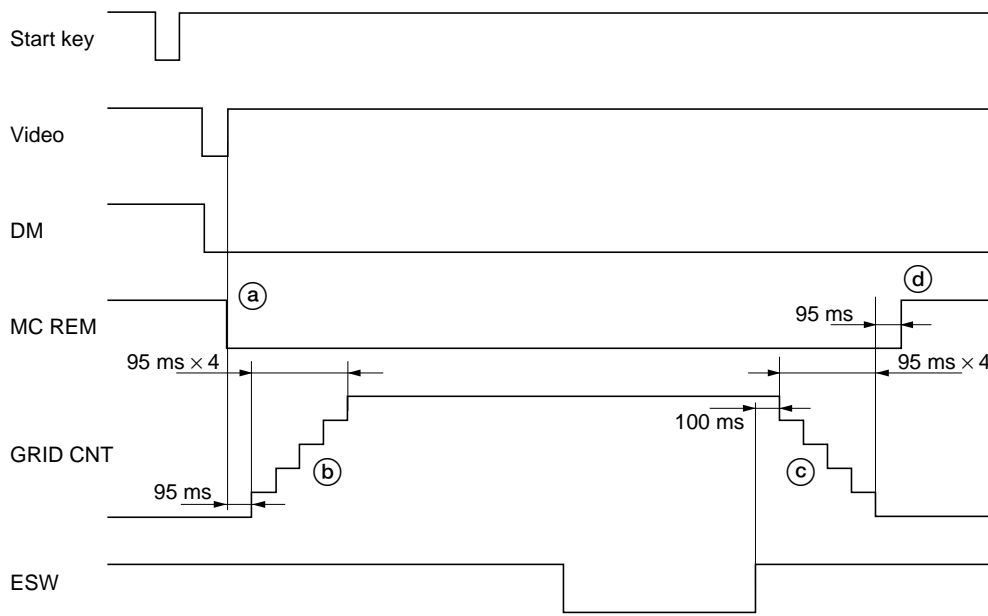

Figure 2-1-4 Main charging section block diagram



Timing chart 2-1-3 Main charging

- (a): When the Video signal is received from the optical section, main charging (MC REM) starts.
- (b): 95 ms after main charging (MC REM) starts, the grid control voltage (GRID CNT) increases in stages.
- (c): 100 ms after the trailing edge of the paper turns the eject switch (ESW) off, the grid control voltage (GRID CNT) decreases in stages.
- (d): 95 ms after the grid control voltage (GRID CNT) turns off, main charging (MC REM) completes.

2-1-3 Optical section

The optical section consists of the scanner, mirror frames and the image scanning unit for scanning and the laser scanner unit for printing.

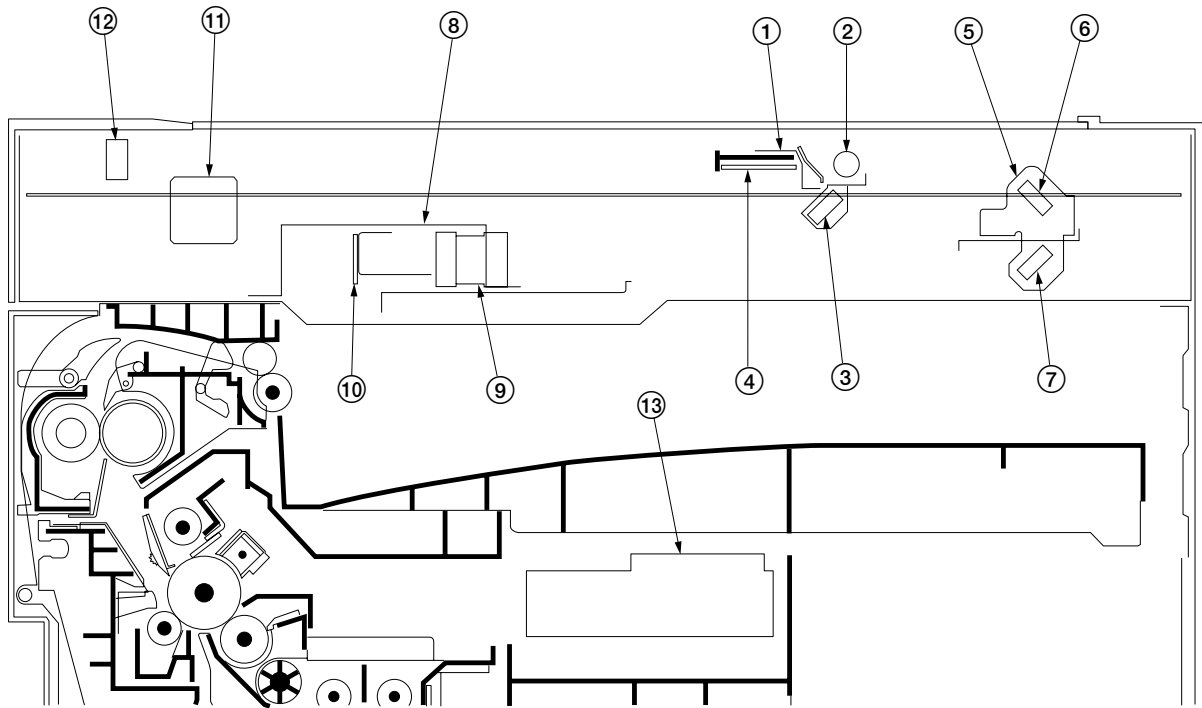

Figure 2-1-5 Optical section

- ① Mirror 1 frame
- ② Exposure lamp (EL)
- ③ Mirror 1
- ④ Inverter PCB (INPCB)
- ⑤ Mirror 2 frame
- ⑥ Mirror 2
- ⑦ Mirror 3
- ⑧ Image scanning unit (ISU)
- ⑨ Lens
- ⑩ CCD PCB (CCDPCB)
- ⑪ Scanner motor (SM)
- ⑫ Scanner home position switch (SHPSW)
- ⑬ Laser scanner unit (LSU)

(1) Original scanning

The original image is illuminated by the exposure lamp (EL) and scanned by the CCD PCB (CCDPCCB) in the image scanning unit via the three mirrors, the reflected light being converted to an electrical signal.

The scanner and mirror frames travel to scan on the optical rails on the front and rear of the machine to scan from side to side. The speed of the mirror frames is half the speed of the scanner.

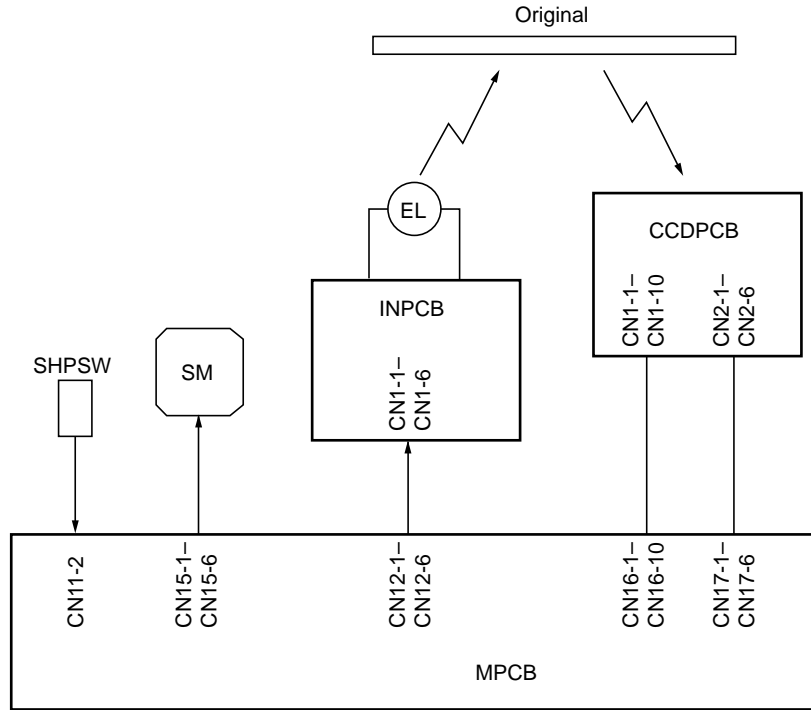
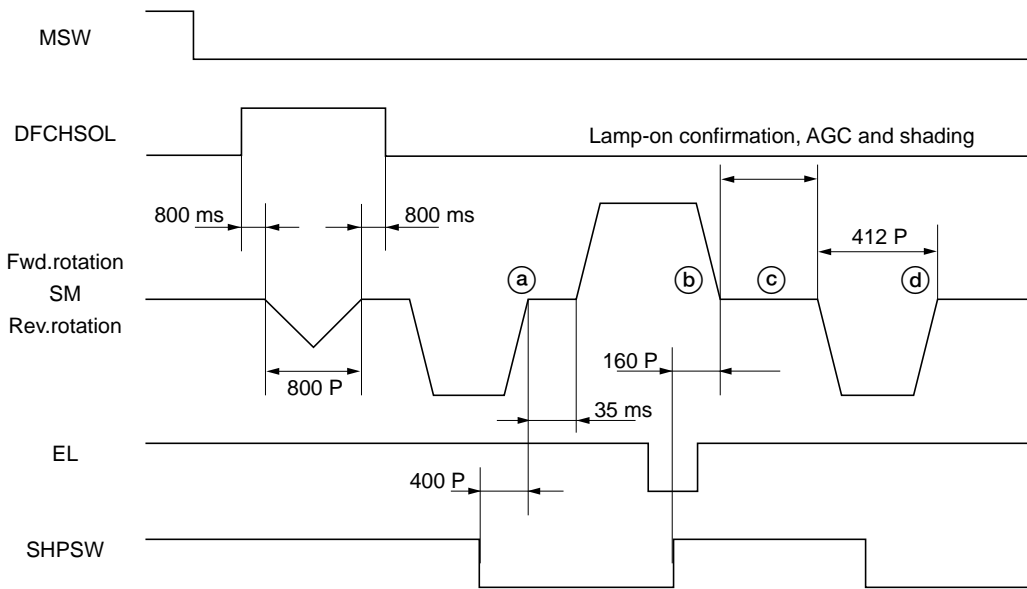

Figure 2-1-6 Optional section block diagram



• When the scanner home position switch (SHPSW) is off at power-on

Timing chart 2-1-4 Scanner operation (1)

- Ⓐ: After the main switch (MSW) is turned on, the scanner motor (SM) rotates in reverse, which turns off 400 scanner motor pulses after the scanner home position switch (SHPSW) turns on.
- Ⓑ: 35 ms after the scanner motor (SM) turns off, it rotates forward, which turns off 160 scanner motor pulses after the scanner home position switch (SHPSW) turns off.
- Ⓒ: Lighting of the exposure lamp is confirmed, the AGC is performed and shading is corrected.
- Ⓓ: The scanner motor (SM) rotates in reverse for 412 scanner motor pulses, at the end of which the scanner stops at the scanning start position for the original on the contact glass.

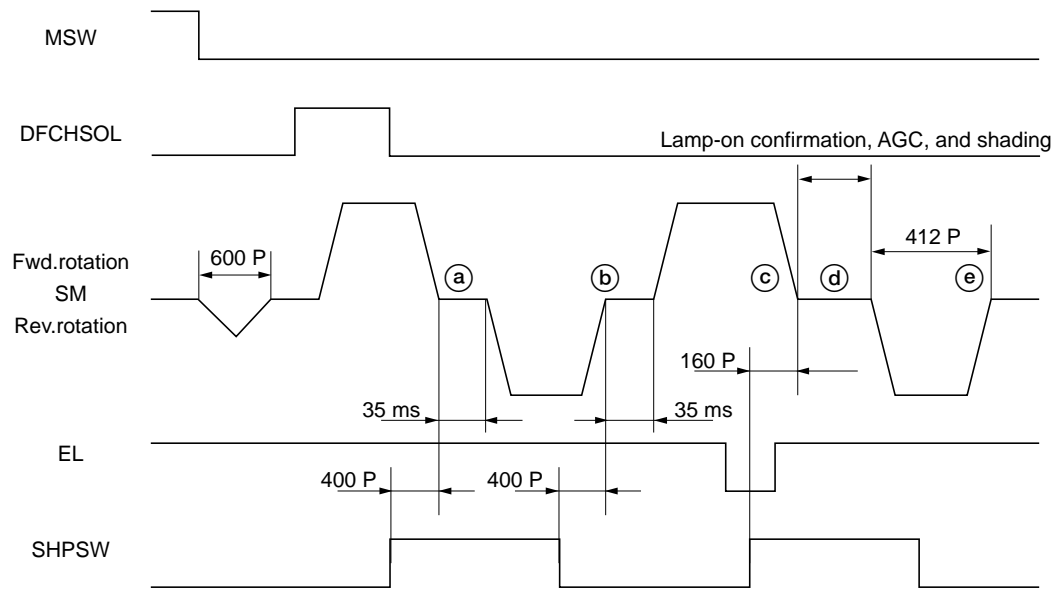

- When the scanner home position switch (SHPSW) is on at power-on

Timing chart 2-1-5 Scanner operation (2)

- Ⓐ: When the main switch (MSW) turns on, the scanner motor (SM) rotates forward, which turns off 400 scanner motor pulses after the scanner home position switch (SHPSW) turns off.
- Ⓑ: 35 ms after the scanner motor (SM) turns off, it rotates in reverse, which turns off 400 scanner motor pulses after the scanner home position switch (SHPSW) turns on.
- Ⓒ: 35 ms after the scanner motor (SM) turns off, it rotates forward, which turns off 160 scanner motor pulses after the scanner home position switch (SHPSW) turns off.
- Ⓓ: Lighting of the exposure lamp is confirmed, the AGC is performed, and shading is corrected.
- Ⓔ: The scanner motor (SM) rotates in reverse for 412 scanner motor pulses, at the end of which the scanner stops at the scanning start position for the original on the contact glass.

(2) Image printing

The image data scanned by the CCD PCB (CCDPCB) is processed on the main PCB (MPCB) and transmitted as image printing data to the laser scanner unit (LSU). By repeatedly turning the laser on and off, the laser scanner unit forms a latent image on the drum surface.

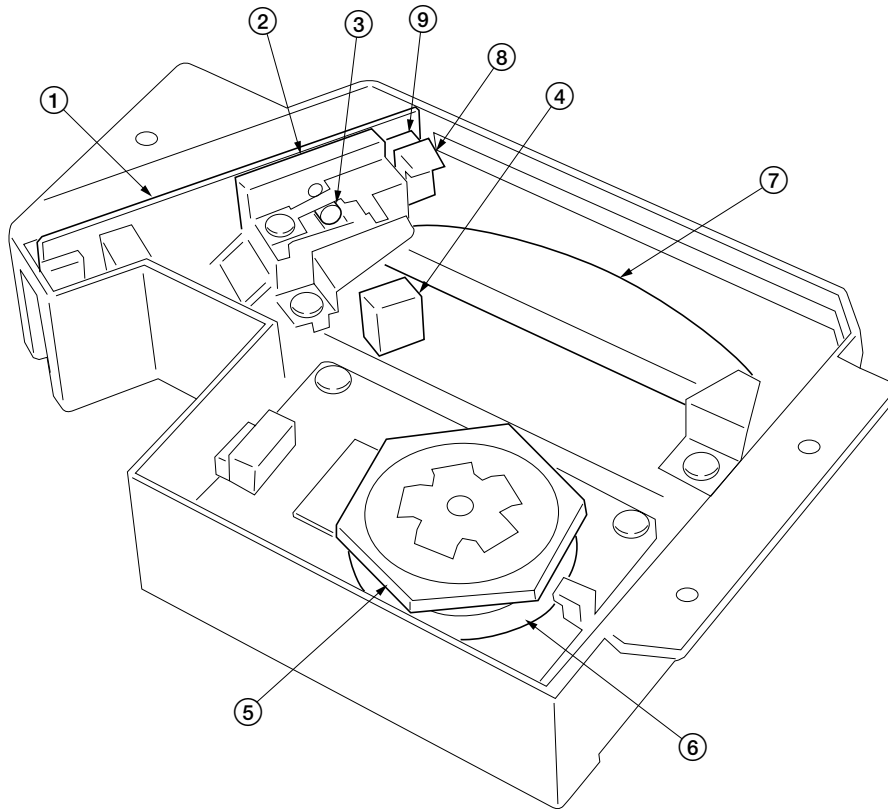

Figure 2-1-7 Laser scanner unit (1)

- ① Laser diode PCB (LDPCB)
- ② Laser diode
- ③ Collimator lens
- ④ Cylindrical lens
- ⑤ Polygon mirror
- ⑥ Polygon motor (PM)
- ⑦ fθ lens
- ⑧ BD sensor mirror
- ⑨ BD sensor

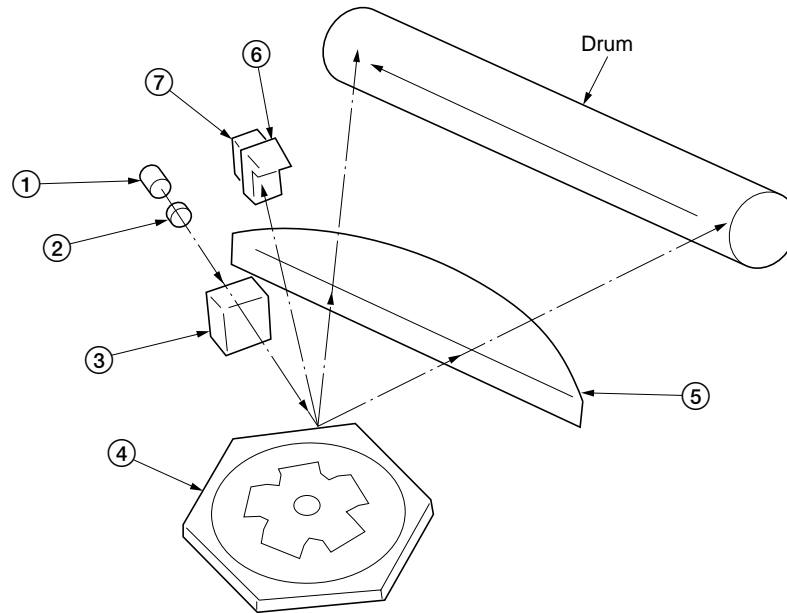

Figure 2-1-8 Laser scanner unit (2)

- ① Laser diode: Generates the laser beam which forms a latent image on the drum.
- ② Collimator lens: Collimates the diffused laser beam emitted from the laser diode to convert it into a cylindrical beam.
- ③ Cylindrical lens: Shapes the collimated laser beam to suit the printing resolution.
- ④ Polygon mirror: Six-facet mirror that rotates at approximately 25984 rpm with each face reflecting the laser beam toward the drum for one main-direction scan.
- ⑤ Fθ lens: Corrects for non-linearity of the laser beam scanning speed on the drum surface, keeps the beam diameter constant and corrects for the vertical alignment of the polygon mirror to ensure that the focal plane of the laser beam is on the drum surface.
- ⑥ BD sensor mirror: Reflects the laser beam to the BD sensor to generate the main-direction (horizontal) sync signal.
- ⑦ BD sensor: Detects the beam reflected by the BD sensor mirror, outputting a signal to the main PCB (MPCB) to provide timing for the main-direction sync signal.

The dimensions of the laser beam are as shown in Figure 2-1-9.

Scanning in the main direction is provided by the rotating polygon mirror, while scanning in the auxiliary direction is provided by the rotating drum, forming a static latent image on the drum.

The static latent image of the letter “A”, for example, is formed on the drum surface as shown in Figure 2-1-10. Electrical charge is dissipated on the area of the drum surface irradiated by the laser.

The focal point of the laser beam is moved line by line, and adjacent lines slightly overlap each other.

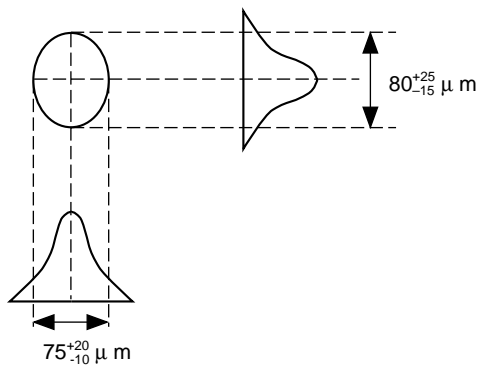

Figure 2-1-9

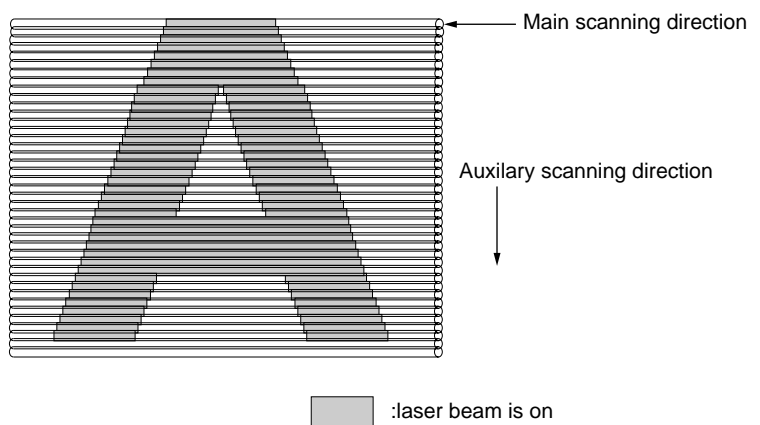

Figure 2-1-10

2-1-4 Developing section

The developing section consists of the developing unit and the toner container. The developing unit consists of the developing roller where a magnetic brush is formed, the doctor blade and the developing spirals that agitate the developer.

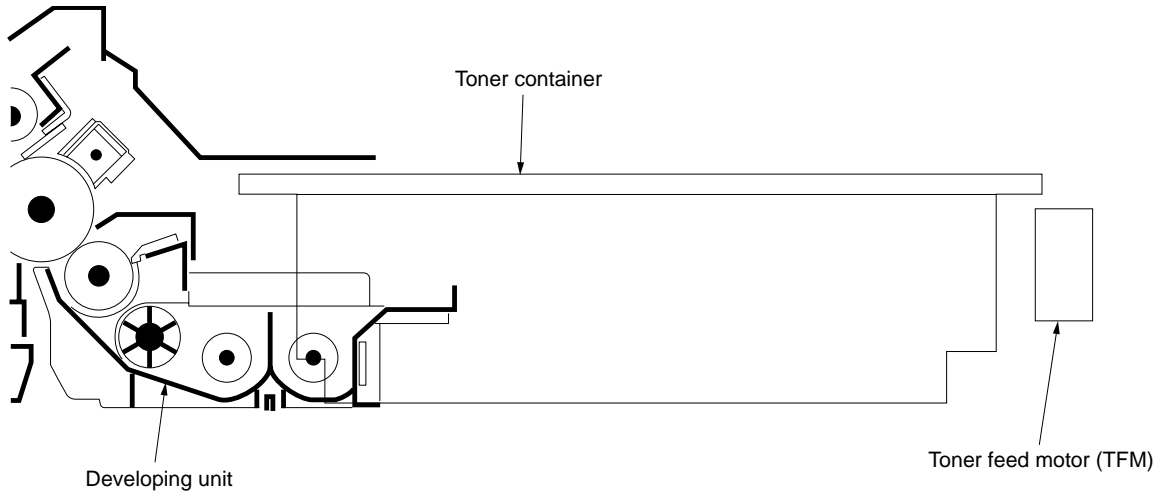

Figure 2-1-11 Developing section

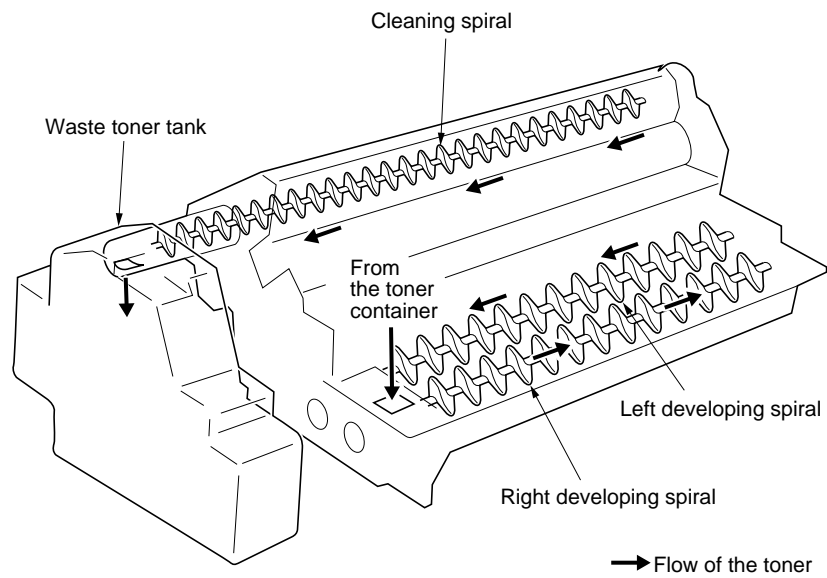
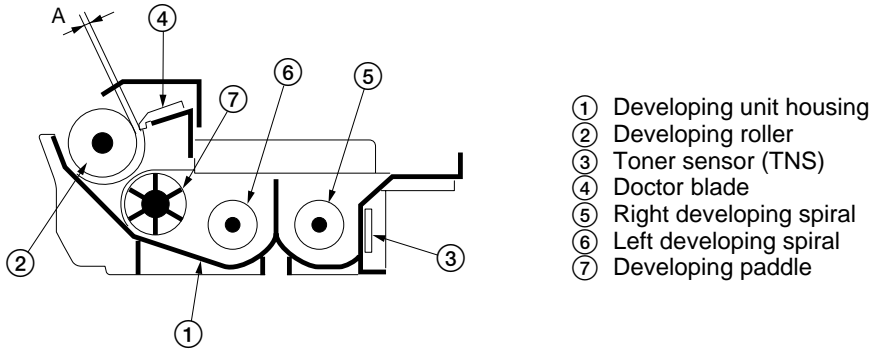

Figure 2-1-12 Flow of the toner

(1) Formation of magnetic brush

The developing roller consists of a magnet roller with five poles and a sleeve roller. Rotation of the sleeve roller around the magnet roller entrains developer, which in turn forms a magnetic brush at pole N1 on the magnet roller. The height of the magnetic brush is regulated by the doctor blade; the developing result is affected by the position of the poles on the magnet roller and the position of the doctor blade.

A developing bias voltage generated by the high-voltage transformer PCB (HVTPCB) is applied to the developing roller to provide image contrast.



A: Distance between the doctor blade and developing roller: $0.6^{+0.1}_{-0.05}$ mm

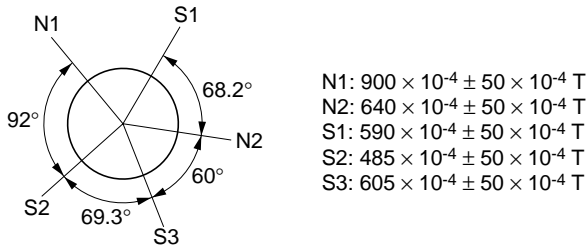

Figure 2-1-13 Forming a magnetic brush

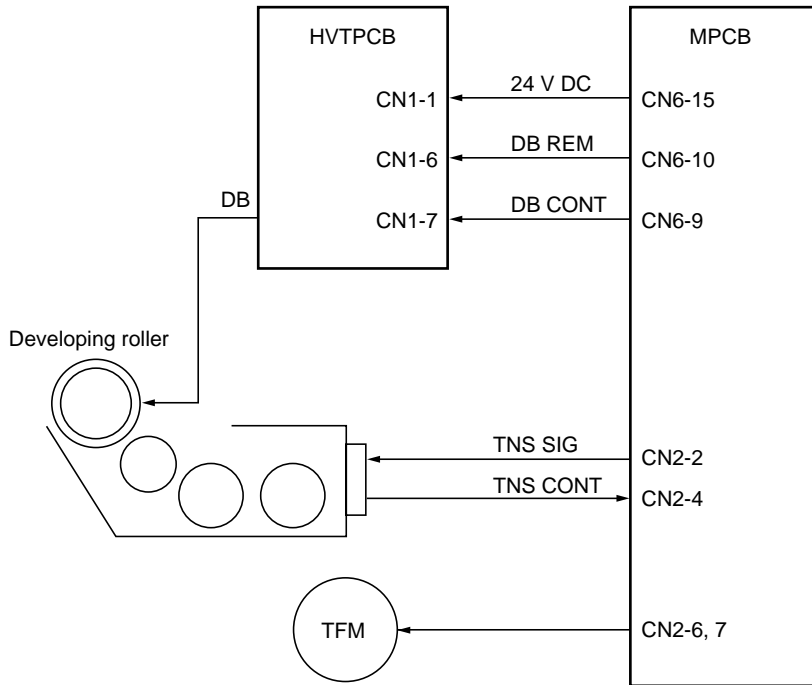

Figure 2-1-14 Developing section block diagram

(2) Toner density detection by the toner sensor

The toner sensor (TNS) detects the toner density. As the developer passes by the sensor section of the toner sensor, the toner sensor detects the ratio of toner to carrier in the developer and converts it into a voltage. When more toner is used, the ratio of toner to carrier decreases and the toner sensor output voltage increases. When the ratio drops below the specified value, the increase in toner sensor output voltage triggers toner replenishing. When toner is added and the ratio of toner to carrier returns to normal, the toner sensor output voltage drops to the point where toner replenishing stops.

(3) Toner density control

Figure 2-1-15 Toner density control

- Ⓐ: If the toner sensor output voltage exceeds the toner feed start level 15 s after the drive motor (DM) has turned on (end of toner empty detection inhibit time), the toner feed motor (TFM) turns on to replenish toner.
- Ⓑ: As toner is replenished, the toner sensor output voltage falls until it drops below the toner feed stop level and replenishing stops.
- Ⓒ: When the toner sensor output voltage exceeds the toner empty detection level after toner replenishing is carried out, the toner being replenished message appears disabling copying and forced toner feed starts. If the toner sensor output voltage fails to fall to the toner feed stop level within 180 s of the start of forced toner feed, the toner request message appears.
- Ⓓ: When toner is replenished, the toner sensor output voltage falls until it drops below the toner feed stop level and replenishing stops. After 60 s aging (15 s while copying) the toner being replenished message disappears and copying is enabled.
- Ⓔ: After replacing the toner container and the waste toner tank, the toner feed motor (TFM) turns on to replenish toner.
- Ⓕ: When toner is replenished, the toner sensor output voltage falls until it drops to the toner feed stop level. The toner being replenished message disappears and replenishing stops.

(4) Correcting the toner sensor control voltage

The toner sensor control voltage is corrected based on the absolute humidity and the total drive motor time so that the toner density is kept constant regardless of the changes in humidity and the total drive motor time.

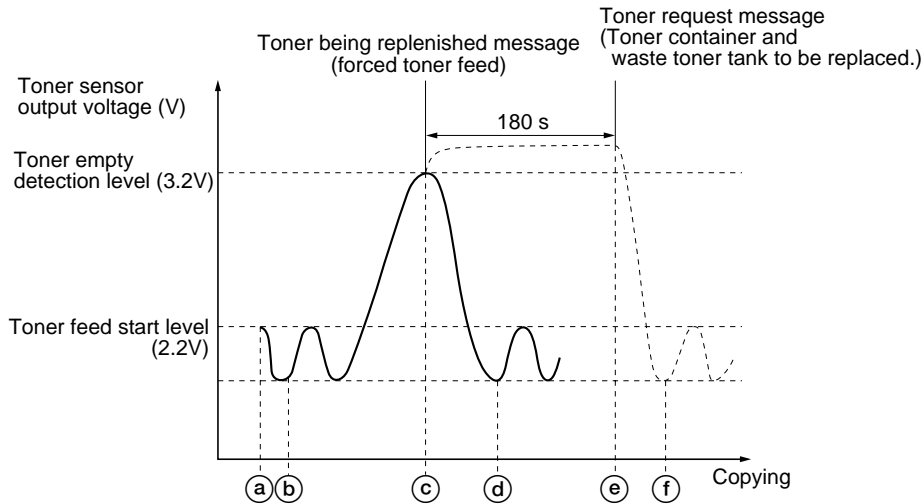
Toner sensor control voltage after correction = A + B + C

A: Toner sensor control voltage before correction (value set by maintenance item U131)

B: Correction data based on the absolute humidity

C: Correction data based on the total drive motor time

• **Correction based on the absolute humidity**

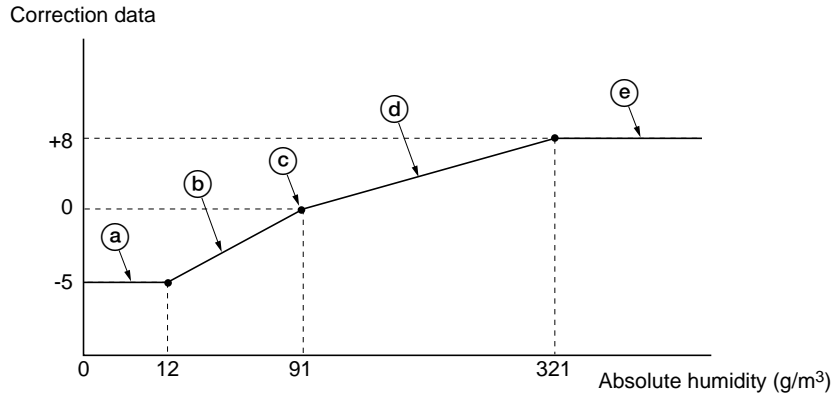

Figure 2-1-16 Correction based on the absolute humidity

- (a): When the absolute humidity is between 0 and 12 g/m³, the correction data becomes a constant value of -5, which decreases the toner sensor control voltage.
- (b): When the absolute humidity is between 12 and 91 g/m³, the correction data is increased according to the rise in absolute humidity.
- (c): When the absolute humidity is 91 g/m³, the correction data becomes 0.
- (d): When the absolute humidity is between 91 and 321 g/m³, the correction data is increased according to the rise in absolute humidity, which increases the toner sensor control voltage.
- (e): When the absolute humidity exceeds 321 g/m³, the correction data becomes a constant value of +8, which increases the toner sensor control voltage.

Computing the absolute humidity

The humidity sensor (HUMSENS) converts the relative humidity detected by the humidity sensing element into a voltage and sends it to the main PCB (MPCB). The main PCB (MPCB) computes the absolute humidity based on this HUMSENS signal and the temperature (ETTH signal) detected by the external temperature thermistor (ETTH).

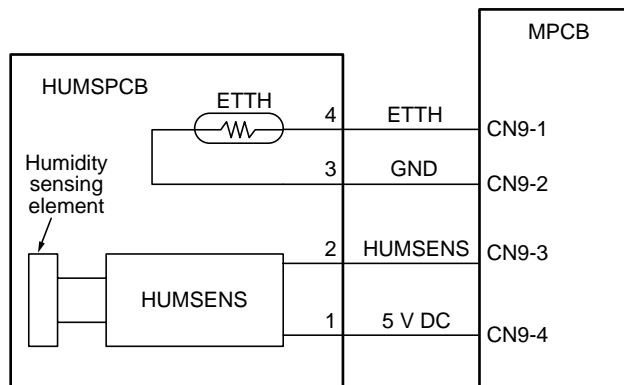

Figure 2-1-17 Absolute humidity computation block diagram

• **Correction based on the total drive motor time**

The toner sensor control voltage is also corrected based on the total time the drive motor (DM) has been on from execution of maintenance item U130, so that the toner sensor output voltage is regulated properly.

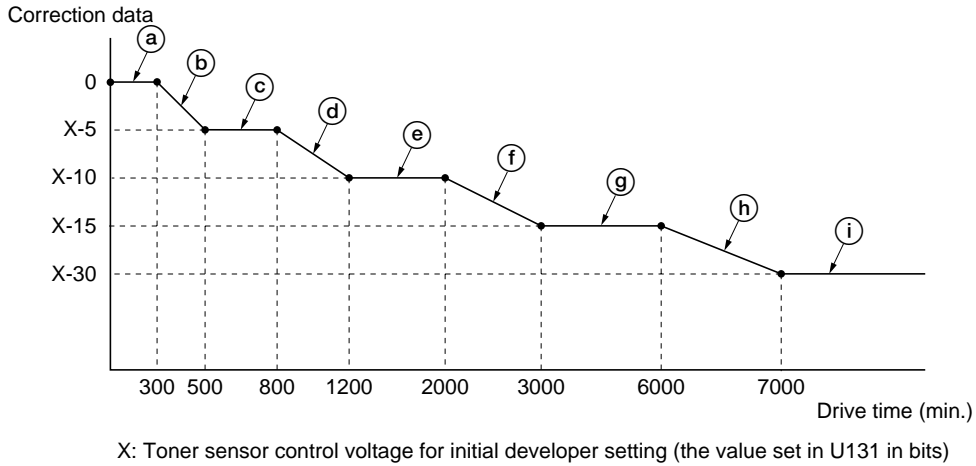

Figure 2-1-18 Correction based on the total drive motor time

- Ⓐ: When maintenance item U130 is run for initial developer setting, the total drive motor time is cleared and the toner sensor control voltage correction data becomes 0.
- Ⓑ: When the total drive motor time is between 300 and 500 min., the correction data is decreased according to the increase in the total drive motor time.
- Ⓒ: When the total drive motor time is between 500 and 800 min., the toner sensor control voltage is corrected with a constant value of -5.
- Ⓓ: When the total drive motor time is between 800 and 1200 min., the correction data is decreased according to the increase in the total drive motor time.
- Ⓔ: When the total drive motor time is between 1200 and 2000 min., the toner sensor control voltage is corrected with a constant value of -10.
- Ⓕ: When the total drive motor time is between 2000 and 3000 min., the correction data is decreased according to the increase in the total drive motor time.
- Ⓖ: When the total drive motor time is between 3000 and 6000 min., the toner sensor control voltage is corrected with a constant value of -15.
- Ⓗ: When the total drive motor time is between 6000 and 7000 min., the correction data is decreased according to the increase in the total drive motor time.
- Ⓘ: When the total drive motor time exceeds 7000 min., the toner sensor control voltage is corrected with a constant value of -30.

(5) Correcting toner sensor output voltage

The toner sensor output voltage is corrected according to the absolute humidity at power-on (the main switch turning on), fixing temperature and accumulated drive time.

Toner sensor output voltage after correction = Toner sensor output voltage before correction - Correction data at power-on

Correction data at power-on = A - B

If A - B ≤ 0, the correction data at power-on is 0

A: Correction data based on the absolute humidity and fixing temperature

B: Accumulated drive time from the main switch turning on (total drive motor on-time)

If the fixing temperature at the main switch turning on is 50°C/122°F or below, correction data A is determined as follows:

Condition	Correction data A
The absolute humidity at the last main switch turning off was 50 g/m ³ or below and the absolute humidity at the main switch turning on was 50 g/m ³ or below.	+15
Cases other than above.	+50

If the fixing temperature at the main switch turning on is 50°C/122°F or above, the value of correction data A applied when the main switch was last turned off is used.

2-1-5 Transfer and separation section

The transfer and separation section consists mainly of the transfer roller and drum separation claws. A high voltage generated by the high-voltage transformer PCB (HVTPCB) is applied to the transfer roller for transfer charging minus. Toner adhered to the transfer roller is removed by the transfer cleaner.

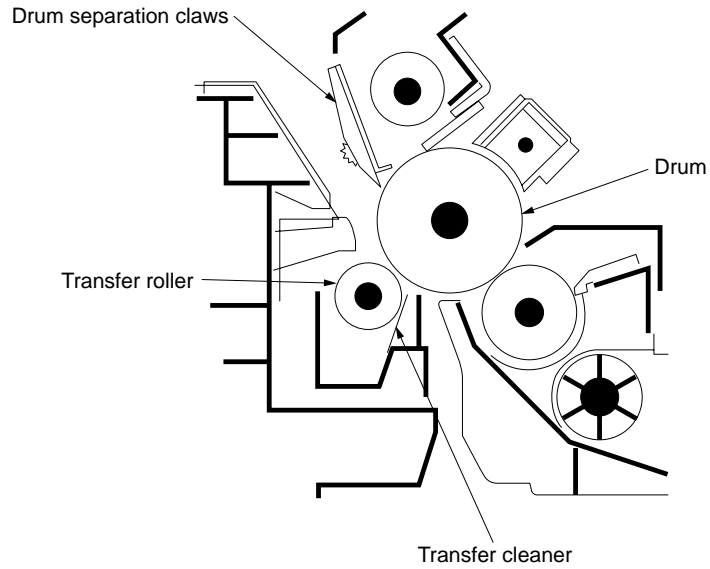

Figure 2-1-19 Transfer and separation section

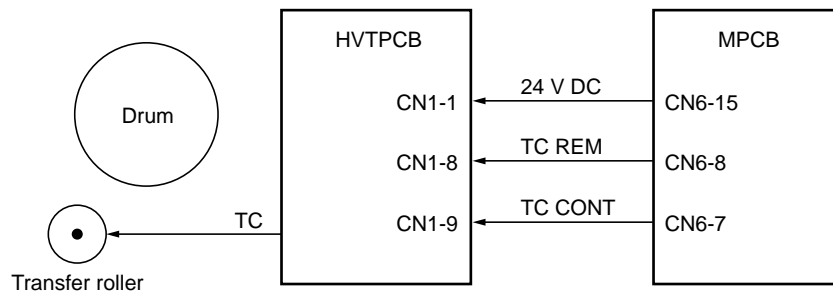
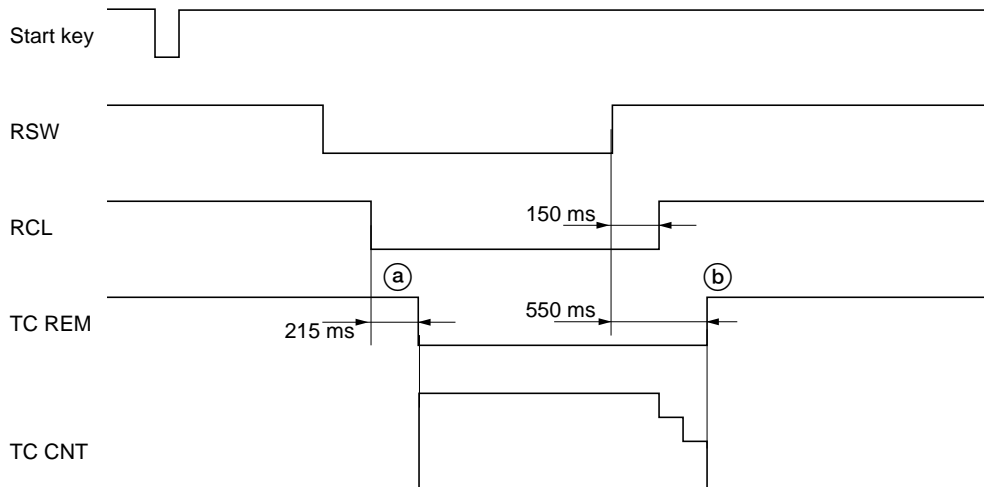

Figure 2-1-20 Transfer and separation section block diagram



Timing chart 2-1-6 Operation of transfer

- Ⓐ: 215 ms after the registration clutch (RCL) turns on to start secondary paper feed, transfer charging (TC REM) starts.
- Ⓑ: 550 ms after the trailing edge of the paper turns the registration switch (RSW) off, transfer charging (TC REM) ends.

2-1-6 Cleaning section

The cleaning section consists of the cleaning blade that removes residual toner from the drum surface after the transfer process, and the cleaning spiral that carries the residual toner back to the waste toner tank. The cleaning blade is equipped with a thrust mechanism to protect the blade and drum from scratches.

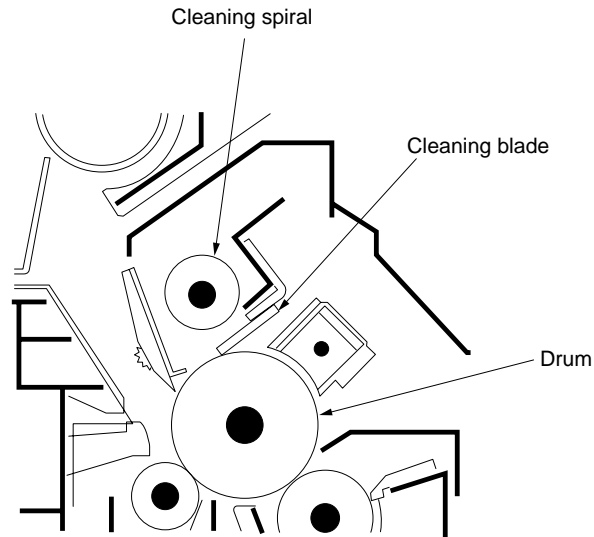

Figure 2-1-21 Cleaning section

2-1-7 Charge erasing section

The cleaning lamp (CL) consists of LEDs which remove residual charge from the drum surface.

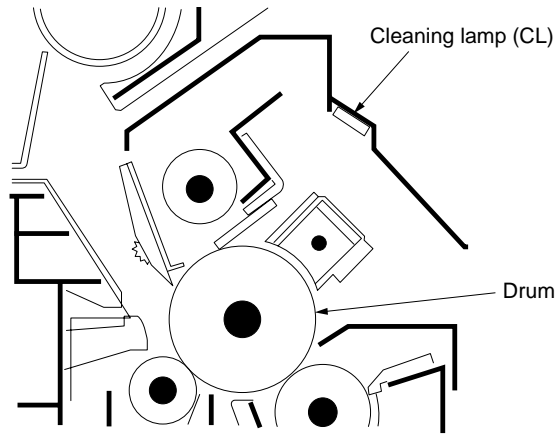

Figure 2-1-22 Charge erasing section

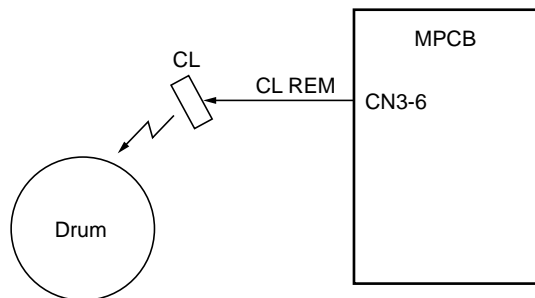

Figure 2-1-23 Charge erasing section block diagram

2-1-8 Fixing section

The fixing section consists of the parts shown in Figure 2-1-25. When paper reaches the fixing section after the transfer process, it passes between the press roller and heat roller, which is heated by the fixing heater (FH). Pressure is applied by the fixing unit pressure springs so that the toner on the paper is melted, fused and fixed onto the paper.

When the fixing process is completed, the paper is separated from the heat roller by heat roller separation claws and is ejected from the fixing section by the rotation of the eject pulley and roller.

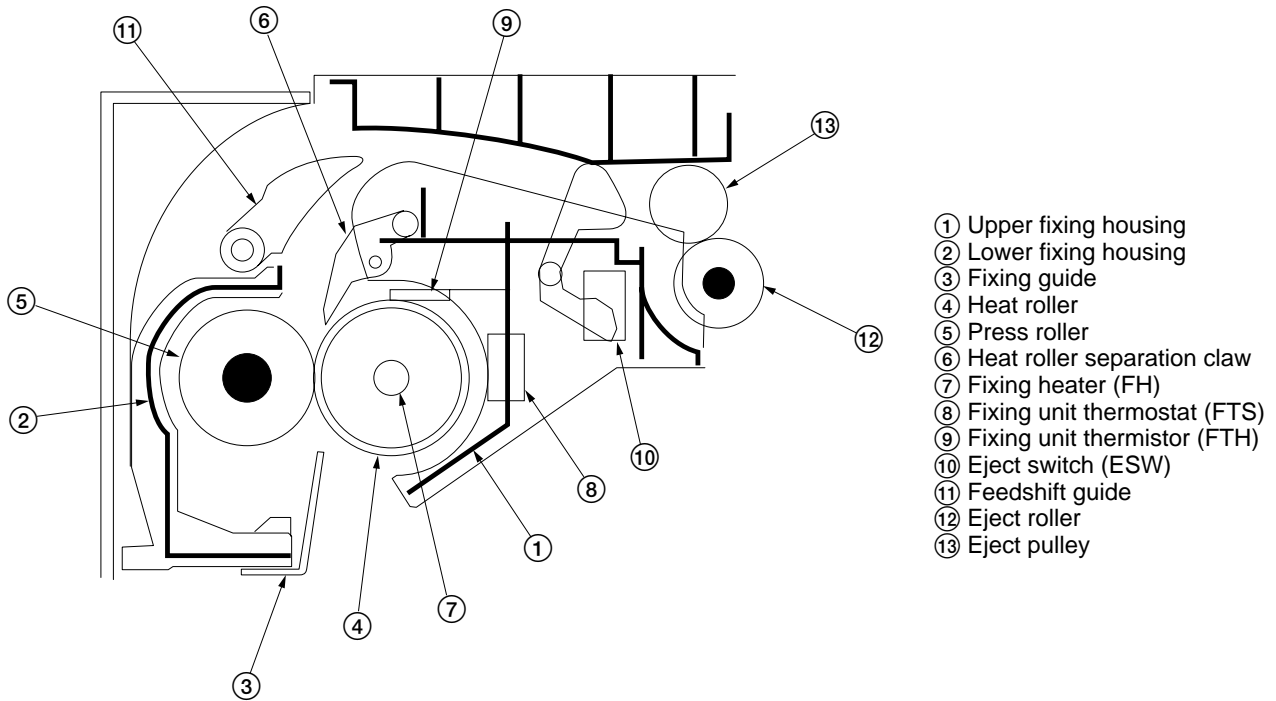

Figure 2-1-24 Fixing section

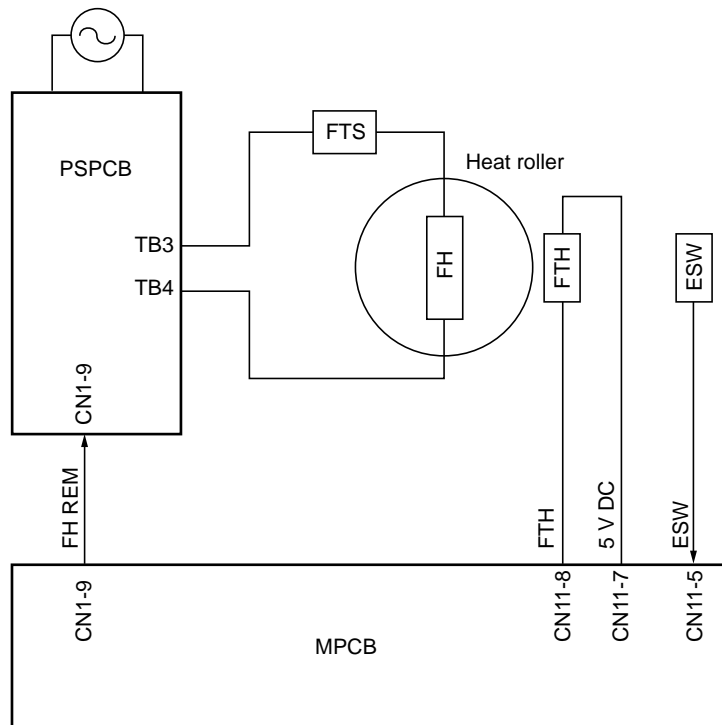
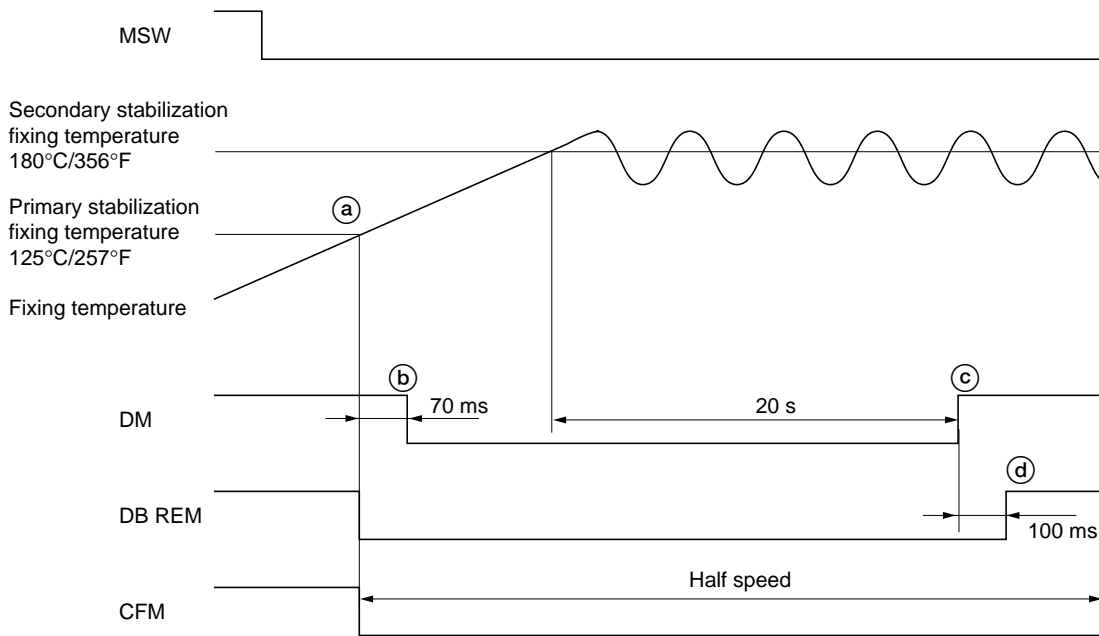

Figure 2-1-25 Fixing section block diagram



Timing chart 2-1-7 Operation of fixing section

- Ⓐ: When the fixing temperature reaches 125°C/257°F after the main switch (MSW) is turned on, the copier enters primary stabilization. The developing bias (DB REM) turns on and the cooling fan motor (CFM) rotates at half speed.
- Ⓑ: 70 ms after the primary stabilization starts, the drive motor (DM) turns on.
- Ⓒ: When the fixing temperature reaches 180°C/356°F, the copier enters secondary stabilization and the drive motor (DM) turns off 20 s later.
- Ⓓ: 100 ms after the drive motor (DM) turns off, the developing bias (DB REM) turns off.

• Fixing control temperature correction

During copying, the fixing control temperature is corrected based on the size of paper used and ambient temperature.

Ambient temperature Size of paper	10°C/50°F	20°C/68°F	30°C/86°F
A4R/8 ¹ / ₂ " × 11"R	185°C/365°F	180°C/356°F	175°C/347°F
B5	175°C/347°F	170°C/338°F	165°C/329°F
A5R/5 ¹ / ₂ " × 8 ¹ / ₂ "R	165°C/329°F	160°C/320°F	155°C/311°F

2-2-1 Electrical parts layout

(1) PCBs

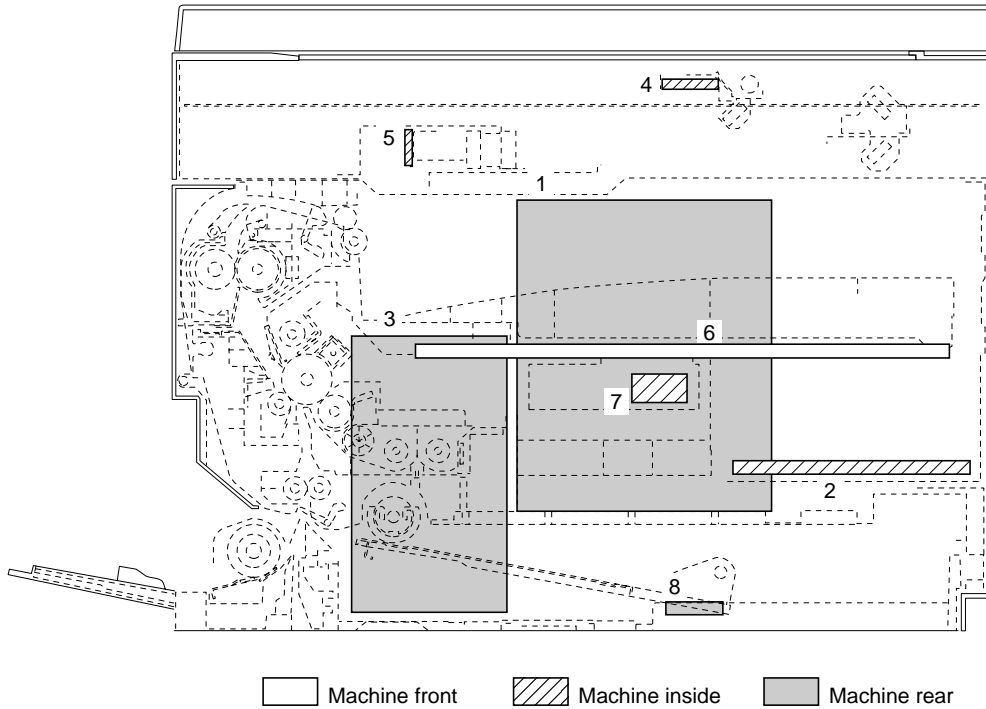

Figure 2-2-1 PCBs

- 1. Main PCB (MPCB) Controls the other PCBs and electrical components.
- 2. Power source PCB (PSPCB) Generates 24 V DC, 12 V DC and 5 V DC; controls the fixing heater.
- 3. High-voltage transformer PCB (HVTPCB) ... Main charging. Generates developing bias and high voltages for transfer.
- 4. Inverter PCB (INPCB) Controls the exposure lamp.
- 5. CCD PCB (CCDPCB) Reads the image off originals.
- 6. Operation unit PCB (OPCB) Consists of the operation keys and display LEDs.
- 7. Laser diode PCB (LDPCB) Generates and controls the laser light.
- 8. Humidity sensor PCB (HUMSPCB) Detects absolute humidity.

(2) Switches and sensors

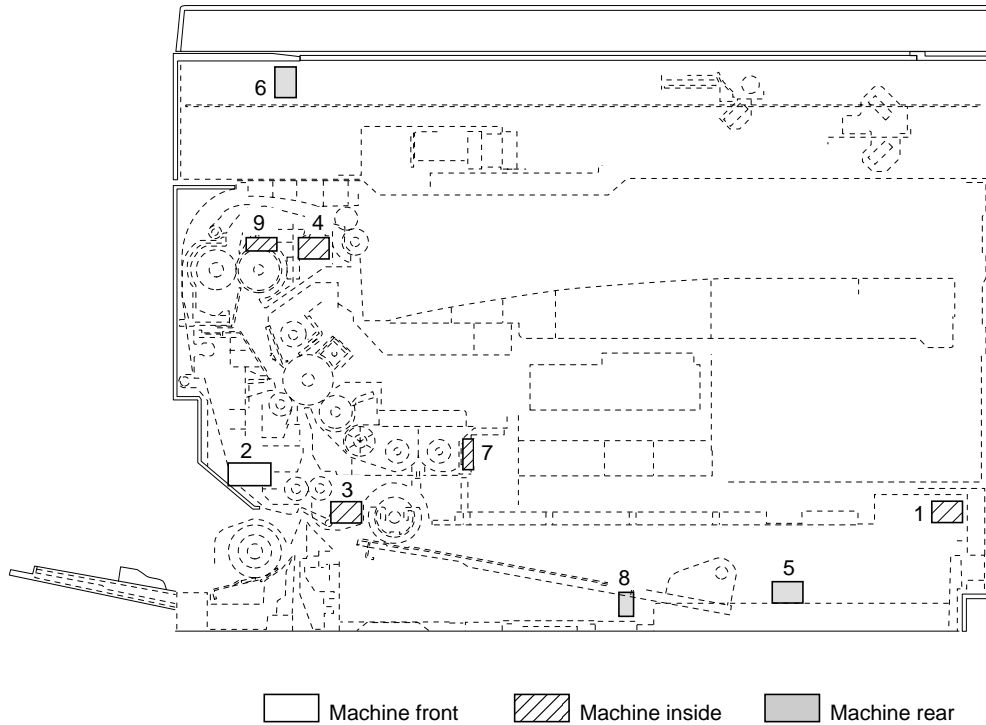

Figure 2-2-2 Switches and sensors

- 1. Main switch (MSW) Turns the AC power on and off.
- 2. Safety switch (SSW) Breaks the safety circuit when the front cover or paper conveying cover is opened; resets paper jam detection.
- 3. Registration switch (RSW) Controls the secondary paper feed start timing and detects the presence of paper in the drawer.
- 4. Eject switch (ESW) Detects a paper misfeed in the fixing section.
- 5. Drawer detection switch (DDSW) Detects the insertion of the drawer.
- 6. Scanner home position switch (SHPSW) Detects the scanner in the home position.
- 7. Toner sensor (TNS) Detects the toner density in the developing section.
- 8. Humidity sensor (HUMSENS) Detects absolute humidity.
- 9. Fixing unit thermistor (FTH) Detects the heat roller temperature.

(3) Motors

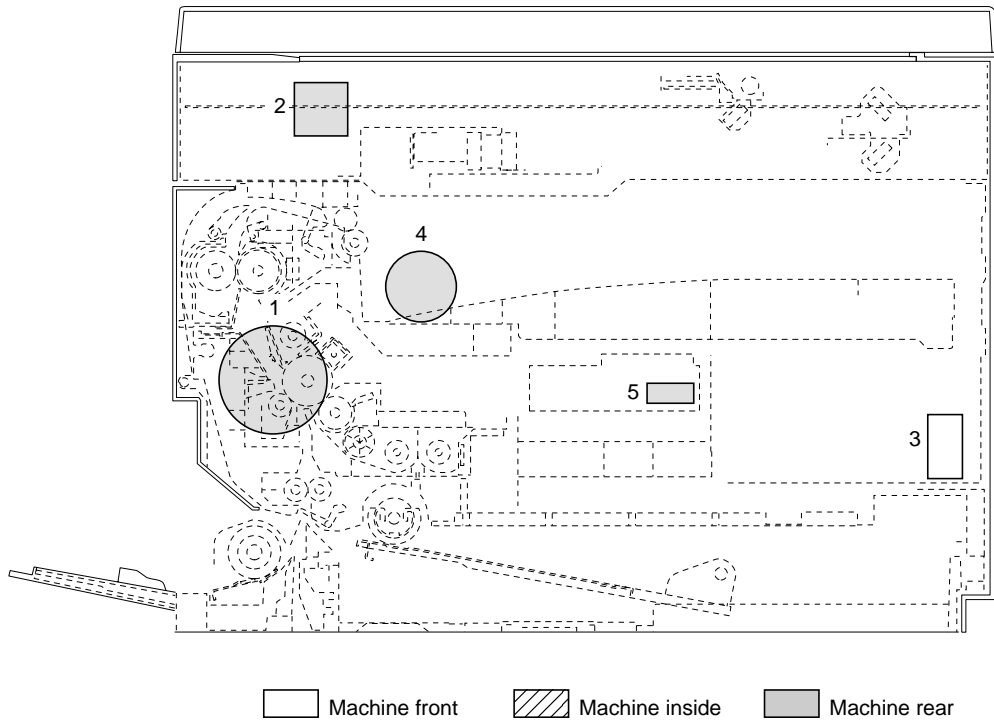

Figure 2-2-3 Motors

- 1. Drive motor (DM) Drives the machine.
- 2. Scanner motor (SM) Drives the optical system.
- 3. Toner feed motor (TFM) Replenishes toner.
- 4. Cooling fan motor (CFM) Cools the machine interior.
- 5. Polygon motor (PM) Drives the polygon mirror.

(4) Other electrical components

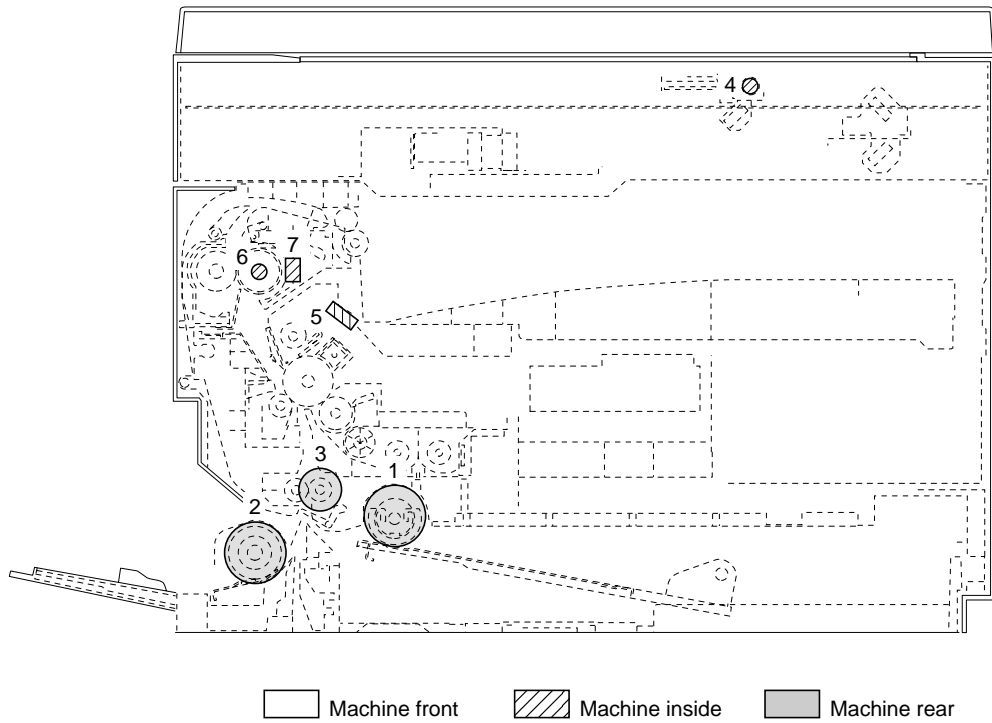

Figure 2-2-4 Other electrical components

- 1. Paper feed clutch (PFCL) Primary paper feed from the drawer.
- 2. Bypass paper feed clutch (BYPPFCL) Primary paper feed from the bypass tray.
- 3. Registration clutch (RCL) Secondary paper feed.
- 4. Exposure lamp (EL) Exposes originals.
- 5. Cleaning lamp (CL) Removes residual charge from the drum surface.
- 6. Fixing heater (FH) Heats the heat roller.
- 7. Fixing unit thermostat (FTS) Prevents overheating in the fixing section.

2-3-1 Power source PCB

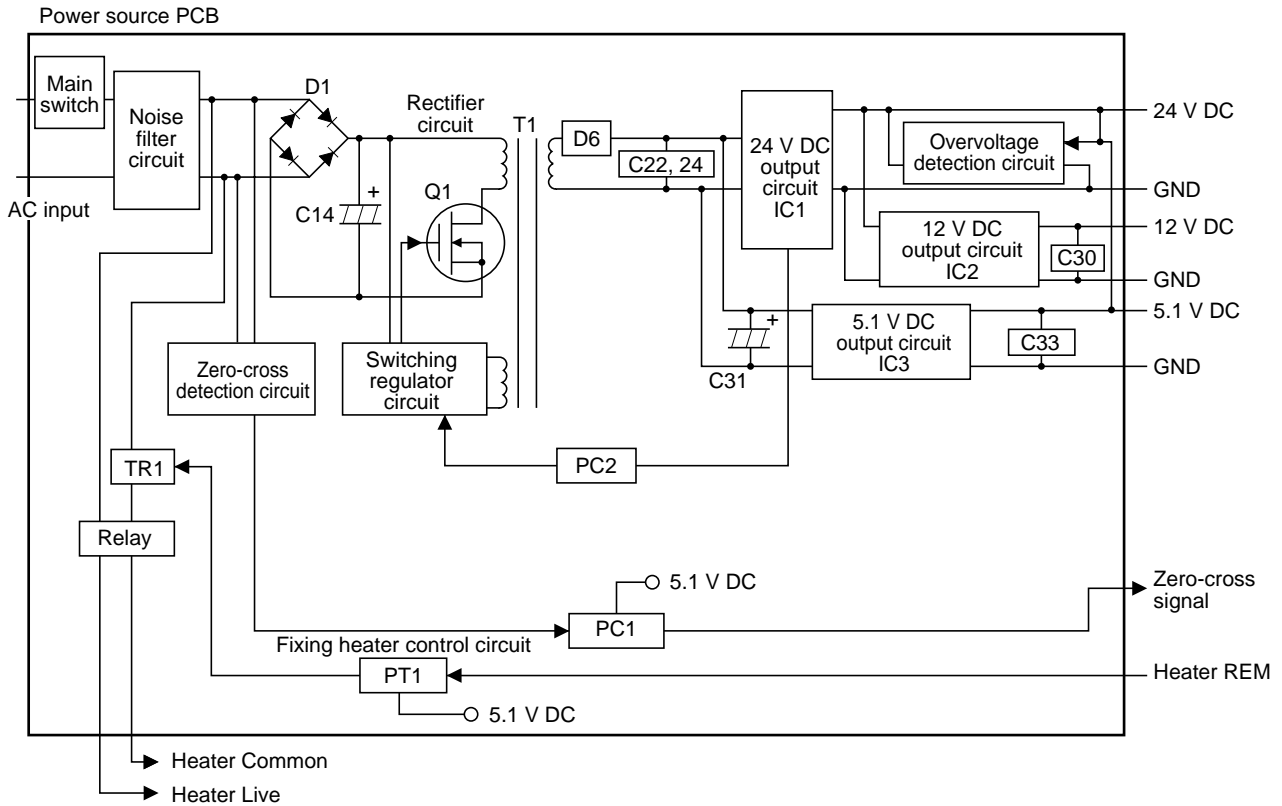

Figure 2-3-1 Power source PCB block diagram

The power source PCB (PSPCB) is a switching regulator that converts an AC input to generate 24 V DC, 5.1 V DC and 12 V DC. It includes a noise filter circuit, a rectifier circuit, a switching regulator circuit, a 24 V DC output circuit, a 5 V DC output circuit, a 12 V DC output circuit, a fixing heater control circuit and a zero-cross detection circuit.

The noise filter circuit consists mainly of a line filter and capacitors. It reduces external noise from the AC input and prevents switching noise generated by the power source PCB from leaving the machine.

The rectifier circuit full-wave rectifies the AC input that has passed through the noise filter circuit using the diode bridge D1. The smoothing capacitor C14 smoothes out the pulsed current from the diode bridge.

The switching control circuit turns on/off the power MOSFET Q1 with the voltage induced in the controlling coil of the transformer T1 to switch the current induced in the primary coil of the transformer T1.

The 24 V DC output circuit smoothes the current induced in the secondary coil of the transformer T1 via diode D6 and smoothing capacitors C22 and C24, and outputs a stable 24 V DC by the function of the shunt regulator IC1. The output status of the 24 V DC is fed back to the switching control circuit via the photo-coupler PC2. Based on the feedback, the switching control circuit changes the duty cycle of the pulse that turns power MOSFET Q1 on/off in order to adjust the 24 V DC.

The 5.1 V DC output circuit consists of a step-down chopper circuit that uses IC4 as the control IC. It outputs a stable 5.1 V DC.

The 12 V DC output circuit converts the 24 V DC from the 24 V DC output circuit to a stable 12 V DC by means of the 4-pin regulator IC2.

The zero-cross detection circuit determines the timing at which the fixing heater turns on and sends zero-cross signals to the main PCB (MPCB).

The fixing heater control circuit is controlled by the fixing heater on signal from the main PCB (MPCB). The phototriac PT1 turns on when the fixing heater on signal goes low. When the phototriac PT1 is turned on, current flows through the triac TR1 to turn the fixing heaters on.

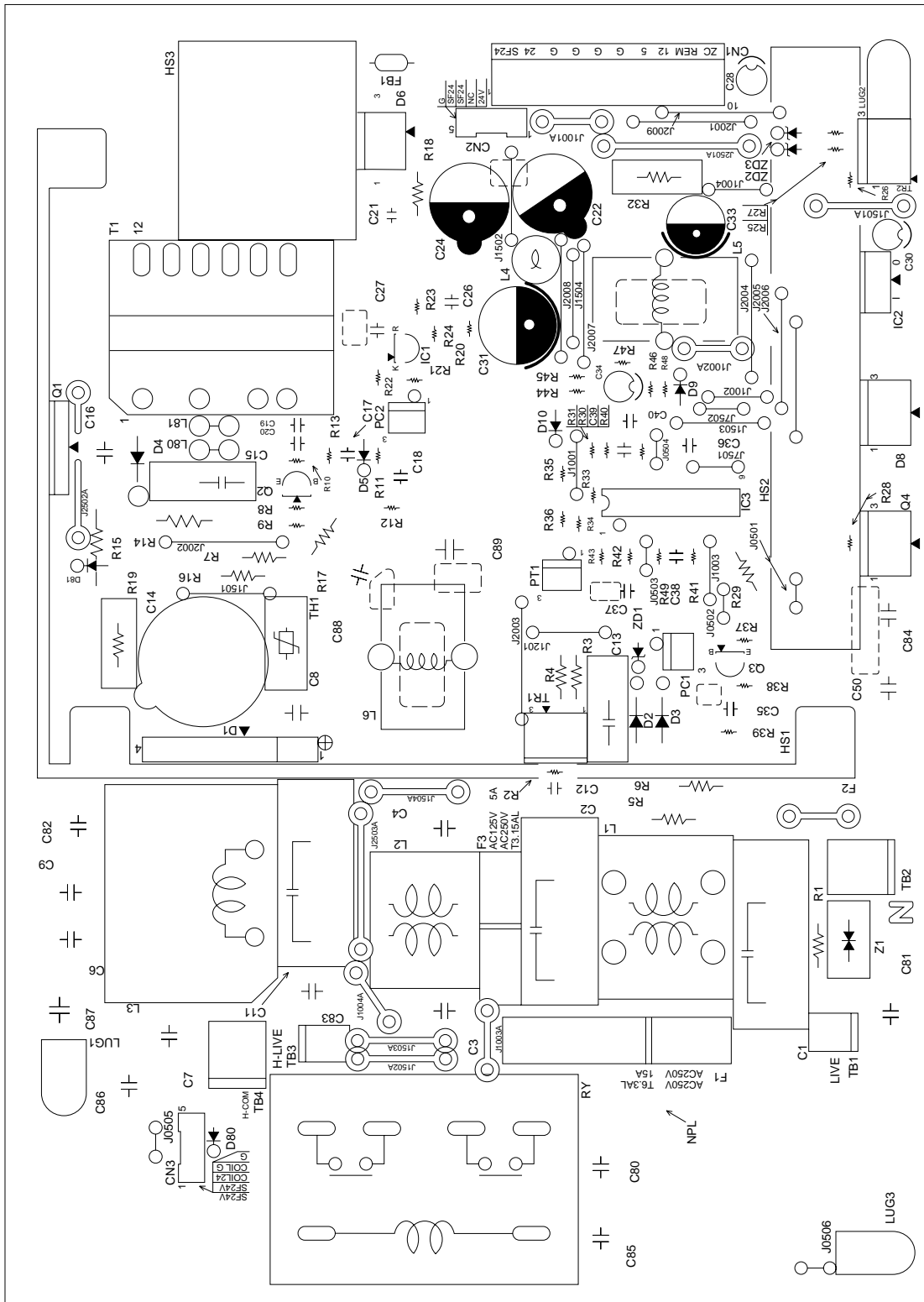

Figure 2-3-2 Power source PCB silk-screen diagram

Terminals (CN)		Voltage	Remarks
TB-1	TB-2	120 V AC	120 V AC supply, input
TB-1	TB-2	220-240 V AC	220-240 V AC supply, input
TB-3	TB-4	120 V AC	120 V AC supply for FH, output
TB-3	TB-4	220-240 V AC	220-240 V AC supply for FH, output
1-1	1-3	24 V DC SF	24 V DC supply for MPCB, output (when SSW is on)
1-2	1-4	24 V DC	24 V DC supply for MPCB, output
1-7	1-5	5.1 V DC	5.1 V DC supply for MPCB, output
1-8	1-6	12 V DC	12 V DC supply for MPCB, output
1-9	1-5	0/5 V DC	FH on/off, input
1-10	1-5	0/5 V DC (pulse)	Zero-cross signal, output
2-1	2-5	24 V DC	24 V DC supply for SSW, output
2-3	2-5	24/0 V DC	SSW on/off, input

2-3-2 Main PCB

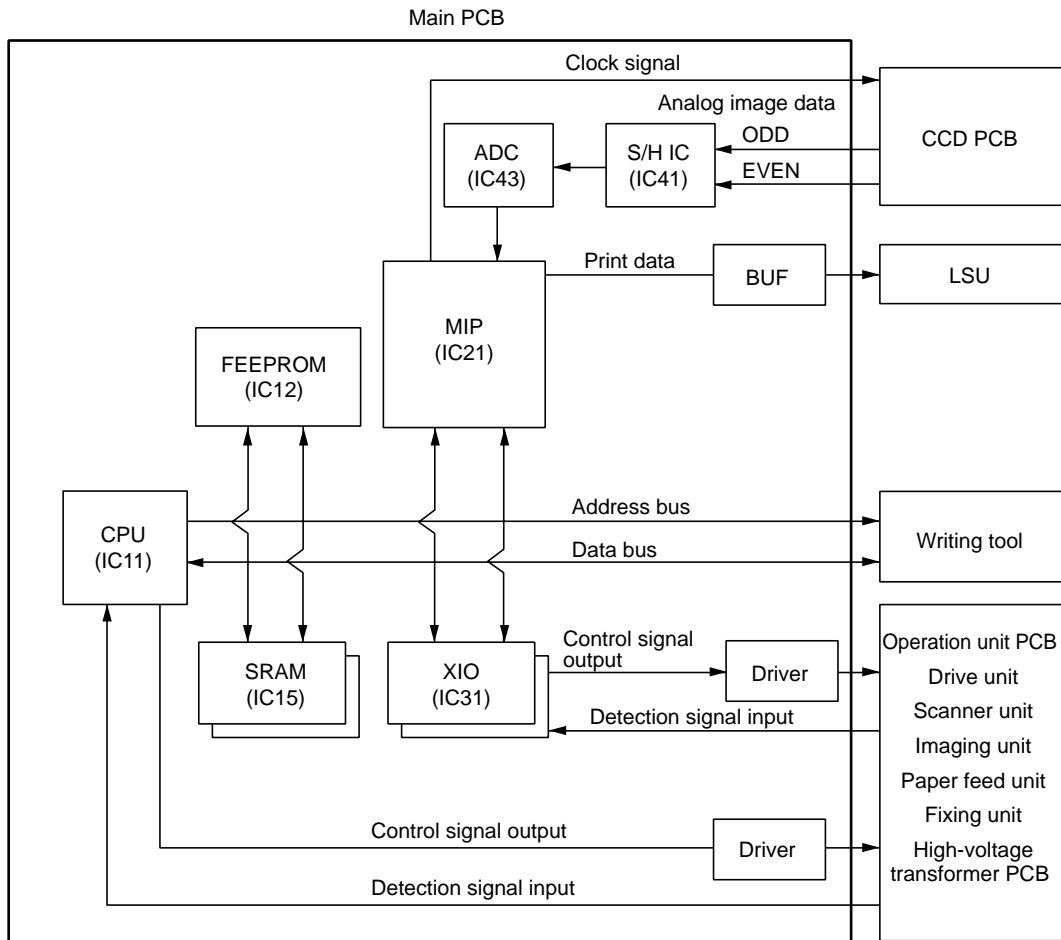

Figure 2-3-3 Main PCB block diagram

The main PCB (MPCB) consists mainly of CPU IC11. It controls the image processing system and engine drive system. The CPU IC11 operates on an 8-bit bus. It uses the SRAM IC15 for work memory and backup memory. In accordance with the control program in FEEPROM IC12, the CPU IC11 communicates with the printer controller via the serial communication function in the CPU. The CPU IC11 also controls the CCD PCB (CCDPCB), which is for image input control, and the LSU, which is for image output control, via the image processing ASIC MIP IC21, and drives the operation section and machine, conveys paper and detects abnormalities via XIO IC31.

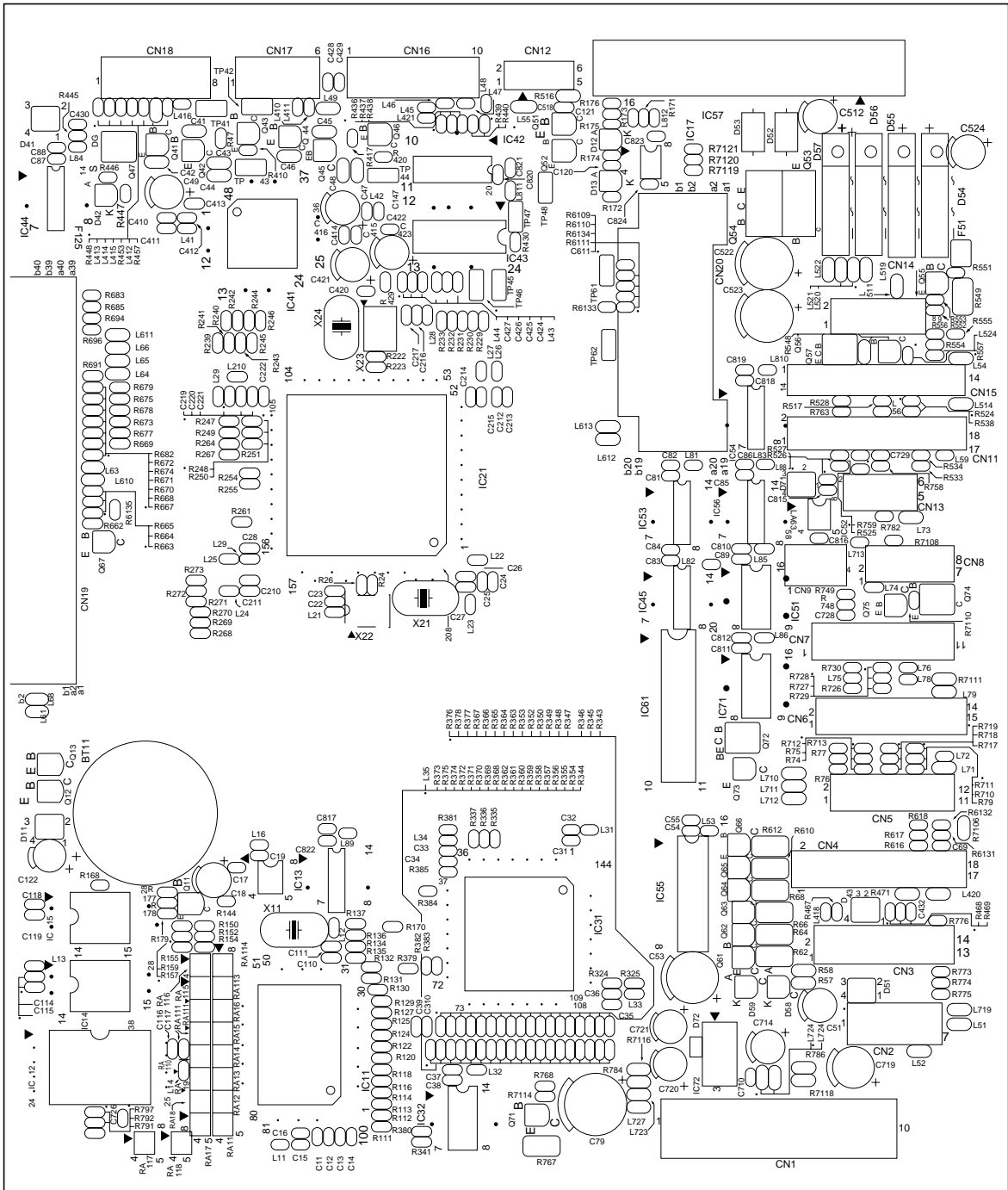

Figure 2-3-4 Main PCB silk-screen diagram

Terminals (CN)		Voltage	Remarks
1-1	1-3	24 V DC SF	24 V DC supply from PSPCB, input (when SSW is on)
1-2	1-4	24 V DC	24 V DC supply from PSPCB, input
1-7	1-5	5.1 V DC	5.1 V DC supply from PSPCB, input
1-8	1-6	12 V DC	12 V DC supply from PSPCB, input
1-9	1-5	0/5 V DC	FH on/off, output
1-10	1-5	0/5 V DC (pulse)	Zero-cross signal, input
2-2	1-6	0 - 14 V DC	TNS control voltage, output
2-3	3-2	24 V DC	24 V DC supply for TNS, output
2-4	1-6	0 - 5 V DC	TNS detection voltage, input
2-6	3-2	24/0 V DC	TFM drive control signal (+), output
2-7	3-2	0/24 V DC	TFM drive control signal (-), output
3-1	3-2	24 V DC SF	24 V DC supply for PM, output
3-3	3-2	24/0 V DC	PM on/off, output
3-4	3-10	0/5 V DC	MSYNC signal, output
3-5	3-10	0/5 V DC (pulse)	PM drive clock pulse, output
3-6	3-2	24/0 V DC	CL on/off, output
3-7	3-2	24 V DC	24 V DC supply for CL, output
3-8	3-2	24/0 V DC	MSW on/off, input
3-9	3-2	24 V DC	24 V DC supply for MSW, output
3-11	3-10	0/5 V DC	DDSW on/off, input
3-13	3-12	0/5 V DC	RSW on/off, input
3-14	3-12	5 V DC	5 V DC supply for RSW, output
4-1	4-18	0/5 V DC	OPCB SEG0 signal, output
4-2	4-18	0/5 V DC	OPCB SEG1 signal, output
4-3	4-18	0/5 V DC	OPCB SEG2 signal, output
4-4	4-18	0/5 V DC	OPCB SEG3 signal, output
4-5	4-18	0/5 V DC	OPCB SEG4 signal, output
4-6	4-18	0/5 V DC	OPCB SEG5 signal, output
4-7	4-18	0/5 V DC (pulse)	OPCB DIG0 signal, output
4-8	4-18	0/5 V DC (pulse)	OPCB DIG1 signal, output
4-9	4-18	0/5 V DC (pulse)	OPCB DIG2 signal, output
4-10	4-18	0/5 V DC (pulse)	OPCB DIG3 signal, output
4-11	4-18	0/5 V DC (pulse)	OPCB DIG4 signal, output
4-12	4-18	0/5 V DC (pulse)	OPCB DIG5 signal, output
4-13	4-18	0/5 V DC (pulse)	OPCB DIG6 signal, output
4-14	4-18	0/5 V DC (pulse)	OPCB DIG7 signal, output
4-15	4-18	0/5 V DC	OPCB KEY0 signal, input
4-16	4-18	0/5 V DC	OPCB KEY1 signal, input
6-1	6-14	24/0 V DC	BYPPFCL on/off, output
6-2	6-14	24 V DC	24 V DC supply for BYPPFCL, output
6-3	6-14	24 V DC	24 V DC supply for PFCL, output
6-4	6-14	24/0 V DC	PFCL on/off, output
6-5	6-14	24 V DC	24 V DC supply for RCL, output
6-6	6-14	24/0 V DC	RCL on/off, output
6-7	1-6	0 - 5 V DC	Transfer charging control voltage, output
6-8	6-14	0/5 V DC	Transfer charging on/off, output
6-9	1-6	0 - 5 V DC	Developing bias control voltage, output
6-10	6-14	0/5 V DC	Developing bias on/off, output
6-11	6-14	0/5 V DC	Main charging ALM signal, input
6-12	1-6	0 - 5 V DC	GRID control voltage, output
6-13	6-14	0/5 V DC	Main charging on/off, output
6-15	6-14	24 V DC SF	24 V DC supply for HVTPCB, output
9-1	1-6	-	ETTH detection voltage, input
9-3	1-6	0 - 5 V DC	HUMSENS detection voltage, input
9-4	9-2	5 V DC	5 V DC supply for HUMSPCB, output
11-2	11-1	0/5 V DC	SHPSW on/off, input

Terminals (CN)		Voltage	Remarks
11-3	11-1	5 V DC	5 V DC supply for HUMSPCB, output
11-5	11-4	0/5 V DC	ESW on/off, input
11-6	11-4	5 V DC	5 V DC supply for ESW, output
11-7	11-4	5 V DC	5 V DC supply for FTH, output
11-8	1-6	0 - 5 V DC	FTH detection voltage, input
12-1	12-5	0/24 V DC	EL on/off, output
12-2	12-5	0/24 V DC	EL on/off, output
12-3	12-5	24 V DC	24 V DC supply for INPCB, output
12-4	12-5	24 V DC	24 V DC supply for INPCB, output
13-1	13-2	24 V DC SF	24 V DC supply for DM, output
13-4	13-3	0/5 V DC (pulse)	DM drive clock pulse, output
13-5	13-2	0/24 V DC	DM on/off, output
15-1	13-2	0/24 V DC (pulse)	SM coil energization pulse, output (_A)
15-2	13-2	24 V DC	24 V DC supply for SM, output
15-3	13-2	0/24 V DC (pulse)	SM coil energization pulse, output (A)
15-4	13-2	0/24 V DC (pulse)	SM coil energization pulse, output (B)
15-5	13-2	24 V DC	24 V DC supply for SM, output
15-6	13-2	0/24 V DC (pulse)	SM coil energization pulse, output (_B)
15-12	13-2	0/24 V DC	CFM on/off, output
15-13	13-2	0/24 V DC	CFM half speed/full speed, output
15-14	13-2	24 V DC	24 V DC supply for CFM, output
16-1	16-2	0/5 V DC (pulse)	CCDPCB clock pulse, output
16-3	16-4	0/5 V DC (pulse)	CCDPCB clock pulse, output
16-5	16-6	0/5 V DC	CCDPCB RESET signal, output
16-7	16-8	0/5 V DC	CCDPCB CLP signal, output
16-9	16-10	0/5 V DC	CCDPCB SHIFT signal, output
17-1	17-2	–	CCDPCB image signal (ODD), input
17-3	17-4	–	CCDPCB image signal (EVEN), input
17-5	17-6	12 V DC	12 V DC supply for CCDPCB, output
18-1	18-2	0/5 V DC	LDPCB BD signal, input
18-3	18-2	5 V DC SF	5 V DC supply for LDPCB, output
18-5	18-2	0/5 V DC	LDPCB ENABLE signal, input
18-6	18-2	0/5 V DC	LDPCB VIDEO signal, input
18-7	18-2	0/5 V DC	LDPCB ADJUST signal, input

2-3-3 Operation PCB

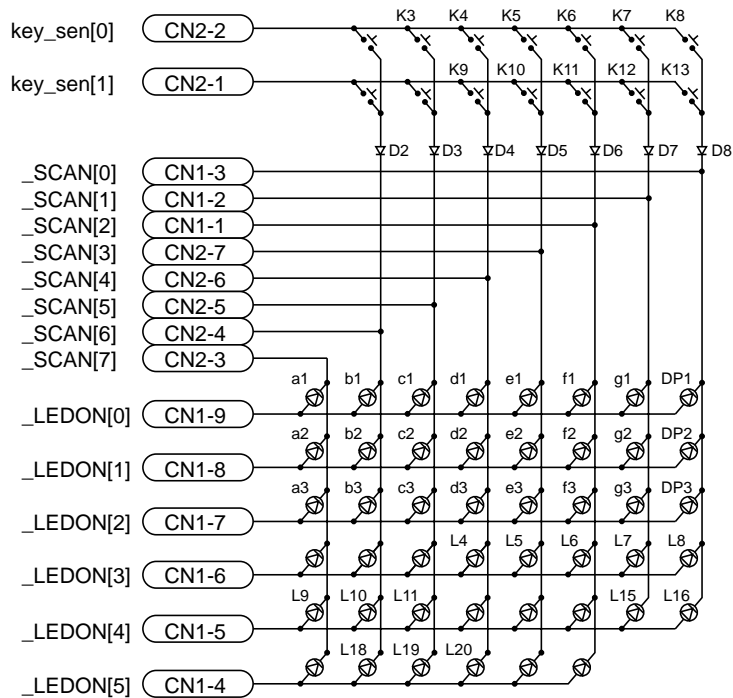

Figure 2-3-5 Operation unit PCB block diagram

The operation unit PCB (OPCB) consists of key switches and LEDs. The lighting of LEDs is determined by scan signals (SCAN [0] to SCAN [7]) and LED lighting selection signals (LEDON [0] to LEDON [5]) from the main PCB (MPCB). The key switches operated are identified by the scan signals (SCAN [0] to SCAN [7]) and the return signals (key sen [0], [1]). As an example, to light "a1", the LED lighting selection signal (LEDON [0]) should be driven high in synchronization with a low level on the scan signal (SCAN [7]). LEDs can be lit dynamically by repeating such operations. As another example, if "K3" is pressed, the corresponding key switch is turned on feeding the low level of the scan signal (SCAN [5]) back to the main PCB (MPCB) via the return signal (key sen [0]). The main PCB (MPCB) locates the position where the line outputting the scan signal and the line inputting the return signal cross, and thereby determines which key switch was operated.

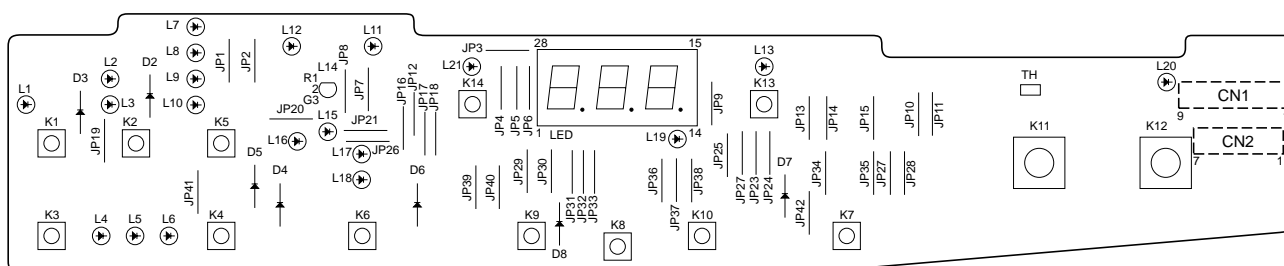

Figure 2-3-6 Operation unit PCB silk-screen diagram

Terminals (CN)		Voltage	Remarks
2-1	4-18	0/5 V DC	OPCB KEY1 signal, output
2-2	4-18	0/5 V DC	OPCB KEY0 signal, output
2-3	4-18	0/5 V DC (pulse)	OPCB DIG7 signal, input
2-4	4-18	0/5 V DC (pulse)	OPCB DIG6 signal, input
2-5	4-18	0/5 V DC (pulse)	OPCB DIG5 signal, input
2-6	4-18	0/5 V DC (pulse)	OPCB DIG4 signal, input
2-7	4-18	0/5 V DC (pulse)	OPCB DIG3 signal, input
1-1	4-18	0/5 V DC (pulse)	OPCB DIG2 signal, input
1-2	4-18	0/5 V DC (pulse)	OPCB DIG1 signal, input
1-3	4-18	0/5 V DC (pulse)	OPCB DIG0 signal, input
1-4	4-18	0/5 V DC	OPCB SEG5 signal, input
1-5	4-18	0/5 V DC	OPCB SEG4 signal, input
1-6	4-18	0/5 V DC	OPCB SEG3 signal, input
1-7	4-18	0/5 V DC	OPCB SEG2 signal, input
1-8	4-18	0/5 V DC	OPCB SEG1 signal, input
1-9	4-18	0/5 V DC	OPCB SEG0 signal, input

2-3-4 CCD PCB

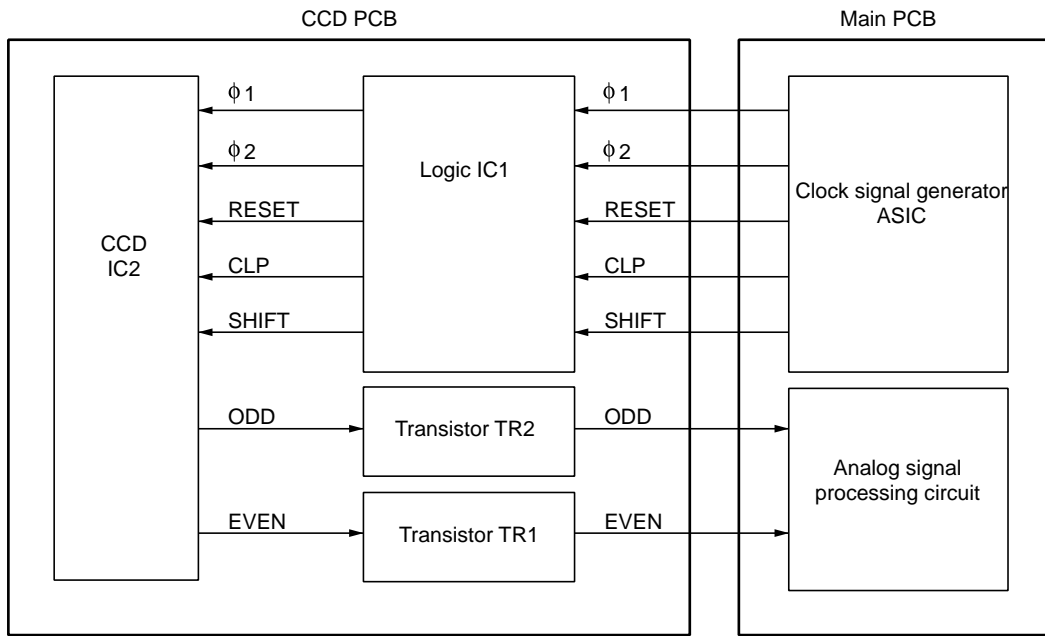

Figure 2-3-7 CCD PCB block diagram

The CCD PCB (CCDPCB) is equipped with a CCD sensor IC2 for original scanning.

The CCD sensor IC2 is controlled by the clock signals $\phi 1$, $\phi 2$, RESET, CLP and SHIFT for CCD drive from the main PCB (MPCB) via logic IC1.

Image signals are analog signals. Even- and odd-numbered pixels are output separately. These analog image signals are amplified by emitter followers in the transistors TR1 and TR2 and then transmitted to the analog signal processing circuit in the main PCB (MPCB).

Terminals (CN)		Voltage	Remarks
1-1	1-2	0/5 V DC (pulse)	CCDPCB clock pulse, input
1-3	1-4	0/5 V DC (pulse)	CCDPCB clock pulse, input
1-5	1-6	0/5 V DC	CCDPCB RESET signal, input
1-7	1-8	0/5 V DC	CCDPCB CLP signal, input
1-9	1-10	0/5 V DC	CCDPCB SHIFT signal, input
2-1	2-2	–	CCDPCB image signal (ODD), output
2-3	2-4	–	CCDPCB image signal (EVEN), output
2-5	2-6	12 V DC	12 V DC supply from MPCB, input

2-3-5 Laser diode PCB

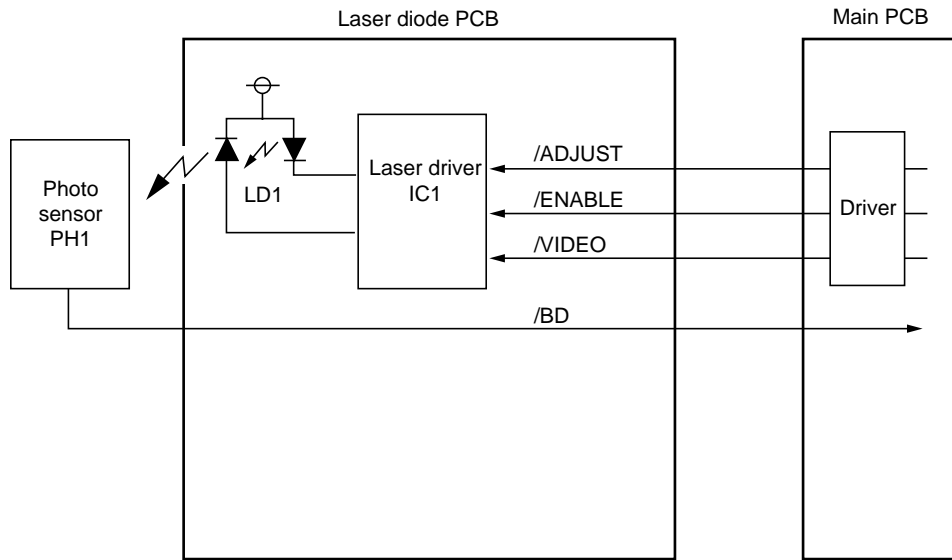
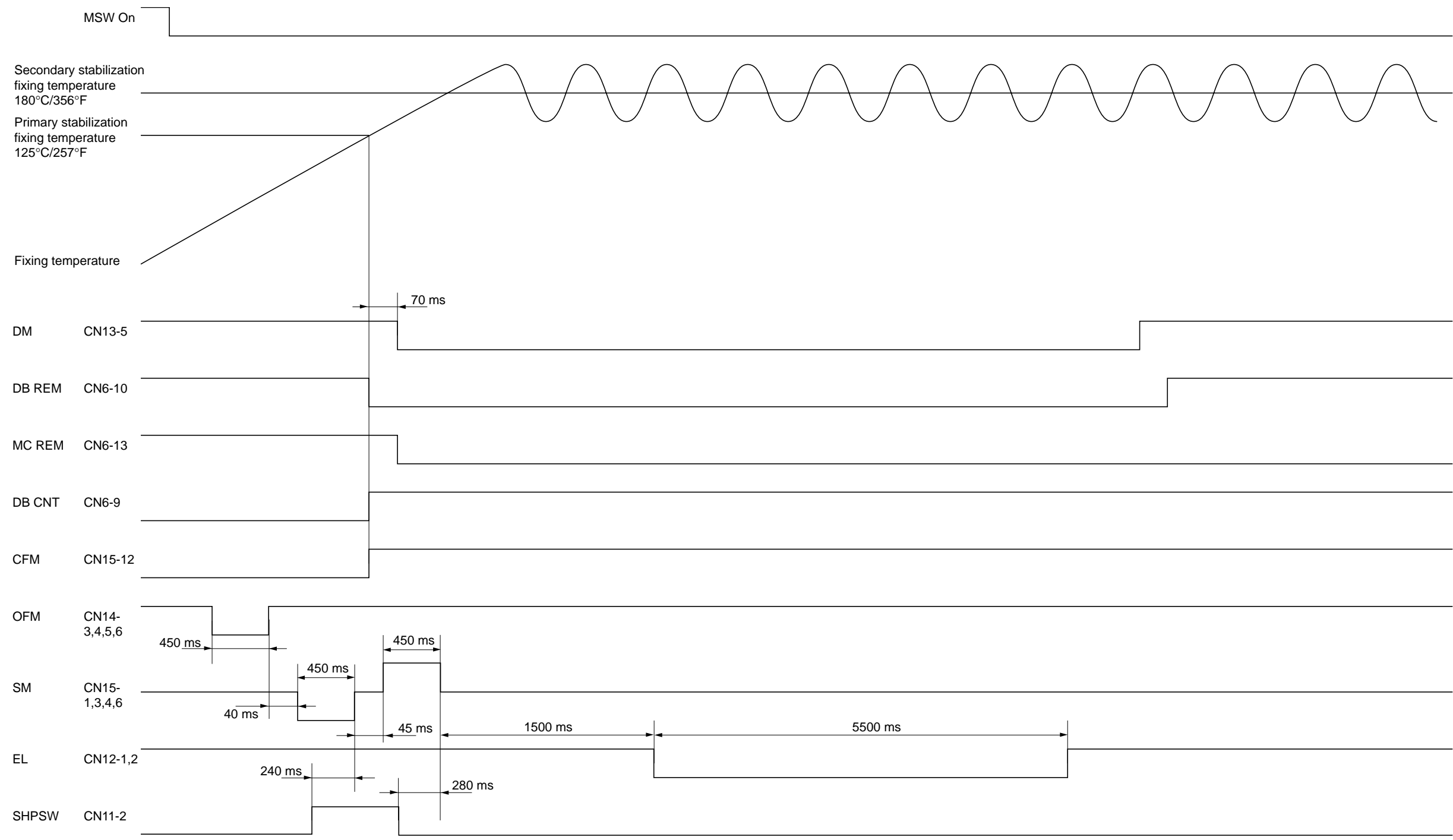

Figure 2-3-8 Laser diode PCB block diagram

The laser diode PCB (LDPCB) consists of the laser diode LD1 and laser driver IC1. The laser driver IC1 on the laser diode PCB (LDPCB) turns the laser diode LD1 on and off according to the image data received from the main PCB (MPCB). Upon detection of a laser beam from the laser diode LD1, the photo sensor PH1 outputs a horizontal sync signal (/BD) to the main PCB (MPCB). The laser diode PCB (LDPCB) adjusts the laser diode drive current (APC) for each line scanned outside the image area when /ADJUST is low to keep the laser beam output constant.

Terminals (CN)		Voltage	Remarks
1-1	1-2	0/5 V DC	LCDPCB BD signal, input
1-3	1-2	5 V DC SF	5 V DC supply for LCDPCB, input
1-5	1-2	0/5 V DC	LCDPCB ENABLE signal, input
1-6	1-2	0/5 V DC	LCDPCB VIDEO signal, input
1-7	1-2	0/5 V DC	LCDPCB ADJUST signal, output

Timing chart No. 1 From the main switch turned on to machine stabilization



Timing chart No. 2 Copying an A4R/8 1/2" x 11"R original onto a sheet of A4R/8 1/2" x 11"R copy paper from the drawer, magnification ratio 100%

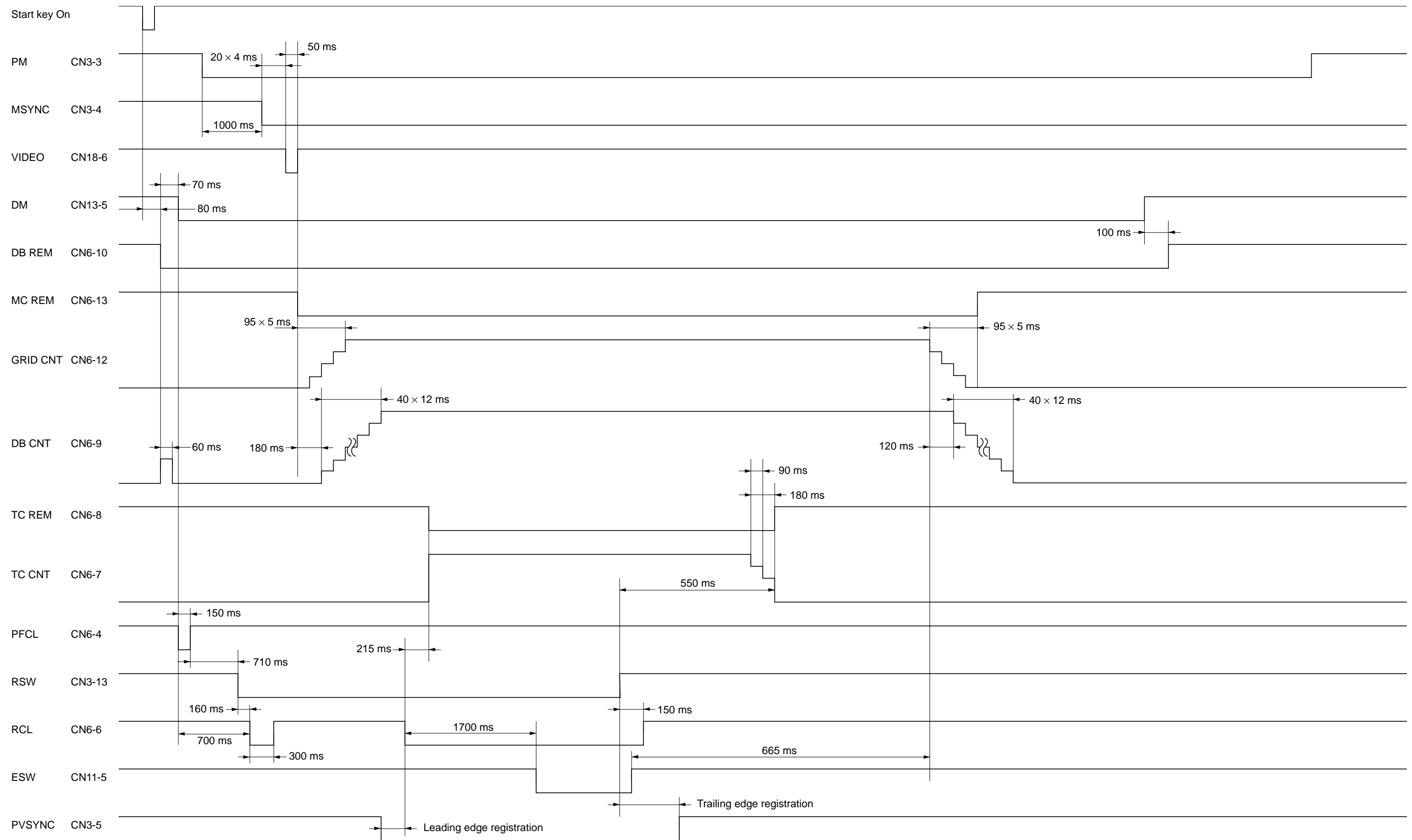

Timing chart No. 3 Continuous copying of an A4R/8 1/2" x 11"R original onto two sheets of A4R/8 1/2" x 11"R copy paper from the drawer, magnification ratio 100%

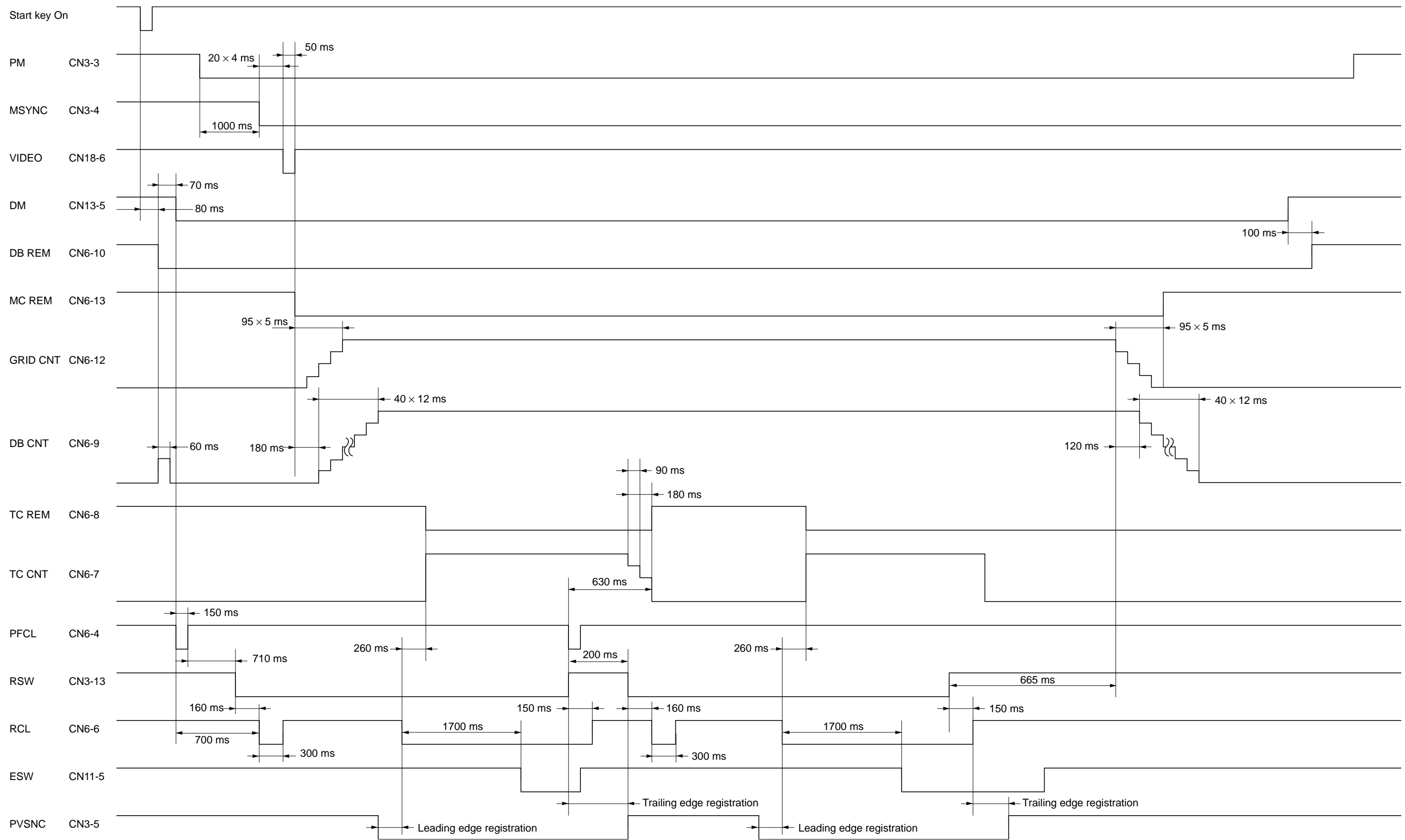

• Chart of image adjustment procedures

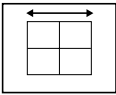
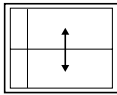
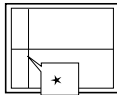
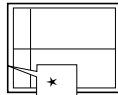
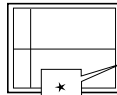
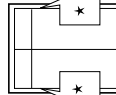
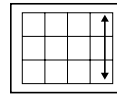
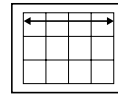
Adjusting order	Item	Image	Description	Maintenance mode		Original	Page	Remarks
				Item No.	Copy exposure indicator			
①	Adjusting the magnification in the auxiliary scanning direction (printing adjustment)		Drive motor speed adjustment	U053	Exp. 1 (lit)	U053 test pattern	1-4-9	
②	Adjusting the center line of the bypass table (printing adjustment)		Adjusting the LSU print start timing	U034	Exp. 1 (flashing)	U034 test pattern	1-6-9	
③	Adjusting the leading edge registration (printing adjustment)		Registration clutch turning on timing (secondary paper feed start timing)	U034	Exp. 1 (lit) Exp. 3 (lit)	U034 test pattern	1-6-8	Exp. 1: Paper feed from the drawer. Exp. 2: Paper feed from the bypass tray
④	Adjusting the leading edge margin (printing adjustment)		LSU illumination start timing	U402	Exp. 1 (lit)	U402 test pattern	1-6-10	
⑤	Adjusting the trailing edge margin (printing adjustment)		LSU illumination end timing	U402	Exp. 5 (lit)	U402 test pattern	1-6-10	
⑥	Adjusting the left and right margins (printing adjustment)		LSU illumination start/end timing	U402	Exp. 3 (lit)	U402 test pattern	1-6-10	
⑦	Adjusting magnification of the scanner in the main scanning direction (scanning adjustment)		Data processing	U065	Exp. 1 (lit)	Test chart	1-6-22	
⑧	Adjusting magnification of the scanner in the auxiliary scanning direction (scanning adjustment)		Original scanning speed	U065	Exp. 3 (lit)	Test chart	1-6-23	

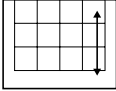
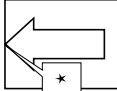
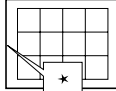
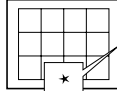
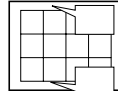
Adjusting order	Item	Image	Description	Maintenance mode		Original	Page	Remarks
				Item No.	Copy exposure indicator			
⑨	Adjusting the center line (scanning adjustment)		Adjusting the original scan data (image adjustment)	U067	—	Test chart	1-6-25	
⑩	Adjusting the leading edge registration (scanning adjustment)		Original scan start timing	U066	—	Test chart	1-6-24	
⑪	Adjusting the leading edge margin (scanning adjustment)		Adjusting the original scan data (image adjustment)	U403	Exp.3 (lit)	Test chart	1-6-26	
⑫	Adjusting the trailing edge margin (scanning adjustment)		Adjusting the original scan data (image adjustment)	U403	Exp.1 (flashing)	Test chart	1-6-26	
⑬	Adjusting the left and right margins (scanning adjustment)		Adjusting the original scan data (image adjustment)	U403	Left margin: Exp.3 (lit)	Test chart	1-6-26	

When maintenance item U092 (Adjusting the scanner automatically) is run using the specified original (P/N 2A168070), the following adjustments are automatically made:

- Adjusting the scanner center line (U067)
- Adjusting the scanner leading edge registration (U066)
- Adjusting the scanner magnification in the auxiliary scanning direction (U065)

• **Image quality**

Item	Specifications
100% magnification	$\pm 1.0\%$ or less
Enlargement/reduction	$\pm 1.5\%$ or less
Lateral squareness (copier mode)	± 1.5 mm/200 mm or less
Margins (copier mode)	A: 3.0 ± 2.5 mm (inch) $3.0 \pm_{-2.5}^{+3.5}$ mm (metric) B: 3.0 ± 2.5 mm C: 3.0 ± 2.5 mm (inch) $3.0 \pm_{-2.5}^{+3.5}$ mm (metric) D: 3.0 ± 2.5 mm
Margins (printer mode)	A: 6.0 ± 2.0 mm B: 6.0 ± 2.5 mm C: 6.0 ± 2.0 mm D: 6.0 ± 2.5 mm
Leading edge registration	Drawer: ± 2.5 mm or less Bypass: ± 2.5 mm or less
Skewed paper feed (left-right difference)	Drawer: 2.0 mm/200 mm or less Bypass: 2.0 mm/200 mm or less
Lateral image shifting	Drawer: ± 2.0 mm or less Bypass: ± 3.0 mm or less

Wiring diagram

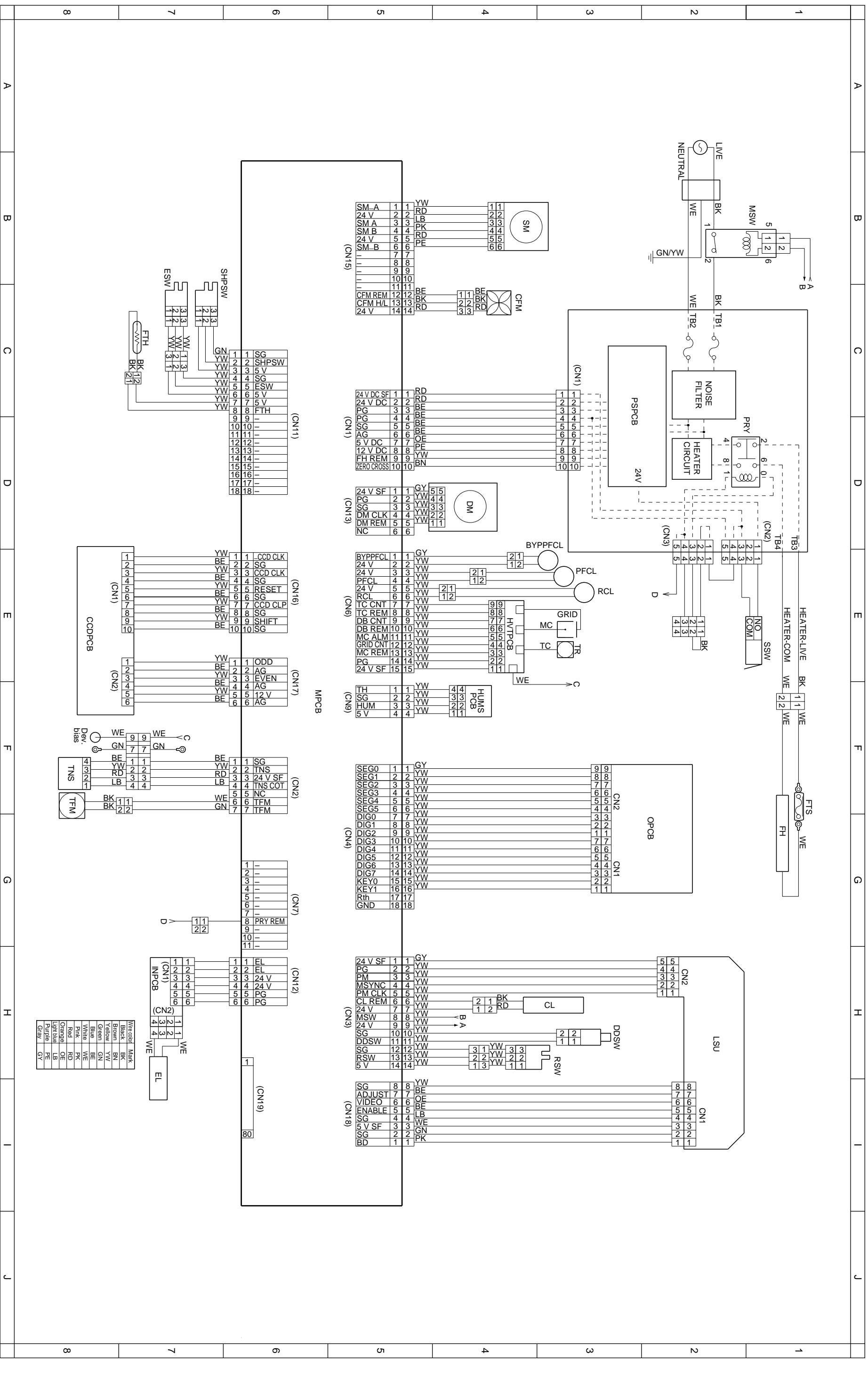

KYOCERA MITA EUROPE B.V.

Hoeksteen 40, 2132 MS Hoofddorp,
The Netherlands
Phone: (020) 6540000
Home page: <http://www.kyoceramita-europe.com>
Email: info@kyoceramita-europe.com

KYOCERA MITA NEDERLAND B.V.

Hoeksteen 40, 2132 MS Hoofddorp,
The Netherlands
Phone: (020) 5877200

KYOCERA MITA (UK) LIMITED

8 Beacontree Plaza
Gillette Way,
Reading RG2 0BS UK
Phone: (0118) 931 1500

KYOCERA MITA ITALIA S.P.A.

Via Marconi 8, 20041 Agrate Brianza
(Milano), Italy
Phone: (039) 65641

S.A. KYOCERA MITA BELGIUM N.V.

Hermesstraat 8A, 1930 Zaventem, Belgium
Phone: (02) 7209270

KYOCERA MITA FRANCE S.A.

Parc les Algorithmes
SAINT AUBIN
91194 GIF-SUR-YVETTE
France
Phone: (01) 69852600

KYOCERA MITA ESPAÑA S.A.

Edificio Mita, Avda. De Manacor Nº2,
Urb. Parque Rozas, Apartado de Correos 76,
28230 Las Rozas, Madrid, Spain
Phone: (91) 631-8392

KYOCERA MITA FINLAND OY

Kirvesmiehenkatu 4, 00810 Helsinki,
Finland
Phone: (09) 478-05200

KYOCERA MITA (SCHWEIZ) AG

Hölzliwisen, Industriestrasse 28,
8604 Volketswil, Switzerland
Phone: (01) 908 4949

KYOCERA MITA DEUTSCHLAND GMBH

Industriestrasse 17, D-61449 Steinbach/Ts,
Germany
Phone: (06171) 7005-0

KYOCERA MITA GMBH AUSTRIA

Eduard-Kittenberger-Gasse 95,
1230, Wien, Austria
Phone: (01) 86338-0

KYOCERA MITA SVENSKA AB

Siktgatan 2,
162 50 Vällingby, Sweden
Phone: (08) 4719999

KYOCERA MITA DANMARK A/S

Industrivej 11, DK-4632 Bjæverskov,
Denmark
Phone: 56871100

KYOCERA MITA PORTUGAL LDA.

CASCAISTOCK-Armazem nº8,
Rua das Fiskas, Alcoitão,
2765 Estoril, Portugal
Phone: (21) 4602221

KYOCERA MITA SOUTH AFRICA (PTY) LTD.

UNIT 3, "Kyalami Crescent,"
Kyalami Business Park,
1685 Midrand, South Africa
Phone: (11) 466-3290

KYOCERA MITA AMERICA, INC.

Headquarters:

225 Sand Road, P.O. Box 40008,
Fairfield, New Jersey 07004-0008,
U.S.A.
Phone: (973) 808-8444

KYOCERA MITA AUSTRALIA PTY. LTD.

Level 3, 6-10 Talavera Road, North Ryde,
N.S.W. 2113 Australia
Phone: (02) 9888-9999

KYOCERA MITA NEW ZEALAND LTD.

1-3 Parkhead Place,
Albany, Auckland,
New Zealand
Phone: (09) 415-4517

KYOCERA MITA (THAILAND) CORP., LTD.

9/209 Ratchada-Prachachem Road,
Bang Sue, Bangkok 10800, Thailand
Phone: (02) 586-0320

KYOCERA MITA SINGAPORE PTE LTD.

121 Genting Lane, 3rd Level,
Singapore 349572
Phone: (65) 7418733

KYOCERA MITA HONG KONG LIMITED

11/F., Mita Centre,
552-566, Castle Peak Road,
Tsuen Wan, New Territories,
Hong Kong
Phone: (852) 24232163

KYOCERA MITA CORPORATION

2-28, 1-chome, Tamatsukuri, Chuo-ku
Osaka 540-8585, Japan
Phone: (06) 6764-3555

©2001 KYOCERA MITA CORPORATION

 **KYOCERA** is a trademark of Kyocera Corporation

mita is a registered trademark of KYOCERA MITA CORPORATION

Printed in Holland